

REFRIGERATION MERCHANDISERS QUICK VIEW

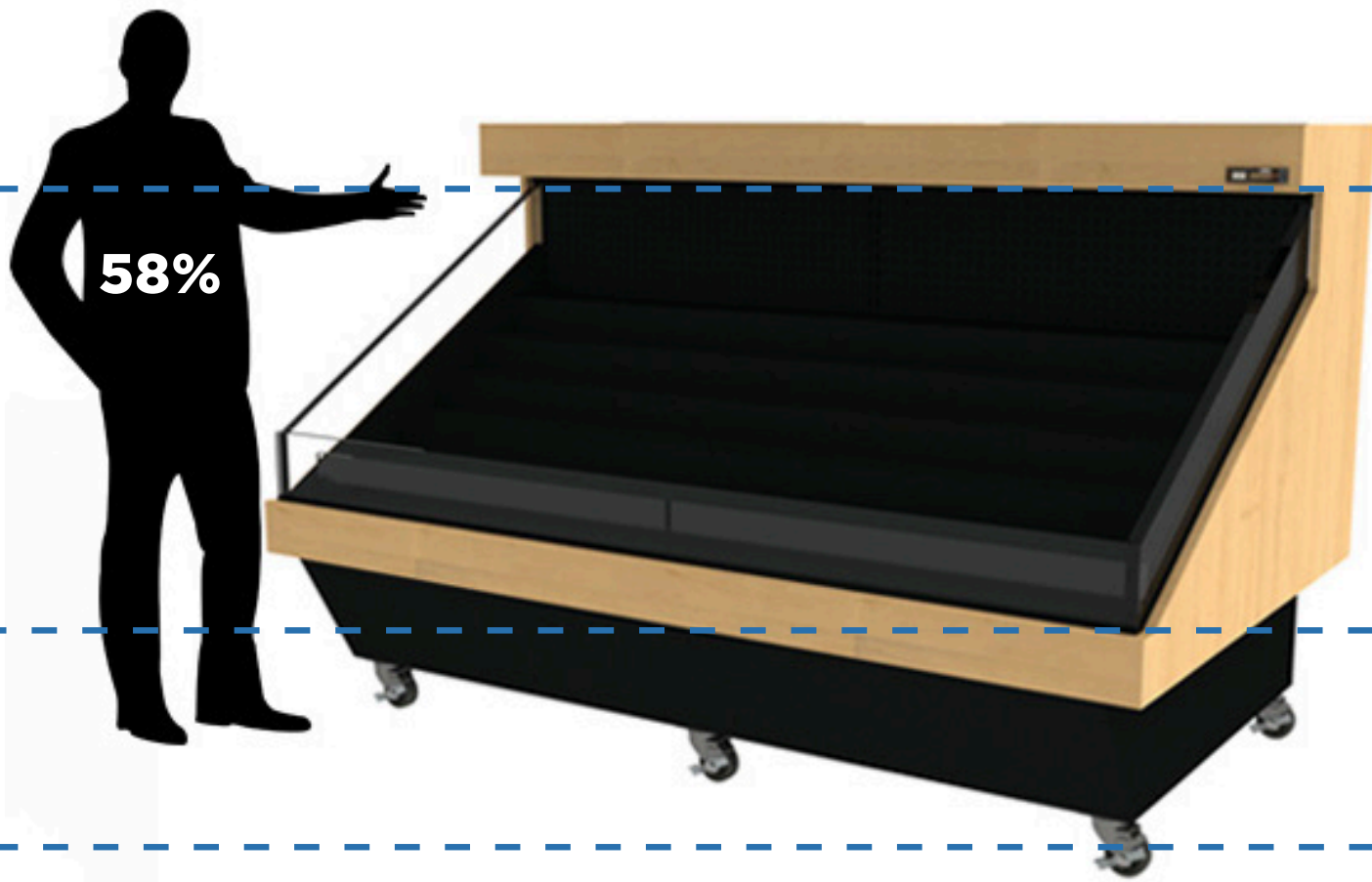

Compare our Standard Refrigeration Line to our New High-Visibility Line

Our new **High-Visibility Refrigeration Line** features more merchandising space for your product. Available in Remote and Self-Contained varieties, these merchandisers are designed to maintain product at Critical Temp, and can be modeled to match any store's décor.

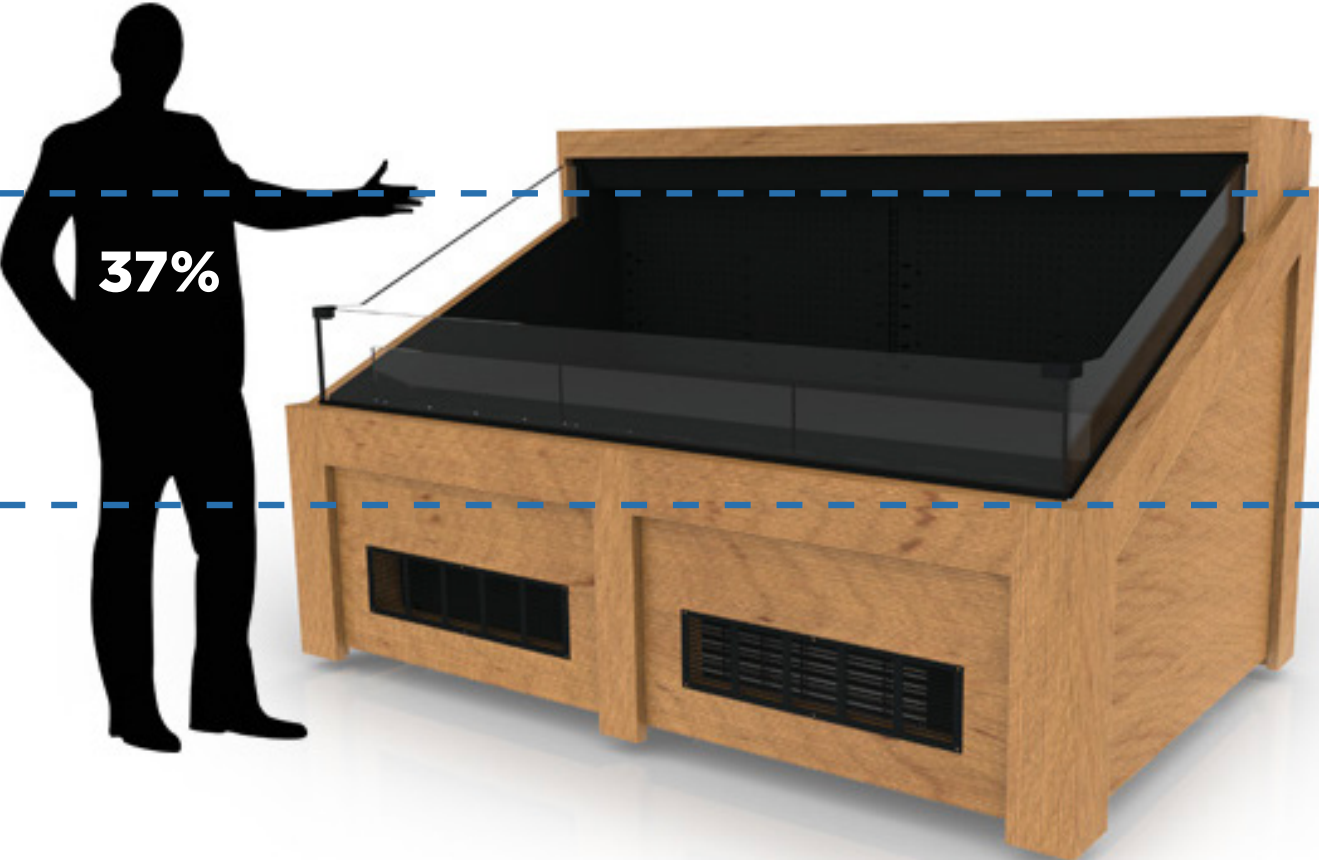

JSI can meet any of your merchandising needs with

our Standard and High Visibility Refrigeration lines

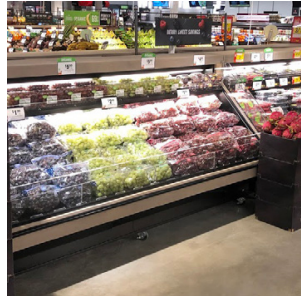
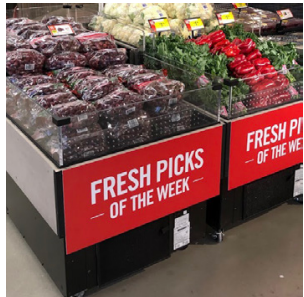

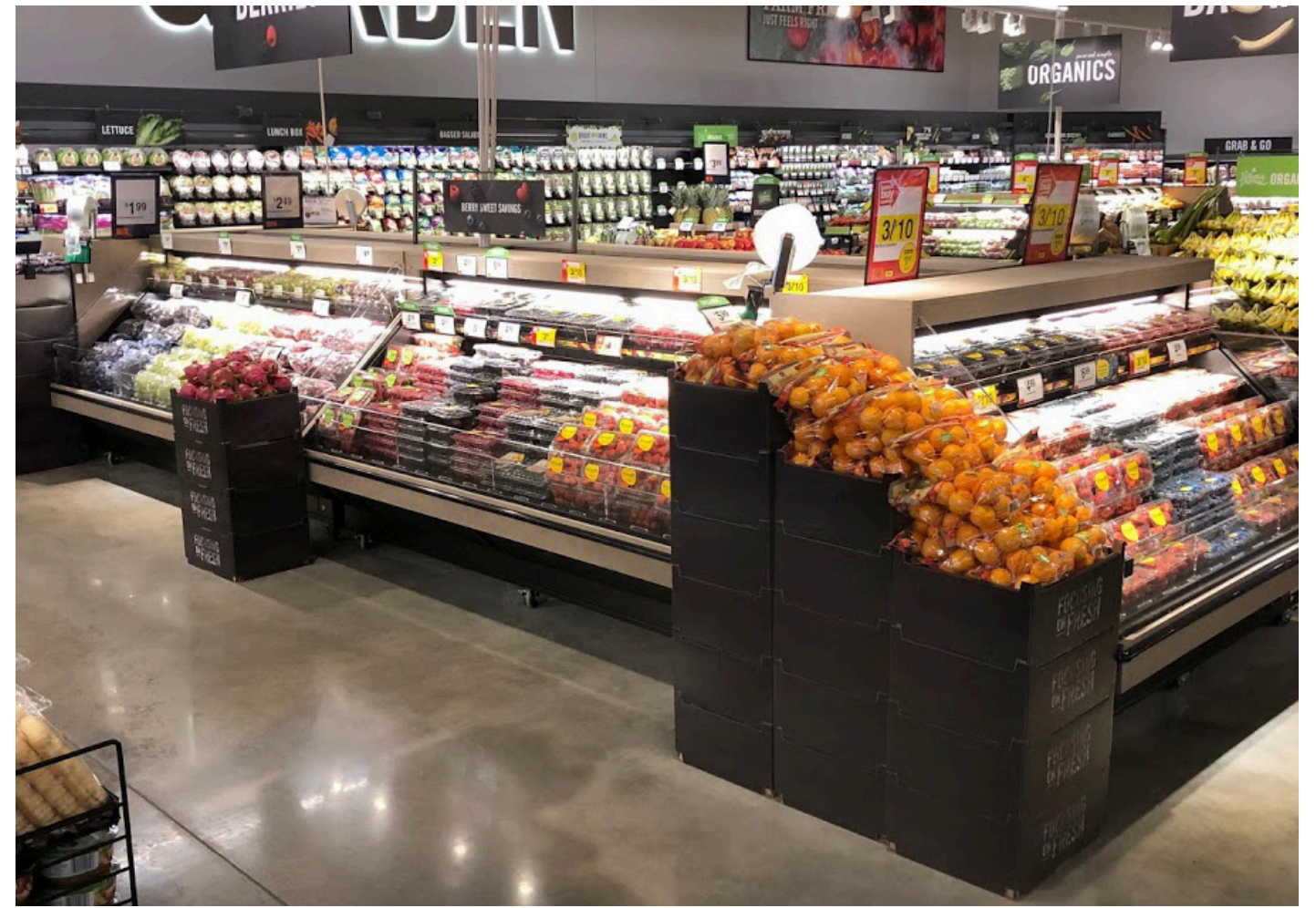





V-SERIES REMOTE REFRIGERATED CASES

V-SERIES REMOTE REFRIGERATED CASE

CRITICAL
TEMP



DESCRIPTION

Our V-Series refrigerated display cases bring added value to any program and are available in metal finishes.

BEST USED FOR

- Spot Merchandising
- Promotional displays
- Convenience stores
- Prepackaged meals

FEATURES

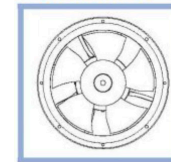

HIGH-EFFICIENCY MOTORS

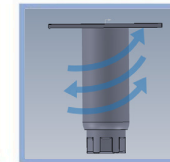

ADJUSTABLE LEVELERS



MAINTAINS CRITICAL TEMPERATURE

STANDARD FEATURES

- High Efficiency Motors
- High Efficiency Condensing Unit
- Removable Service Panels
- Electronic Control
- Designed to Maintain Product Temperatures at <math><41^{\circ}</math> F
- Electric Condensate Pan

OPTIONAL ACCESSORIES

- Corner Guards
- Corner Brackets
- Black Bumper
- Various Product Risers
- Magnetic Filter Screen
- 12" Adjustable Metal Shelf

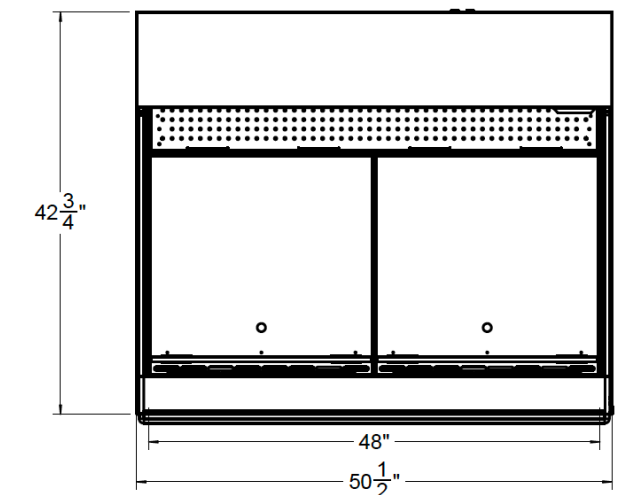
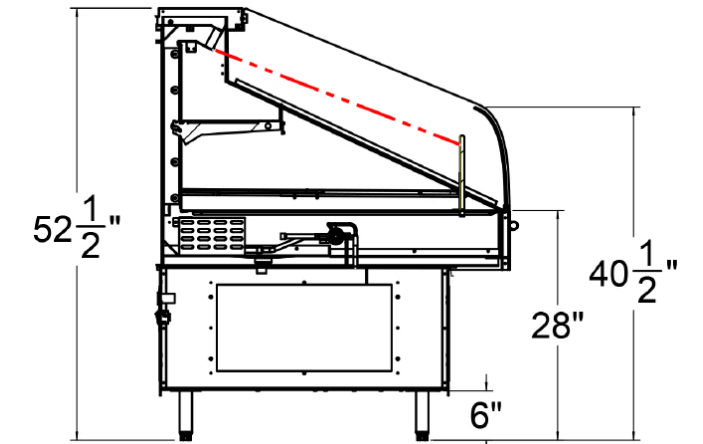

MODEL	DIMENSIONS*		POWER						
	A	B	V	Ph	Hz	MCA	MOP	HP	BTU/hr @ 75F
RBS146H	52 1/2"	45 3/4"	-	-	-	-	-	-	-



Please refer to our website to see our wide range of materials, finishes, merchandising foam, and accessories

*Dimensions are approximate and will vary based on wrap styles



V-SERIES SELF-CONTAINED REFRIGERATED CASES

CRITICAL
TEMP



V-SERIES SELF-CONTAINED REFRIGERATED CASE

DESCRIPTION

Our V-Series refrigerated display cases bring added value to any program and are available in metal finishes.

BEST USED FOR

- Spot Merchandising
- Promotional displays
- Convenience stores
- Prepackaged meals

FEATURES

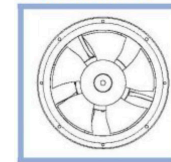

HIGH EFFICIENCY MOTORS

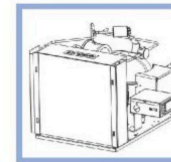

HIGH EFFICIENCY CONDENSING UNIT



MAINTAINS CRITICAL TEMPERATURE

STANDARD FEATURES

- High Efficiency Motors
- High Efficiency Condensing Unit
- Removable Service Panels
- Electronic Control
- Designed to Maintain Product Temperatures at <math><41^{\circ}</math> F
- Electric Condensate Pan

OPTIONAL ACCESSORIES

- Corner Guards
- Corner Brackets
- Black Bumper
- Various Product Risers
- Magnetic Filter Screen
- 12" Adjustable Metal Shelf

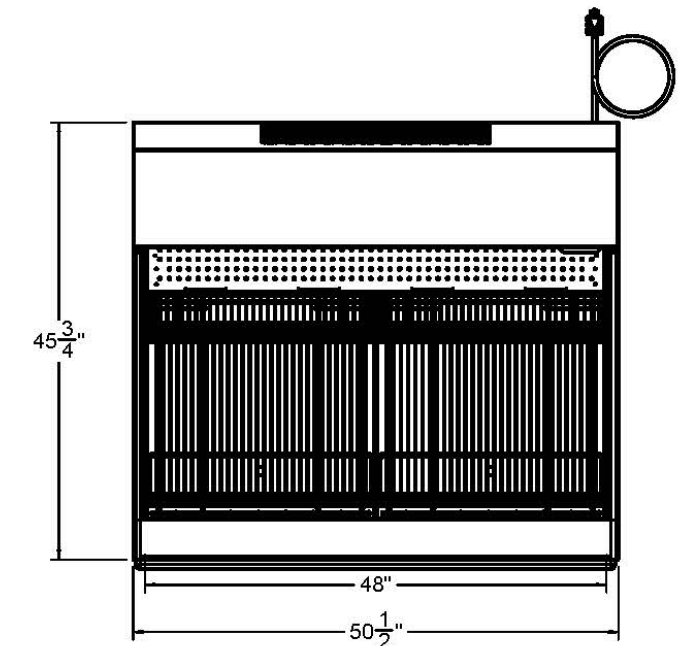
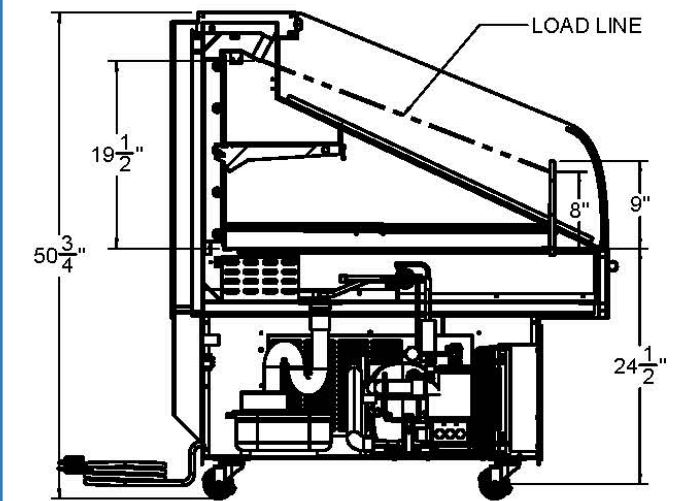

MODEL	DIMENSIONS*		POWER						
	A	B	V	Ph	Hz	MCA	MOP	HP	BTU/hr @ 75F
RBS046H	50 3/4"	45 3/4"	120	1	60	18.2	25	1/2	4750



Please refer to our website to see our wide range of materials, finishes, merchandising foam, and accessories

*Dimensions are approximate and will vary based on wrap styles

V-SERIES HIGH VISIBILITY REMOTE REFRIGERATED CASES

V-SERIES HIGH VISIBILITY REMOTE CASE

CRITICAL
TEMP



DESCRIPTION

Our V-Series refrigerated display cases bring added value to any program and are available in metal finishes.

BEST USED FOR

- Spot Merchandising
- Promotional displays
- Convenience stores
- Prepackaged meals

FEATURES

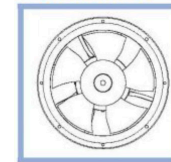

HIGH-EFFICIENCY MOTORS

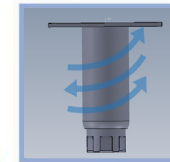

ADJUSTABLE LEVELERS



MAINTAINS CRITICAL TEMPERATURE

STANDARD FEATURES

- High Efficiency Motors
- High Efficiency Condensing Unit
- Removable Service Panels
- Electronic Control
- Designed to Maintain Product Temperatures at <math><41^{\circ}</math> F
- Electric Condensate Pan

OPTIONAL ACCESSORIES

- Corner Guards
- Corner Brackets
- Black Bumper
- Various Product Risers
- Magnetic Filter Screen
- 12" and 15" Adjustable Metal Shelves

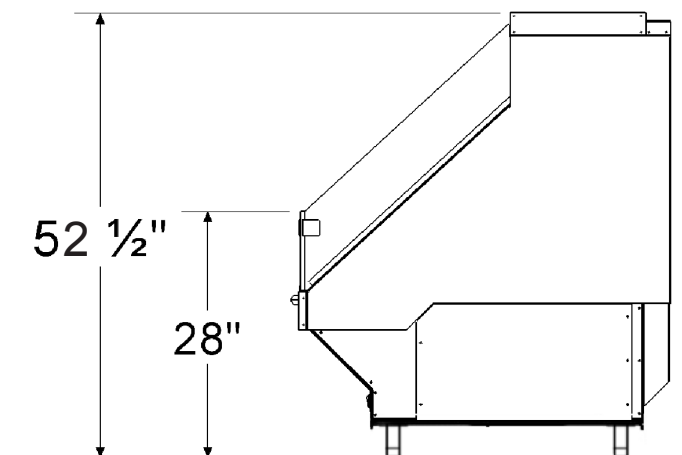
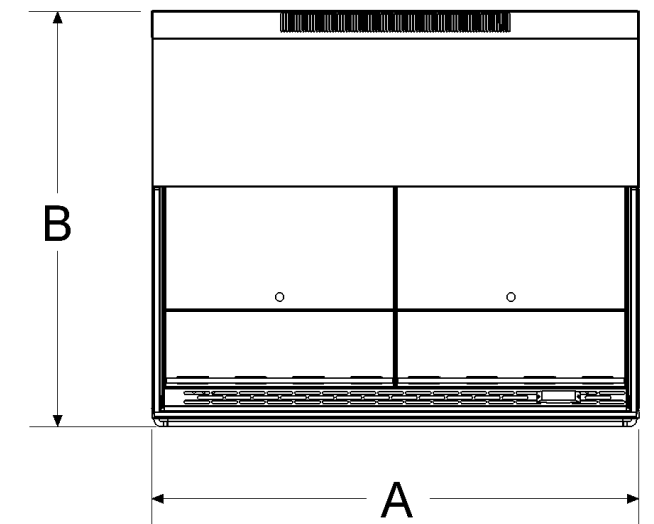

MODEL	DIMENSIONS*		POWER						
	A	B	V	Ph	Hz	MCA	MOP	HP	BTU/hr @ 75F
RBS134HV	52 1/2"	42 3/4"	-	-	-	-	-	-	-



Please refer to our website to see our wide range of materials, finishes, merchandising foam, and accessories

*Dimensions are approximate and will vary based on wrap styles



V-SERIES HIGH VISIBILITY SELF CONTAINED REFRIGERATED CASES

CRITICAL TEMP



Delivering a *fresh* experience

an  company

V-SERIES HIGH VISIBILITY SELF-CONTAINED CASE

DESCRIPTION

Our V-Series refrigerated display cases bring added value to any program and are available in metal finishes.

BEST USED FOR

- Spot Merchandising
- Promotional displays
- Convenience stores
- Prepackaged meals

FEATURES

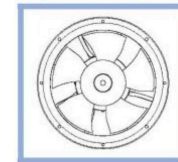

HIGH-EFFICIENCY MOTORS

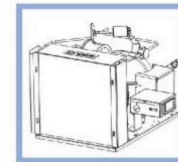

HIGH-EFFICIENCY CONDENSING UNIT



MAINTAINS CRITICAL TEMPERATURE

STANDARD FEATURES

- High Efficiency Motors
- High Efficiency Condensing Unit
- Removable Service Panels
- Electronic Control
- Designed to Maintain Product Temperatures at <41° F
- Electric Condensate Pan

OPTIONAL ACCESSORIES

- Corner Guards
- Corner Brackets
- Black Bumper
- Various Product Risers
- Magnetic Filter Screen
- 12" and 15" Adjustable Shelves

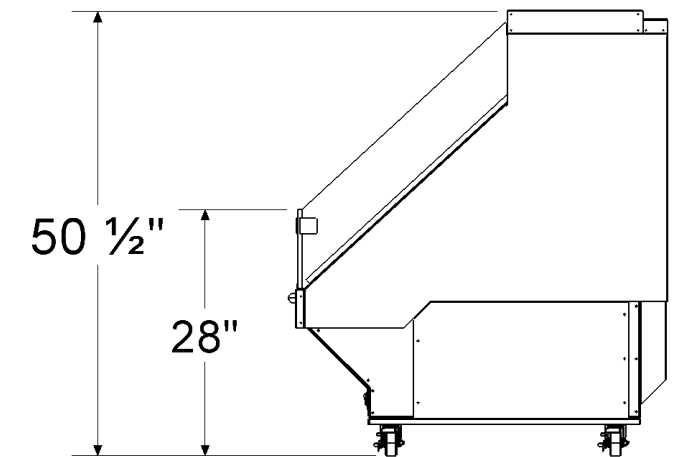
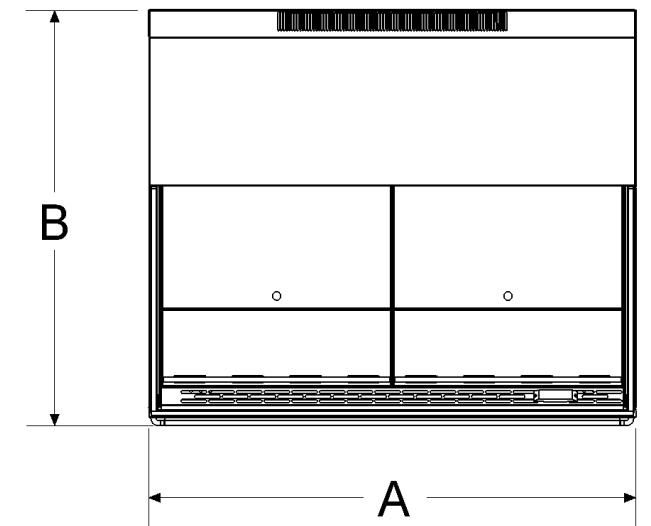

MODEL	DIMENSIONS*		POWER						
	A	B	V	Ph	Hz	MCA	MOP	HP	BTU/hr @ 75F
RBS034HV	50 1/2"	42 3/4"	120	1	60	19.0	25	-	-



Please refer to our website to see our wide range of materials, finishes, merchandising foam, and accessories

*Dimensions are approximate and will vary based on wrap styles

FRESH TO GO REFRIGERATED 3-SIDED ROUND CASES

TYPE II CERTIFIED



Critical
TEMP



FRESH TO GO REFRIGERATED 3-SIDED ROUND CASES

DESCRIPTION

Fresh To Go is our new line of refrigerated merchandisers that accommodate almost any store layout. Adjustable shelving allows you to fit a variety of products and create the perfect display. Flat back panel offers a number of configuration options.

BEST USED FOR

- Spot Merchandising
- Promotional displays
- Convenience stores
- Prepackaged meals

FEATURES



HEIGHT ADJUSTABLE SHELVES

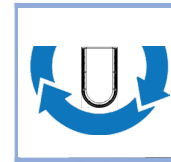

180° OF MERCHANDISING



EASY ACCESS CONTROLS

STANDARD FEATURES

- High Efficiency Motors
- Digital Solar Thermometer
- Removable Service Panels
- Electronic Control
- Designed to Maintain Product Temperatures at <41° F
- Electric Condensate Pan

OPTIONAL ACCESSORIES

- LED canopy lighting
- LED shelf lighting
- Custom Powdercoat options
- "Organics" product stops

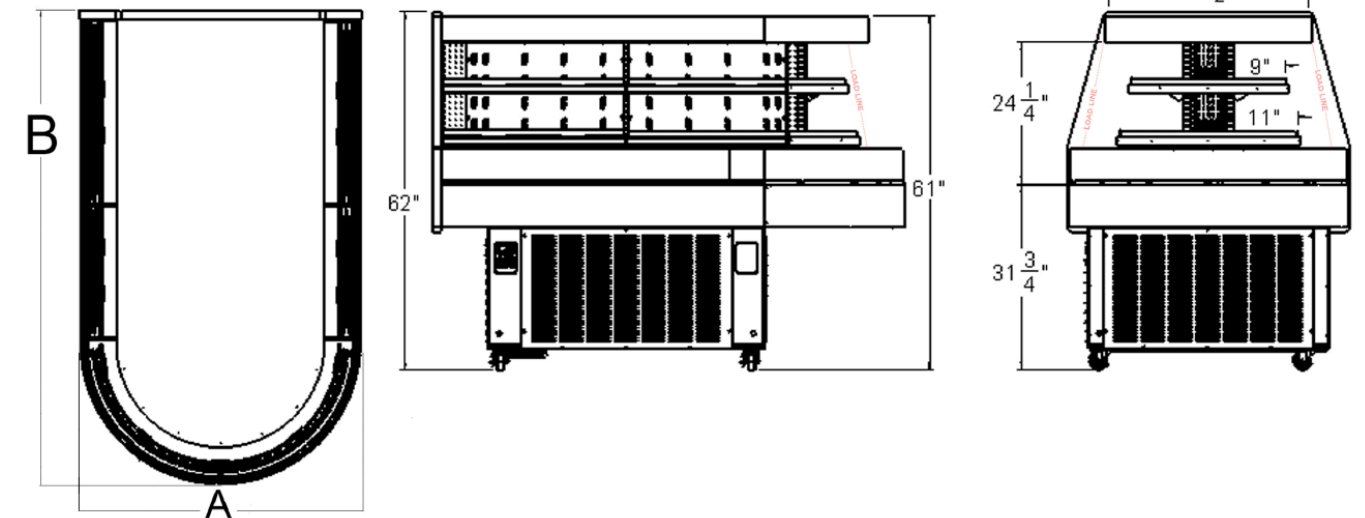

MODEL	DIMENSIONS*		POWER						
	A	B	V	Ph	Hz	MCA	MOP	HP	BTU/hr @ 75F
RIU046-62-FB	48 1/2"	82"	208	1	60	29.3	40	1 1/2	14700



Please refer to our website to see our wide range of materials, finishes, merchandising foam, and accessories

*Dimensions are approximate and will vary based on wrap styles

FRESH TO GO REFRIGERATED ROUND CASES

TYPE II CERTIFIED

Critical
TEMP



FRESH TO GO REFRIGERATED ROUND CASES

DESCRIPTION

Fresh To Go is our new line of refrigerated merchandisers that accommodate almost any store layout. These can be merchandised from 270, or a full 360 degrees! Adjust shelving up or down to create the perfect display.

BEST USED FOR

- Spot Merchandising
- Promotional displays
- Convenience stores
- Prepackaged meals

FEATURES



HEIGHT ADJUSTABLE SHELVES

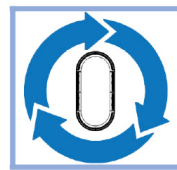

360° OF MERCHANDISING



EASY ACCESS CONTROLS

STANDARD FEATURES

- High Efficiency Motors
- Digital Solar Thermometer
- Removable Service Panels
- Electronic Control
- Designed to Maintain Product Temperatures at <41° F
- Electric Condensate Pan

OPTIONAL ACCESSORIES

- LED canopy lighting
- LED shelf lighting
- Custom Powdercoat options
- "Organics" product stops

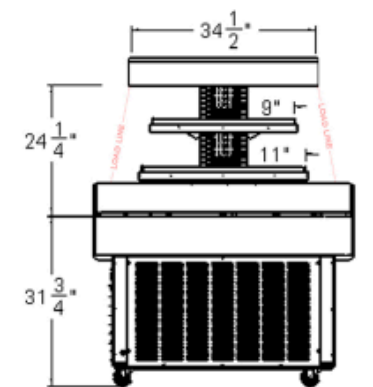
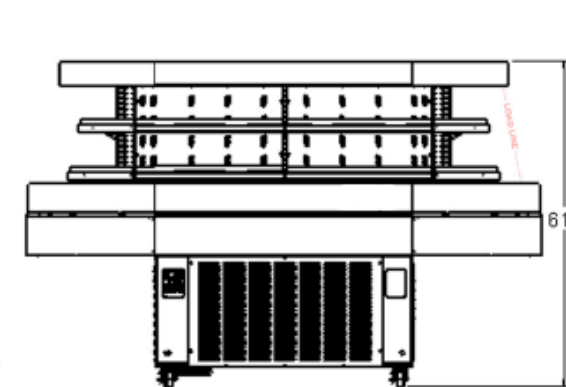
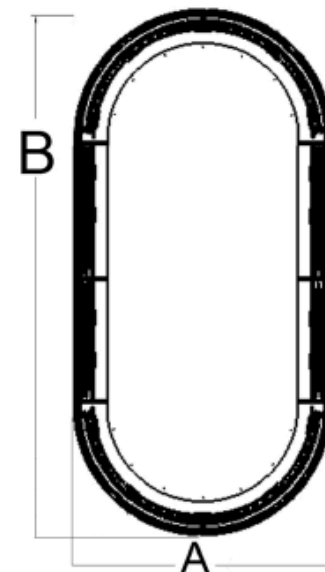

MODEL	DIMENSIONS*		POWER						
	A	B	V	Ph	Hz	MCA	MOP	HP	BTU/hr @ 75F
RIU048-62-F	48 1/2"	96"	208	1	60	40.8	60	2 1/2	23600



Please refer to our website to see our wide range of materials, finishes, merchandising foam, and accessories

*Dimensions are approximate and will vary based on wrap styles

SINGLE DECK HIGH-VISIBILITY REFRIGERATED CASES

10" CRITICAL TEMP DEPTH

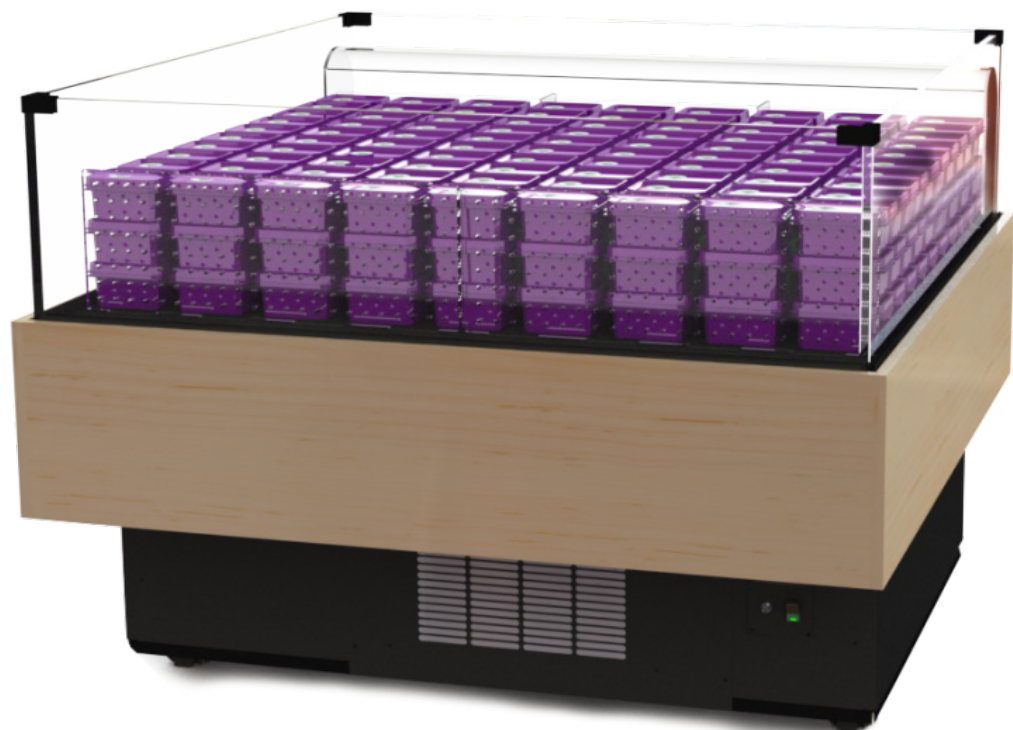

SINGLE DECK HIGH-VISIBILITY REFRIGERATED CASES

DESCRIPTION

JSI's Refrigerated Cases will help reduce shrink and drive sales higher in your fresh departments. These merchandisers are available in our full range of styles and finish options to perfectly match your store's décor.

BEST USED FOR:

- Spot Merchandising
- Front Entry
- Refrigerated Space in Groupings
- Critical Temp Product

FEATURES

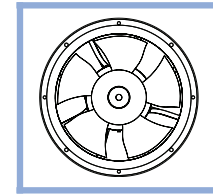

High-Efficiency Fan Motors

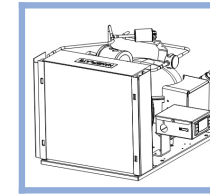

High-Efficiency Condensing Unit

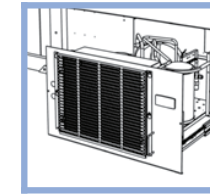

Slide-Out Service Drawer

STANDARD FEATURES

- Electronic Control
- Removable Service Panels
- Digital Solar Thermometer
- Designed to Maintain Product Temperatures at <41°F
- Electric Condensate Pan

OPTIONAL ACCESSORIES

- Corner Guards
- Corner Brackets
- Black Bumper
- Various Product Risers
- Magnetic Filter Screen
- Available in metal or wood wrap and in a variety of finishes

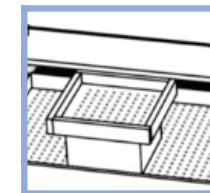

Pedestal Riser

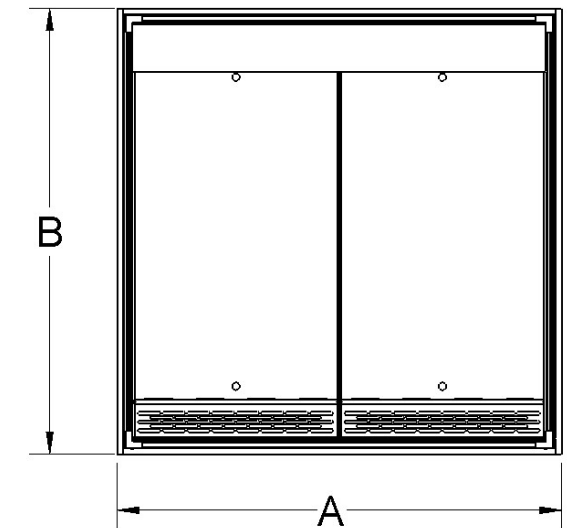
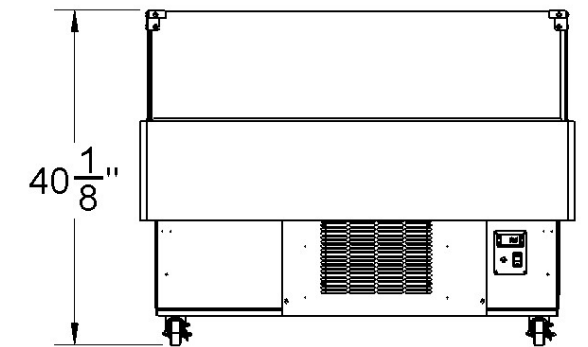

MODEL	DIMENSIONS*		POWER						
	A	B	V	Ph	Hz	AMPS	FUSE SIZE	HP	BTU/hr @ 75F
RBD0331HV	40 1/2"	34 1/2"	110	1	60	12.9	20	1/2	4500
RBD0441HV	52"	55"	110	1	60	19	20	1/2	4750
RBD0341HV	48"	36"	110	1	60	14.3	20	1/2	4750
RBD0361HV	76"	34 1/2"	110	1	60	15.47	20	1/2	4750
RBD0381HV	100"	34 1/2"	220	1	60	-	20	-	4750



Please refer to our website to see our wide range of materials, finishes, merchandising foam, and accessories

*Dimensions are approximate and will vary based on wrap styles

SINGLE DECK REFRIGERATED CASES

5" CRITICAL TEMP DEPTH



SINGLE DECK REFRIGERATED CASES

DESCRIPTION

JSI's Refrigerated Cases will help reduce shrink and drive sales higher in your fresh departments. These merchandisers are available in our full range of styles and finish options to perfectly match your store's décor.

BEST USED FOR:

- Spot Merchandising
- Front Entry
- Mix & Match with Refrigerated and Ambient Fixtures
- Critical Temp Product

FEATURES

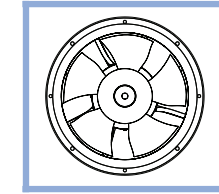

High-Efficiency Fan Motors

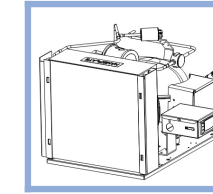

High-Efficiency Condensing Unit

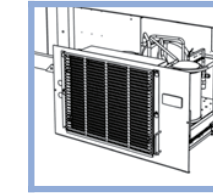

Slide-Out Service Drawer

STANDARD FEATURES

- Electronic Control
- Removable Service Panels
- Digital Solar Thermometer
- Designed to Maintain Product Temperatures at <41°F
- Electric Condensate Pan

OPTIONAL ACCESSORIES

- Corner Guards
- Corner Brackets
- Black Bumper
- Various Product Risers
- Magnetic Filter Screen
- Available in metal or wood wrap and in a variety of finishes

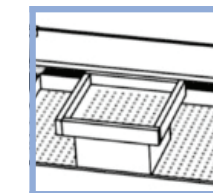

Pedestal Riser

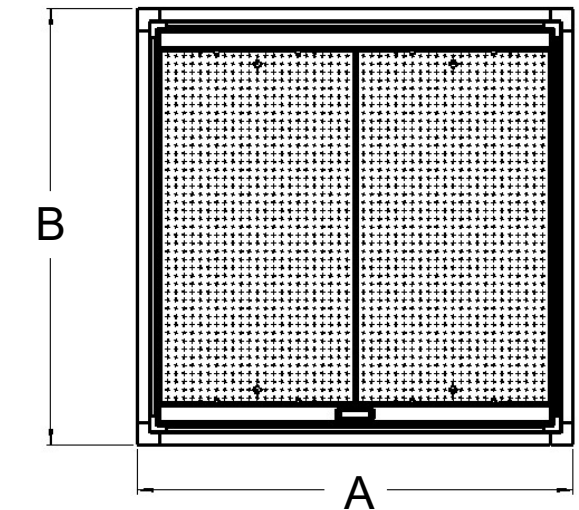
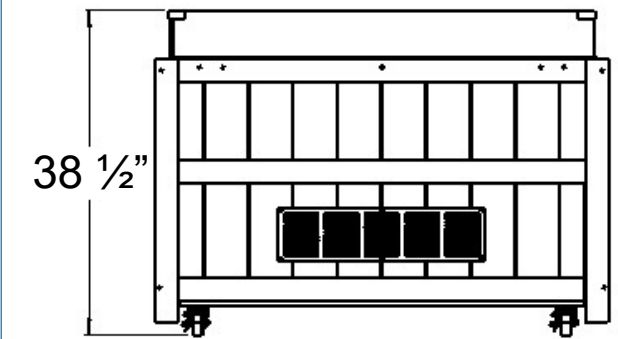

MODEL	DIMENSIONS*		POWER						
	A	B	V	Ph	Hz	MCA	MOP	HP	BTU/hr @ 75F
RBD0331	36"	36"	120	1	60	13.6	15	1/3	2920
RBD0441	53 1/2"	53 1/2"	120	1	60	18.6	25	1/2	4750
RBD0341	48"	36"	120	1	60	17.4	25	1/2	4750
RBD0361	72"	36"	120	1	60	18.6	25	1/2	4750
RBD0381	96"	36"	208	1	60	17.7	20	3/4	6090



Please refer to our website to see our wide range of materials, finishes, merchandising foam, and accessories

*Dimensions are approximate and will vary based on wrap styles

SELF-CONTAINED REFRIGERATED ORCHARD BINS

AVAILABLE IN 6' - 8' SECTIONS

10" CRITICAL TEMP DEPTH



Delivering a *fresh* experience

an  company

SELF-CONTAINED REFRIGERATED ORCHARD BINS

DESCRIPTION

JSI's Refrigerated Orchard Bins are available in our full range of styles and finish options to perfectly match your entire department. The design allows for maximum product visibility and offers adjustable shelving for a variety of merchandising options.

FEATURES

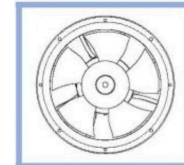

HIGH EFFICIENCY MOTOR

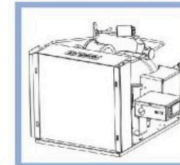

HIGH EFFICIENCY CONDENSING UNIT

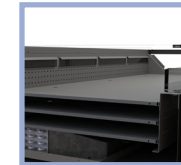

ADJUSTABLE DECK HEIGHT

BEST USED FOR

- Front Entry
- Spot Merchandising
- Island Groupings
- Mix & Match with Refrigerated and Ambient Fixtures

STANDARD FEATURES

- High Efficiency Motors
- Digital Solar Thermometer
- Removable Service Panels
- Electronic Control
- Dual Temperature Switch
- Designed to Maintain Product Temperatures at <41° F
- Electric Condensate Pan
- Adjustable Deck (3 Height Options)

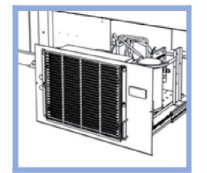

SLIDE-OUT SERVICE DRAWER

OPTIONAL ACCESSORIES

- Metal Toe kicks
- Corner Guards and Bumper
- Adjustable Deck
- Price Tag Molding
- Magnetic Filter Screen
- Available in many laminates or with front accent trim.

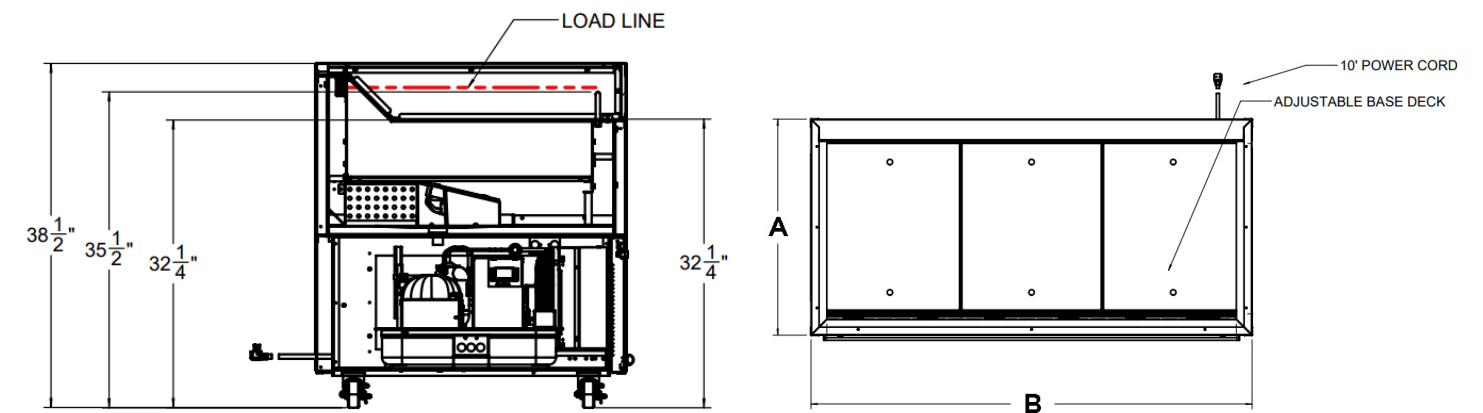

MODEL	DIMENSIONS*		POWER						
	A	B	V	Ph	Hz	MCA	MOP	HP	BTU/hr @ 75° F
RBD0361	34 3/4"	72"	208	1	60	15.3	20	3/4	6650
RBD0381	34 3/4"	96"	208	1	60	18.9	25	1	9150

Please refer to our "Styles, Groupings, Stains and Accessories" brochure to see our wide range of materials, finishes, merchandising foam, and accessories.

*Dimensions are approximate and will vary based on wrap styles



2-TIER REFRIGERATED CASES

5" CRITICAL TEMP DEPTH

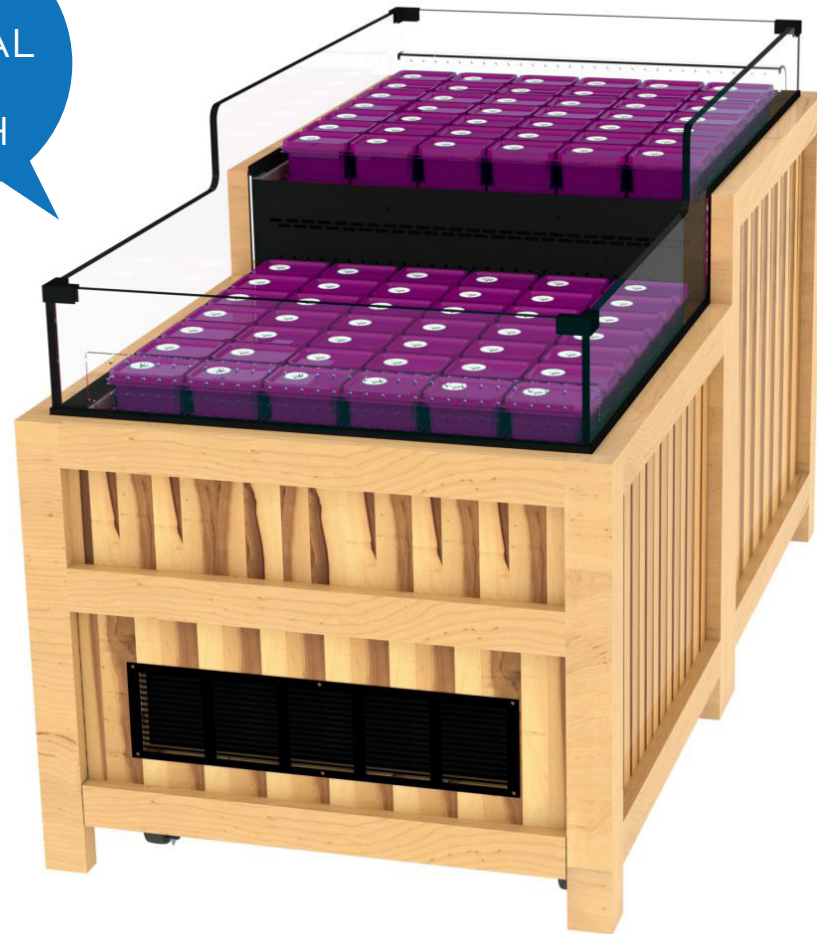

2-TIER REFRIGERATED CASE

DESCRIPTION

JSI's Refrigerated Cases will help reduce shrink and drive sales higher in your fresh departments. These merchandisers are available in our full range of styles and finish options to perfectly match your store's décor.

BEST USED FOR:

- Spot Merchandising
- Front Entry
- Mix & Match with Refrigerated and Ambient Fixtures
- Critical Temp Product

FEATURES

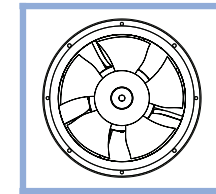

High-Efficiency Fan Motors

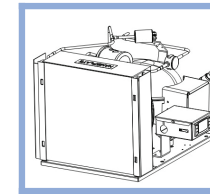

High-Efficiency Condensing Unit

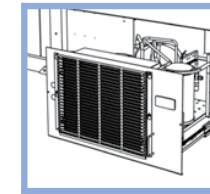

Slide-Out Service Drawer

STANDARD FEATURES

- Electronic Control
- Removable Service Panels
- Digital Solar Thermometer
- Designed to Maintain Product Temperatures at <41°F
- Electric Condensate Pan

OPTIONAL ACCESSORIES

- Corner Guards
- Corner Brackets
- Black Bumper
- Various Product Risers
- Magnetic Filter Screen
- Available in metal or wood wrap and in a variety of finishes

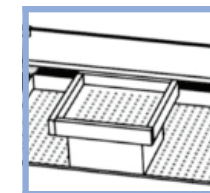

Pedestal Riser

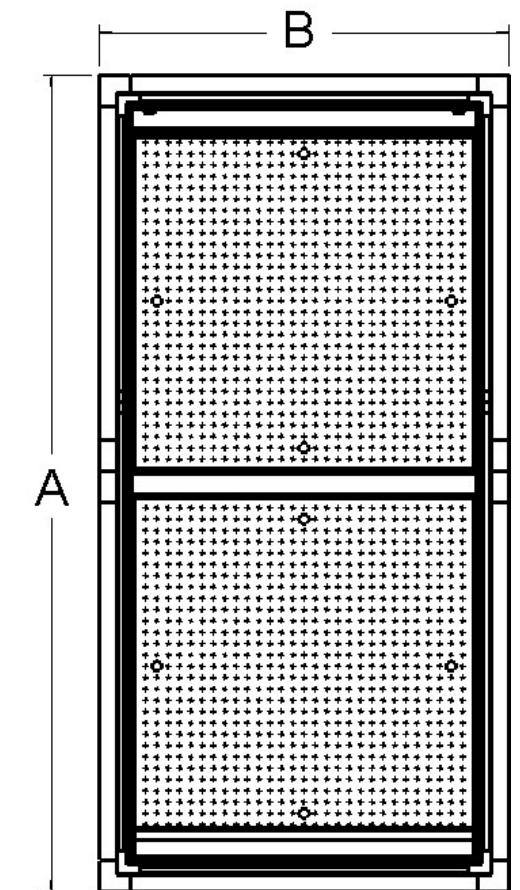
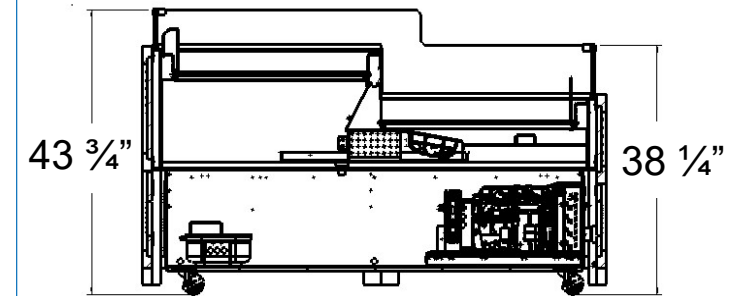

MODEL	DIMENSIONS*		POWER						
	A	B	V	Ph	Hz	MCA	MOP	HP	BTU/hr @ 75F
RBD0362	72"	36"	120	1	60	18.2	25	½	4750

Please refer to our website to see our wide range of materials, finishes, merchandising foam, and accessories

*Dimensions are approximate and will vary based on wrap styles



2-TIER HIGH-VISIBILITY REFRIGERATED CASES

AVAILABLE IN 5' - 6' LENGTHS

7.5" CRITICAL TEMP DEPTH



2-TIER HIGH-VISIBILITY REFRIGERATED CASES

DESCRIPTION

JSI's Refrigerated Cases will help reduce shrink and drive sales higher in your fresh departments. These merchandisers are available in our full range of styles and finish options to perfectly match your store's décor.

BEST USED FOR:

- Spot Merchandising
- Front Entry
- Mix & Match with Refrigerated and Ambient Fixtures
- Critical Temp Product

FEATURES

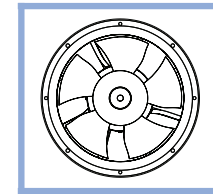

High-Efficiency Fan Motors

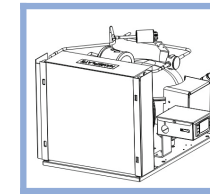

High-Efficiency Condensing Unit

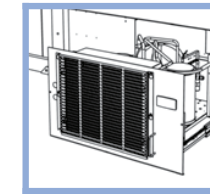

Slide-Out Service Drawer

STANDARD FEATURES

- Electronic Control
- Removable Service Panels
- Digital Solar Thermometer
- Designed to Maintain Product Temperatures at <41°F
- Electric Condensate Pan

OPTIONAL ACCESSORIES

- Corner Guards
- Corner Brackets
- Black Bumper
- Various Product Risers
- Magnetic Filter Screen
- Available in metal or wood wrap and in a variety of finishes

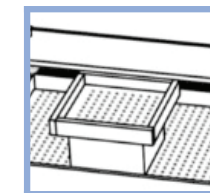

Pedestal Riser

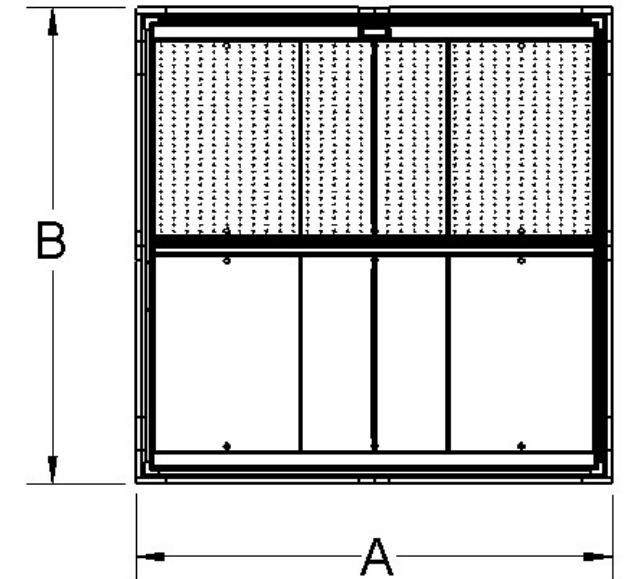
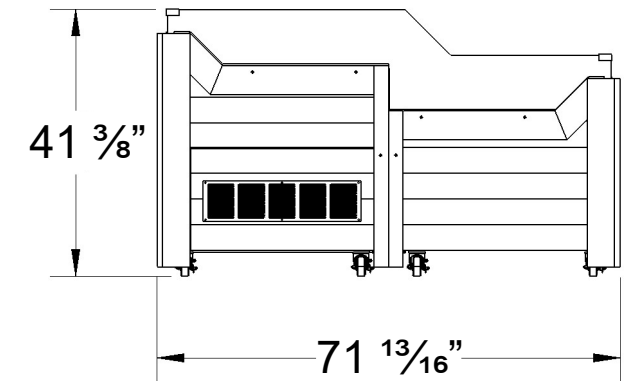

MODEL	DIMENSIONS*		POWER						
	A	B	V	Ph	Hz	MCA	MOP	HP	BTU/hr @ 75F
RBD0552	60"	60"	208	1	60	18.8	25	1	9180
RBD0662	72 3/4"	72 3/4"	208	1	60	18.3	25	1	9180



Please refer to our website to see our wide range of materials, finishes, merchandising foam, and accessories

*Dimensions are approximate and will vary based on wrap styles

3-TIER REFRIGERATED CASES

2.5" CRITICAL TEMP DEPTH

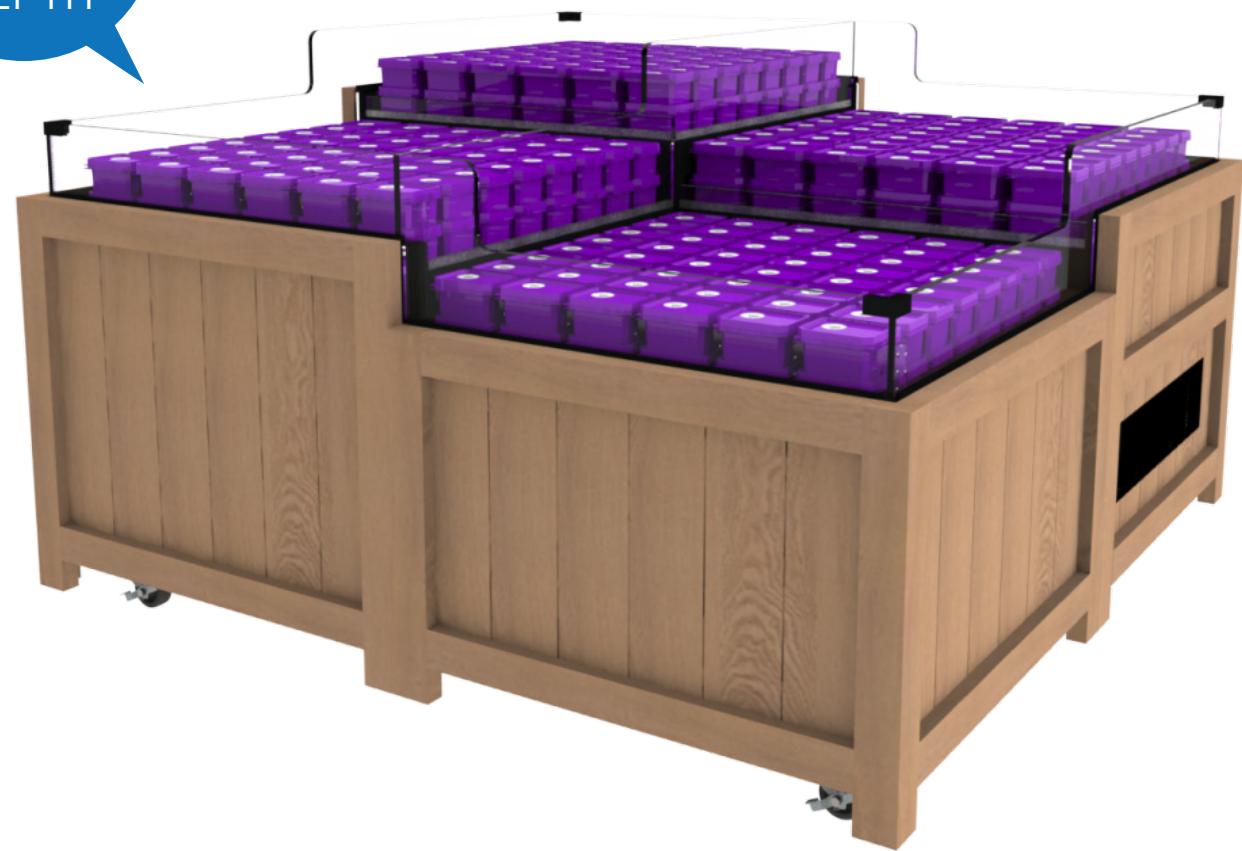

3-TIER REFRIGERATED CASES

DESCRIPTION

JSI's Refrigerated Cases will help reduce shrink and drive sales higher in your fresh departments. These merchandisers are available in our full range of styles and finish options to perfectly match your store's décor.

BEST USED FOR:

- Spot Merchandising
- Front Entry
- Mix & Match with Refrigerated and Ambient Fixtures
- Critical Temp Product

FEATURES

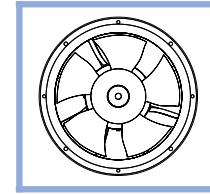

High-Efficiency Fan Motors

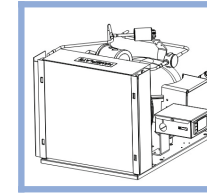

High-Efficiency Condensing Unit

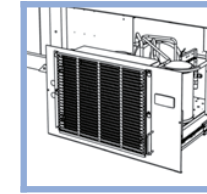

Slide-Out Service Drawer

STANDARD FEATURES

- Electronic Control
- Removable Service Panels
- Digital Solar Thermometer
- Designed to Maintain Product Temperatures at <41°F
- Electric Condensate Pan

OPTIONAL ACCESSORIES

- Corner Guards
- Corner Brackets
- Black Bumper
- Various Product Risers
- Magnetic Filter Screen
- Available in metal or wood wrap and in a variety of finishes

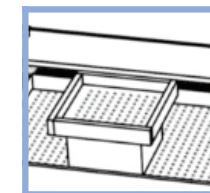

Pedestal Riser

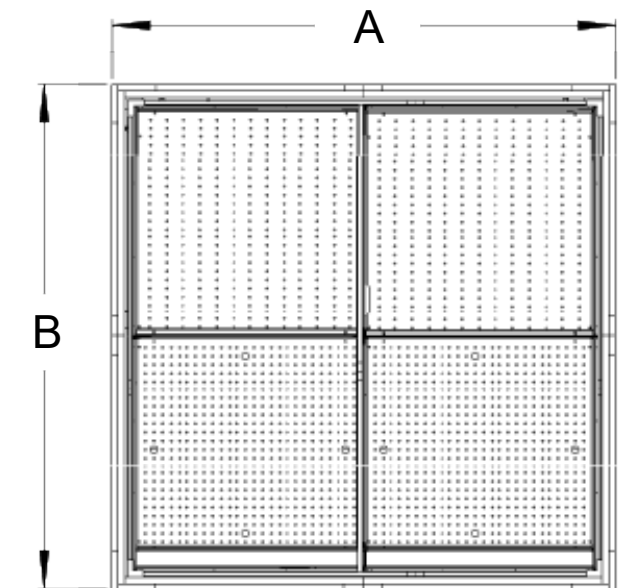
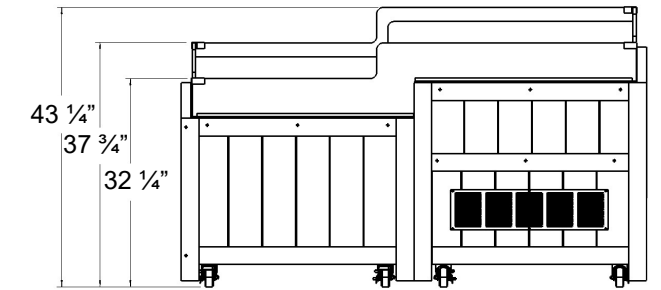

MODEL	DIMENSIONS*		POWER						
	A	B	V	Ph	Hz	MCA	MOP	HP	BTU/hr @ 75F
RBD0553	60"	60"	208	1	60	18.8	25	1	9180
RBD0663	72 3/4"	72 3/4"	208	1	60	18.8	25	1	9180



Please refer to our website to see our wide range of materials, finishes, merchandising foam, and accessories

*Dimensions are approximate and will vary based on wrap styles

LOW PROFILE REFRIGERATED SLANT CASES

AVAILABLE IN 2' - 4' LENGTHS

Critical
TEMP



LOW PROFILE REFRIGERATED SLANT CASES

DESCRIPTION

JSI's critical temp Refrigerated Slant Cases are available in our full range of styles and finish options to perfectly match your entire department.

BEST USED FOR:

- Spot Merchandising
- Front Entry
- Mix & Match with Refrigerated and Ambient Fixtures
- Critical Temp Product

FEATURES



Electronic Controls

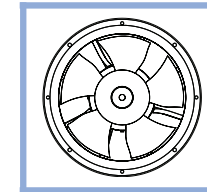

High-Efficiency Fan Motors

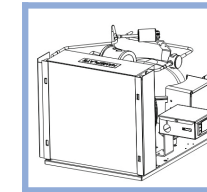

High-Efficiency Condensing Unit

STANDARD FEATURES

- High Efficiency Motors
- Digital Solar Thermometer
- Removable Service Panels
- Electronic Control
- Designed to Maintain Product Temperatures at <41°F
- Electric Condensate Pan

OPTIONAL ACCESSORIES

- Merchandising Steps
- Various Shelf Styles and Sizes
- Corner Guards and Brackets
- Adjustable Wire Deck
- Foam Pad
- Price Tag Molding
- Magnetic Filter Screen
- Available in metal or wood wrap and in a variety of finishes

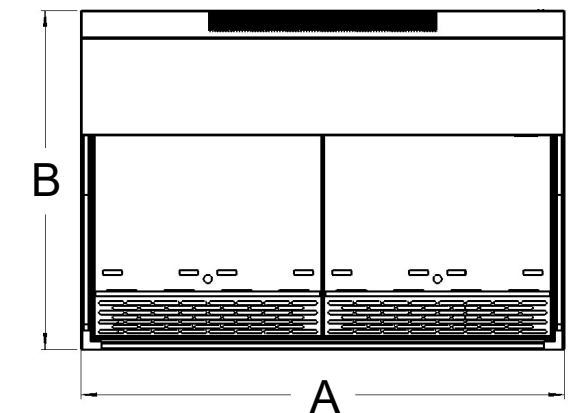
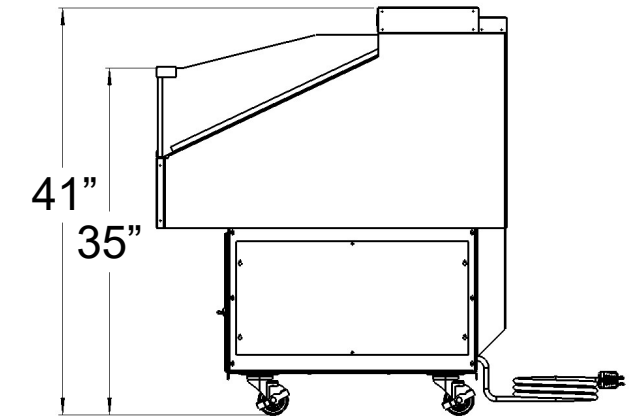

MODEL	DIMENSIONS*		POWER						
	A	B	V	Ph	Hz	MCA	MOP	HP	BTU/hr @ 75F
RBS032L	24"	36"	120	1	60	12.6	20	1/3	2920
RBS033L	36"	36"	120	1	60	13.7	20	1/3	2920
RBS034L	48"	36"	120	1	60	18.2	25	1/2	4750
RBS042L	24"	48"	120	1	60	13.7	20	1/3	2920
RBS044L	48"	48"	120	1	60	18.2	25	1/2	4750



Please refer to our website to see our wide range of materials, finishes, merchandising foam, and accessories

*Dimensions are approximate and will vary based on wrap styles



HIGH PROFILE REFRIGERATED SLANT CASES

AVAILABLE IN 2' - 4' LENGTHS

Critical
TEMP



HIGH PROFILE REFRIGERATED SLANT CASES

DESCRIPTION

JSI's critical temp Refrigerated Slant Cases are available in our full range of styles and finish options to perfectly match your entire department.

BEST USED FOR:

- Spot Merchandising
- Front Entry
- Mix & Match with Refrigerated and Ambient Fixtures
- Critical Temp Product

FEATURES



Electronic Controls

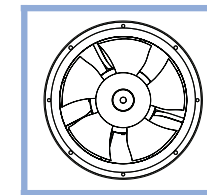

High-Efficiency Fan Motors

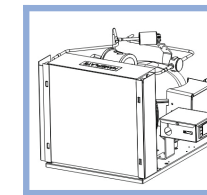

High-Efficiency Condensing Unit

STANDARD FEATURES

- High Efficiency Motors
- Digital Solar Thermometer
- Removable Service Panels
- Electronic Control
- Designed to Maintain Product Temperatures at <41°F
- Electric Condensate Pan

OPTIONAL ACCESSORIES

- Merchandising Steps
- Various Shelf Styles and Sizes
- Corner Guards and Brackets
- Adjustable Wire Deck
- Foam Pad
- Price Tag Molding
- Magnetic Filter Screen
- Available in metal or wood wrap and in a variety of finishes

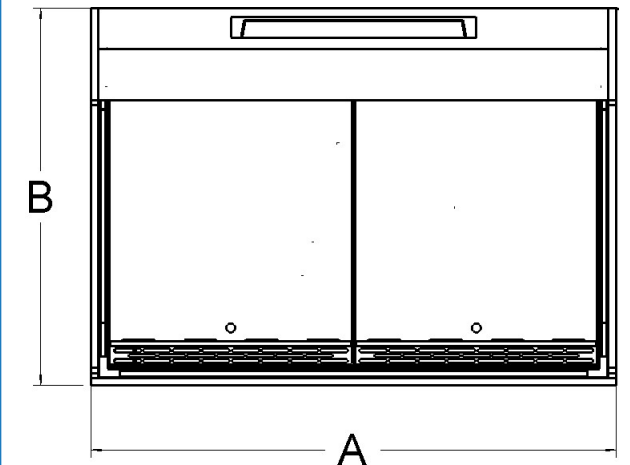
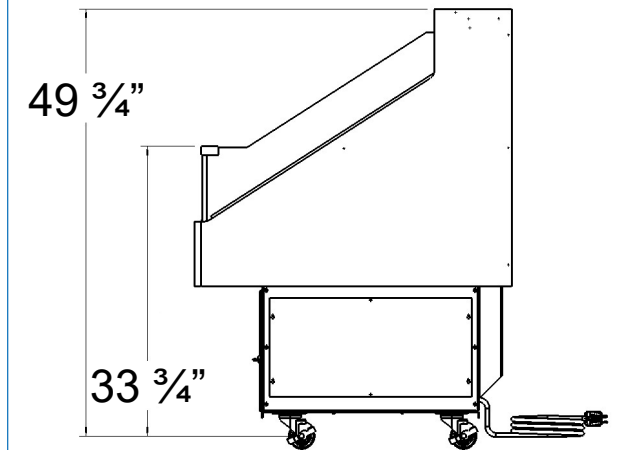

MODEL	DIMENSIONS*		POWER						
	A	B	V	Ph	Hz	MCA	MOP	HP	BTU/hr @ 75F
RBS032H	24"	36"	120	1	60	12.6	20	1/5	2920
RBS033H	36"	36"	120	1	60	13.7	20	1/5	2920
RBS034H	48"	36"	120	1	60	18.2	25	1/2	4750
RBS042H	24"	48"	120	1	60	13.7	20	1/5	2920
RBS044H	48"	48"	120	1	60	18.2	25	1/2	4750



Please refer to our website to see our wide range of materials, finishes, merchandising foam, and accessories

*Dimensions are approximate and will vary based on wrap styles

41" HIGH-VISIBILITY REFRIGERATED SLANT CASES

AVAILABLE IN 2' - 4' LENGTHS

Critical
TEMP



41" H HIGH-VISIBILITY REFRIGERATED SLANT CASES

DESCRIPTION

JSI's critical temp Refrigerated Slant Cases are available in our full range of styles and finish options to perfectly match your entire department. The low front design allows for maximum product visibility and a variety of merchandising options.

BEST USED FOR:

- Spot Merchandising
- Front Entry
- Mix & Match with Refrigerated and Ambient Fixtures
- Critical Temp Product

FEATURES



Electronic Controls

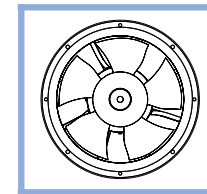

High-Efficiency Fan Motors

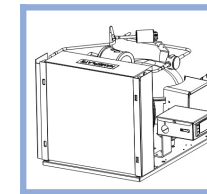

High-Efficiency Condensing Unit

STANDARD FEATURES

- High Efficiency Motors
- Digital Solar Thermometer
- Removable Service Panels
- Electronic Control
- Designed to Maintain Product Temperatures at <41°F
- Electric Condensate Pan

OPTIONAL ACCESSORIES

- Merchandising Steps
- Various Shelf Styles and Sizes
- Corner Guards and Brackets
- Adjustable Wire Deck
- Foam Pad
- Price Tag Molding
- Magnetic Filter Screen
- Available in metal or wood wrap and in a variety of finishes

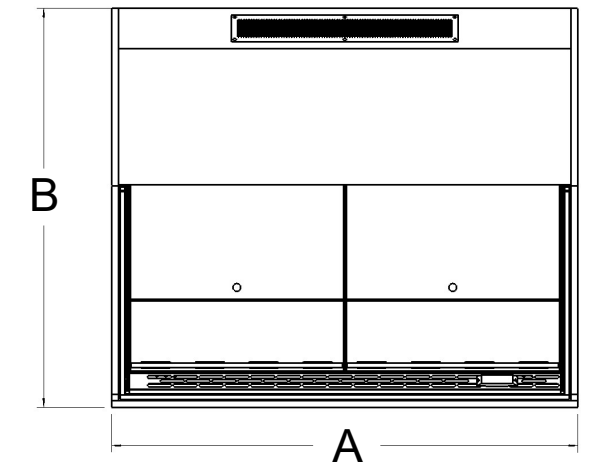
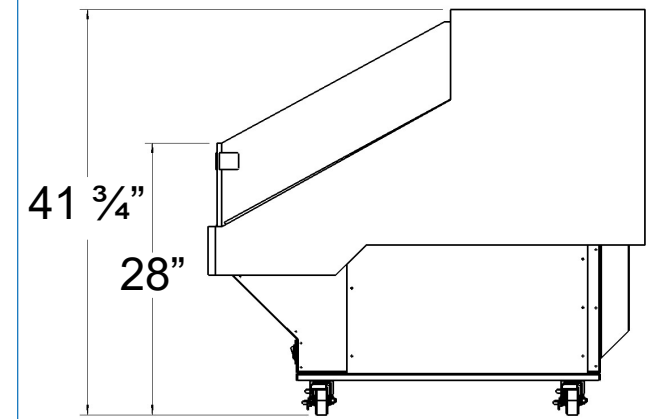

MODEL	DIMENSIONS*		POWER						
	A	B	V	Ph	Hz	MCA	MOP	HP	BTU/hr @ 75F
RBS032HV-41	24"	44 1/2"	120	1	60	12.7	20	1/3	3300
RBS033HV-41	38"	44 1/2"	120	1	60	12.7	20	1/3	3300
RBS034HV-41	50 1/2"	44 1/2"	120	1	60	19	25	1/2	5280



2017
DOE
COMPLIANT

Please refer to our website to see our wide range of materials, finishes, merchandising foam, and accessories

*Dimensions are approximate and will vary based on wrap styles



49" HIGH-VISIBILITY REFRIGERATED SLANT CASES

AVAILABLE IN 6' - 12' LENGTHS

Critical
TEMP



49" H HIGH-VISIBILITY REFRIGERATED SLANT CASES

DESCRIPTION

JSI's critical temp Refrigerated Slant Cases are available in our full range of styles and finish options to perfectly match your entire department. The low front design allows for maximum product visibility and a variety of merchandising options.

BEST USED FOR:

- Front Entry
- Island Groupings
- Mix & Match with Refrigerated and Ambient Fixtures
- Berries

FEATURES



Electronic Controls

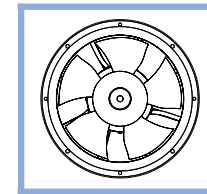

High-Efficiency Fan Motors

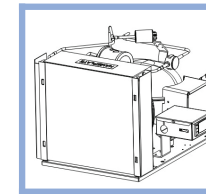

High-Efficiency Condensing Unit

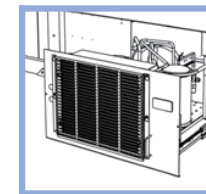

Slide-Out Service Drawer

STANDARD FEATURES

- High Efficiency Motors
- Digital Solar Thermometer
- Removable Service Panels
- Electronic Control
- Designed to Maintain Product Temperatures at <41°F
- Electric Condensate Pan

OPTIONAL ACCESSORIES

- Merchandising Steps
- Various Shelf Styles and Sizes
- Corner Guards and Brackets
- Adjustable Wire Deck
- Foam Pad
- Price Tag Molding
- Magnetic Filter Screen
- Available in metal or wood wrap and in a variety of finishes

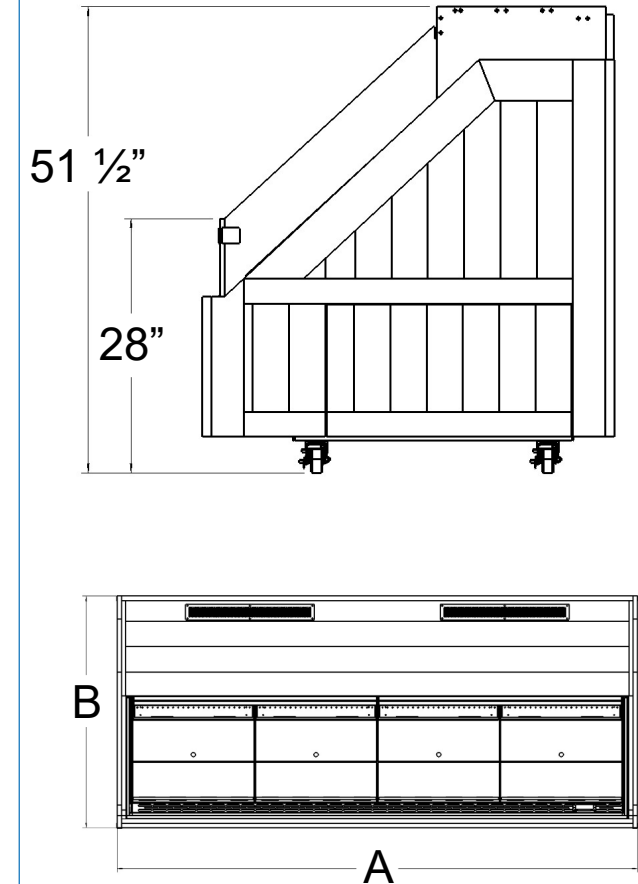

MODEL	DIMENSIONS*		POWER						
	A	B	V	Ph	Hz	MCA	MOP	HP	BTU/hr @ 75F
RBS036HV-49	74 1/2"	44 1/2"	208	1	60	15.3	20	3/4	7660
RBS038HV-49	101"	44 1/2"	208	1	60	18.5	25	1	9180
RBS0310HV-49	125 1/2"	44 1/2"	208	1	60	21.3	25	1 1/4	11900
RBS0312HV-49	149 1/2"	44 1/2"	208	1	60	23.3	30	1 1/4	11900



Please refer to our website to see our wide range of materials, finishes, merchandising foam, and accessories

*Dimensions are approximate and will vary based on wrap styles

56" HIGH-VISIBILITY REFRIGERATED SLANT CASES

AVAILABLE IN 2' - 4' LENGTHS

Critical
TEMP



56" H HIGH-VISIBILITY REFRIGERATED SLANT CASES

DESCRIPTION

JSI's critical temp Refrigerated Slant Cases are available in our full range of styles and finish options to perfectly match your entire department. The low front design allows for maximum product visibility and a variety of merchandising options.

BEST USED FOR:

- Spot Merchandising
- Front Entry
- Mix & Match with Refrigerated and Ambient Fixtures
- Critical Temp Product

FEATURES



Electronic Controls

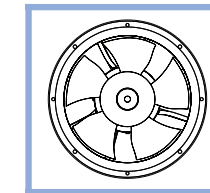

High-Efficiency Fan Motors

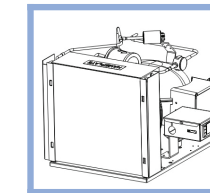

High-Efficiency Condensing Unit

STANDARD FEATURES

- High Efficiency Motors
- Digital Solar Thermometer
- Removable Service Panels
- Electronic Control
- Designed to Maintain Product Temperatures at <41°F
- Electric Condensate Pan

OPTIONAL ACCESSORIES

- Merchandising Steps
- Various Shelf Styles and Sizes
- Corner Guards and Brackets
- Adjustable Wire Deck
- Foam Pad
- Price Tag Molding
- Magnetic Filter Screen
- Available in metal or wood wrap and in a variety of finishes

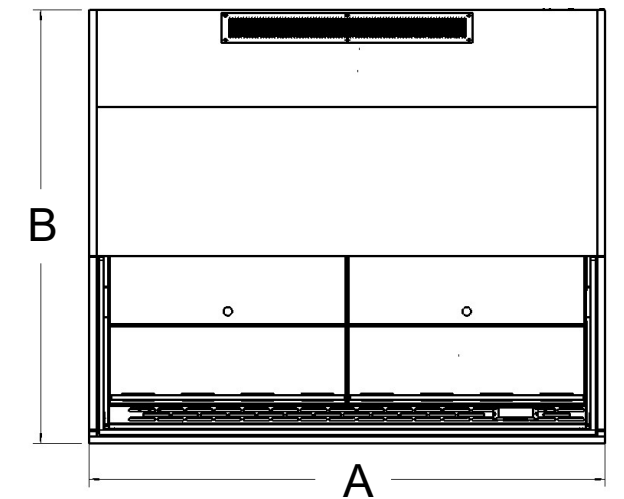
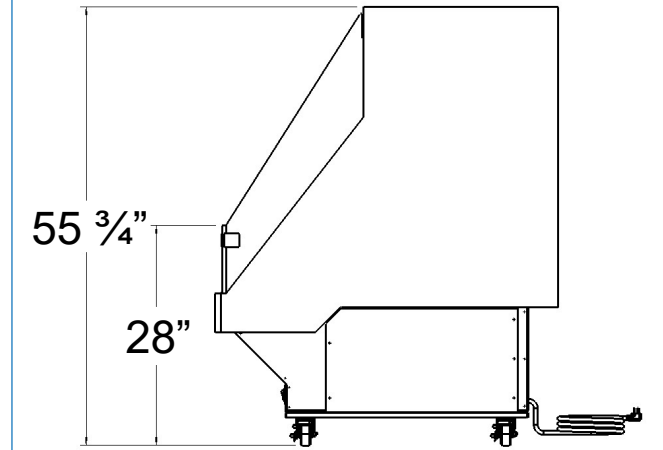

MODEL	DIMENSIONS*		POWER						
	A	B	V	Ph	Hz	MCA	MOP	HP	BTU/hr @ 75F
RBS032HV-56	24"	44 1/2"	120	1	60	12.7	20	1/5	3300
RBS033HV-56	38"	44 1/2"	120	1	60	12.7	20	1/5	3300
RBS034HV-56	50 1/2"	44 1/2"	120	1	60	19	25	1/2	5280



Please refer to our website to see our wide range of materials, finishes, merchandising foam, and accessories

*Dimensions are approximate and will vary based on wrap styles



62" HIGH-VISIBILITY REFRIGERATED SLANT CASES

AVAILABLE IN 2' - 4' LENGTHS

Critical
TEMP



62" H HIGH-VISIBILITY REFRIGERATED SLANT CASES

DESCRIPTION

JSI's critical temp Refrigerated Slant Cases are available in our full range of styles and finish options to perfectly match your entire department. The low front design allows for maximum product visibility and a variety of merchandising options.

BEST USED FOR:

- Spot Merchandising
- Front Entry
- Mix & Match with Refrigerated and Ambient Fixtures
- Critical Temp Product

FEATURES



Electronic Controls

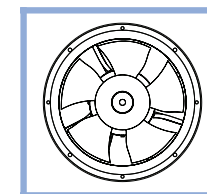

High-Efficiency Fan Motors

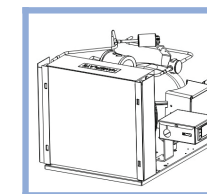

High-Efficiency Condensing Unit

STANDARD FEATURES

- High Efficiency Motors
- Digital Solar Thermometer
- Removable Service Panels
- Electronic Control
- Designed to Maintain Product Temperatures at <41°F
- Electric Condensate Pan

OPTIONAL ACCESSORIES

- Merchandising Steps
- Various Shelf Styles and Sizes
- Corner Guards and Brackets
- Adjustable Wire Deck
- Foam Pad
- Price Tag Molding
- Magnetic Filter Screen
- Available in metal or wood wrap and in a variety of finishes

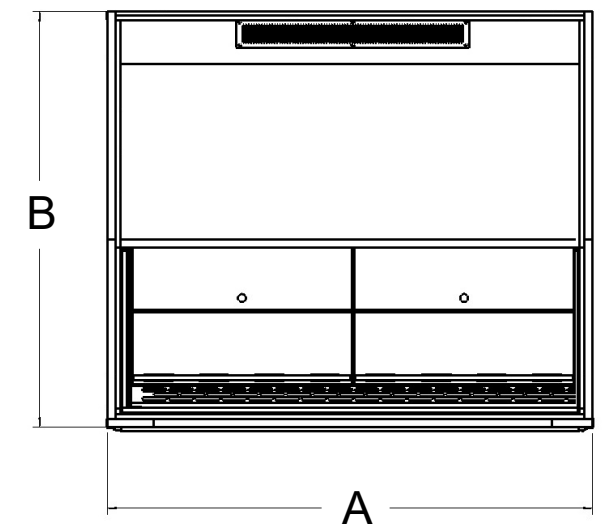
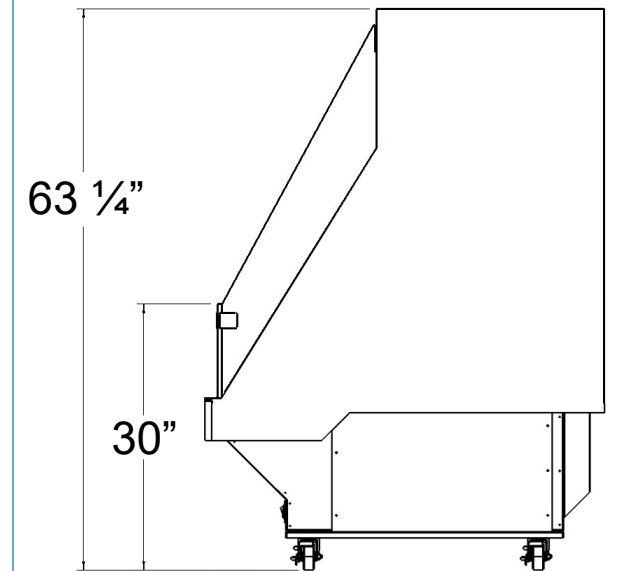

MODEL	DIMENSIONS*		POWER						
	A	B	V	Ph	Hz	MCA	MOP	HP	BTU/hr @ 75F
RBS032HV-62	24"	44 1/2"	120	1	60	12.7	20	1/3	3300
RBS033HV-62	38"	44 1/2"	120	1	60	12.7	20	1/3	3300
RBS034HV-62	50 1/2"	44 1/2"	120	1	60	19	25	1/2	5280



Please refer to our website to see our wide range of materials, finishes, merchandising foam, and accessories

*Dimensions are approximate and will vary based on wrap styles

LOW PROFILE REFRIGERATED SLANT CASES

AVAILABLE IN 6' - 12' LENGTHS



LOW PROFILE BACK REFRIGERATED SLANT CASES

DESCRIPTION

JSI's critical temp Refrigerated Slant Cases are available in our full range of styles and finish options to perfectly match your entire department.

BEST USED FOR:

- Front Entry
- Island Groupings
- Mix & Match with Refrigerated and Ambient Fixtures
- Berries

FEATURES



Electronic Controls

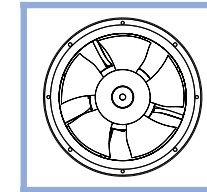

High-Efficiency Fan Motors

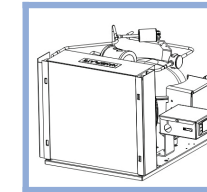

High-Efficiency Condensing Unit

STANDARD FEATURES

- High Efficiency Motors
- Digital Solar Thermometer
- Removable Service Panels
- Electronic Control
- Designed to Maintain Product Temperatures at <41°F
- Electric Condensate Pan

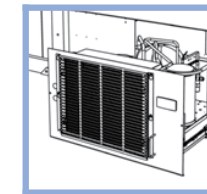

Slide-Out Service Drawer

OPTIONAL ACCESSORIES

- Merchandising Steps
- Various Shelf Styles and Sizes
- Corner Guards and Brackets
- Adjustable Wire Deck
- Foam Pad
- Price Tag Molding
- Magnetic Filter Screen
- Available in metal or wood wrap and in a variety of finishes

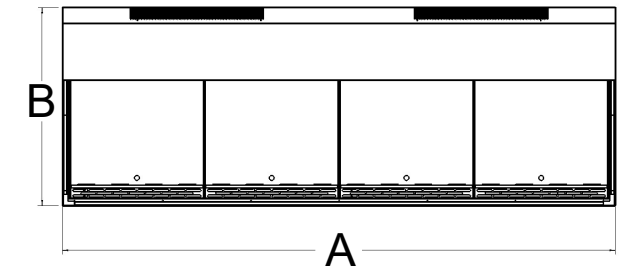
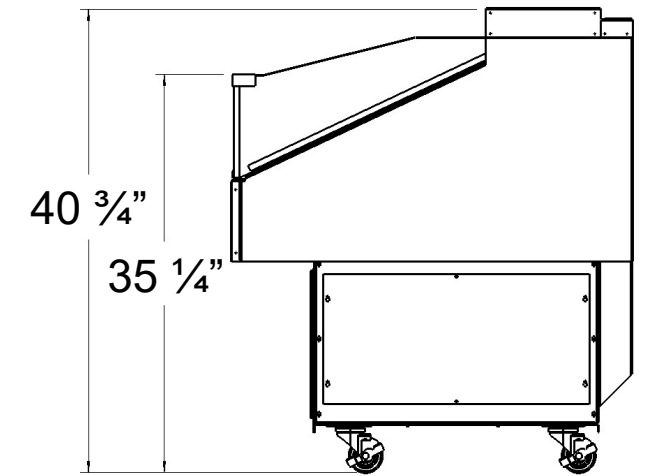

MODEL	DIMENSIONS*		POWER						
	A	B	V	Ph	Hz	MCA	MOP	HP	BTU/hr @ 75F
RBS036L	72"	36"	208	1	60	15.3	20	3/4	6390
RBS038L	96"	36"	208	1	60	18.5	25	1	9180
RBS0310L	120"	36"	208	1	60	21.3	25	1 1/4	11900
RBS0312L	144"	36"	208	1	60	21.4	25	1 1/4	11900
RBS046L	72"	48"	208	1	60	15.7	20	3/4	6090
RBS048L	96"	48"	208	1	60	18.5	25	1	8540

Please refer to our website to see our wide range of materials, finishes, merchandising foam, and accessories

*Dimensions are approximate and will vary based on wrap styles



HIGH PROFILE REFRIGERATED SLANT CASES

AVAILABLE IN 6' - 12' LENGTHS

Critical
TEMP



HIGH PROFILE REFRIGERATED SLANT CASES

DESCRIPTION

JSI's critical temp Refrigerated Slant Cases are available in our full range of styles and finish options to perfectly match your entire department.

BEST USED FOR:

- Front Entry
- Island Groupings
- Mix & Match with Refrigerated and Ambient Fixtures
- Berries

FEATURES



Electronic Controls

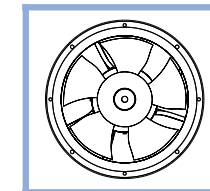

High-Efficiency Fan Motors

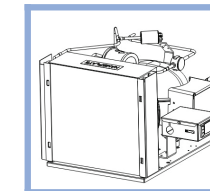

High-Efficiency Condensing Unit

STANDARD FEATURES

- High Efficiency Motors
- Digital Solar Thermometer
- Removable Service Panels
- Electronic Control
- Designed to Maintain Product Temperatures at <41°F
- Electric Condensate Pan

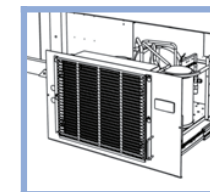

Slide-Out Service Drawer

OPTIONAL ACCESSORIES

- Merchandising Steps
- Various Shelf Styles and Sizes
- Corner Guards and Brackets
- Adjustable Wire Deck
- Foam Pad
- Price Tag Molding
- Magnetic Filter Screen
- Available in metal or wood wrap and in a variety of finishes
- Adjustable Metal Shelves

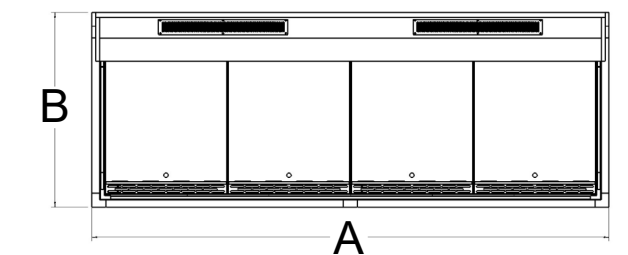
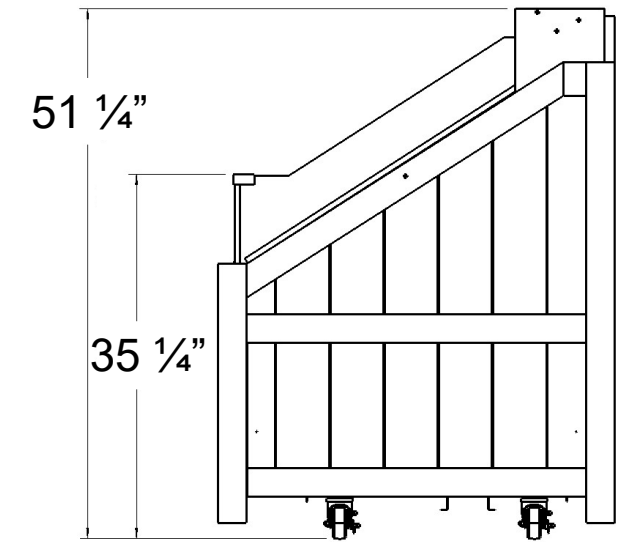

MODEL	DIMENSIONS*		POWER						
	A	B	V	Ph	Hz	MCA	MOP	HP	BTU/hr @ 75F
RBS036H	72"	36"	208	1	60	15.3	20	3/4	6390
RBS038H	96"	36"	208	1	60	18.5	25	1	9180
RBS0310H	120"	36"	208	1	60	21.3	25	1 1/4	11900
RBS0312H	144"	36"	208	1	60	23.3	30	1 1/4	11900
RBS046H	72"	48"	208	1	60	15.3	20	3/4	6390
RBS048H	96"	48"	208	1	60	18.5	25	1	9180

Please refer to our website to see our wide range of materials, finishes, merchandising foam, and accessories

*Dimensions are approximate and will vary based on wrap styles



41" HIGH VISIBILITY REFRIGERATED SLANT CASES

AVAILABLE IN 6' - 12' LENGTHS

Critical
TEMP



41" H HIGH-VISIBILITY REFRIGERATED SLANT CASES

DESCRIPTION

JSI's critical temp Refrigerated Slant Cases are available in our full range of styles and finish options to perfectly match your entire department. The low front design allows for maximum product visibility and a variety of merchandising options.

BEST USED FOR:

- Front Entry
- Island Groupings
- Mix & Match with Refrigerated and Ambient Fixtures
- Berries

FEATURES



Electronic Controls

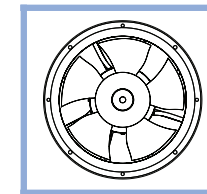

High-Efficiency Fan Motors

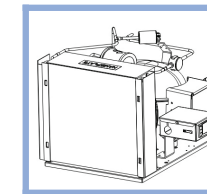

High-Efficiency Condensing Unit

STANDARD FEATURES

- High Efficiency Motors
- Digital Solar Thermometer
- Removable Service Panels
- Electronic Control
- Designed to Maintain Product Temperatures at <41°F
- Electric Condensate Pan

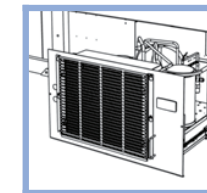

Slide-Out Service Drawer

OPTIONAL ACCESSORIES

- Merchandising Steps
- Various Shelf Styles and Sizes
- Corner Guards and Brackets
- Adjustable Wire Deck
- Foam Pad
- Price Tag Molding
- Magnetic Filter Screen
- Available in metal or wood wrap and in a variety of finishes
- Adjustable Metal Shelves

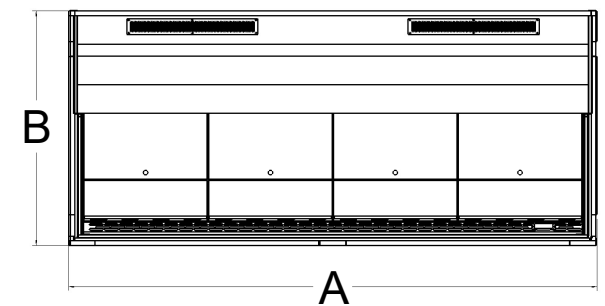
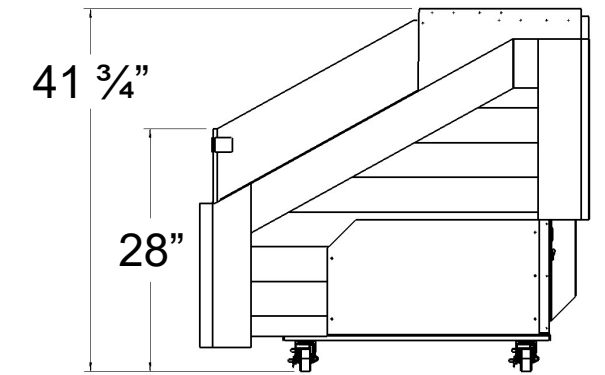

MODEL	DIMENSIONS*		POWER						
	A	B	V	Ph	Hz	MCA	MOP	HP	BTU/hr @ 75F
RBS036HV-41	74 1/2"	44 1/2"	208	1	60	15.3	20	3/4	7660
RBS038HV-41	101"	44 1/2"	208	1	60	18.5	25	1	9180
RBS0310HV-41	125 1/2"	44 1/2"	208	1	60	21.3	25	1 1/4	11900
RBS0312HV-41	149 1/2"	45"	208	1	60	23.3	30	1 1/4	11900



Please refer to our website to see our wide range of materials, finishes, merchandising foam, and accessories

*Dimensions are approximate and will vary based on wrap styles



49" HIGH VISIBILITY REFRIGERATED SLANT CASES

AVAILABLE IN 6' - 12' LENGTHS

Critical
TEMP



JSI Delivering a *fresh* experience
an  company

49" H HIGH-VISIBILITY REFRIGERATED SLANT CASES

DESCRIPTION

JSI's critical temp Refrigerated Slant Cases are available in our full range of styles and finish options to perfectly match your entire department. The low front design allows for maximum product visibility and a variety of merchandising options.

BEST USED FOR:

- Front Entry
- Island Groupings
- Mix & Match with Refrigerated and Ambient Fixtures
- Berries

FEATURES



Electronic Controls

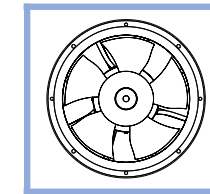

High-Efficiency Fan Motors

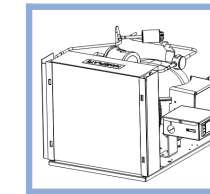

High-Efficiency Condensing Unit

STANDARD FEATURES

- High Efficiency Motors
- Digital Solar Thermometer
- Removable Service Panels
- Electronic Control
- Designed to Maintain Product Temperatures at <41°F
- Electric Condensate Pan

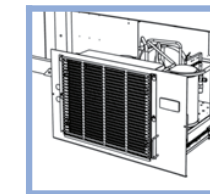

Slide-Out Service Drawer

OPTIONAL ACCESSORIES

- Merchandising Steps
- Various Shelf Styles and Sizes
- Corner Guards and Brackets
- Adjustable Wire Deck
- Foam Pad
- Price Tag Molding
- Magnetic Filter Screen
- Available in metal or wood wrap and in a variety of finishes
- Adjustable Metal Shelves

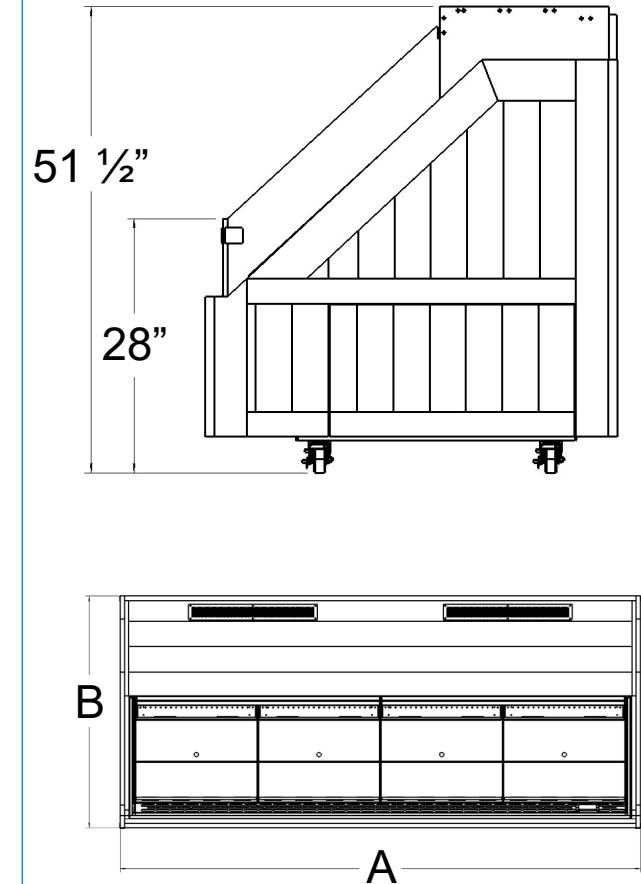

MODEL	DIMENSIONS*		POWER						
	A	B	V	Ph	Hz	MCA	MOP	HP	BTU/hr @ 75F
RBS036HV-49	74 1/2"	44 1/2"	208	1	60	15.3	20	3/4	7660
RBS038HV-49	101"	44 1/2"	208	1	60	18.5	25	1	9180
RBS0310HV-49	125 1/2"	44 1/2"	208	1	60	21.3	25	1 1/4	11900
RBS0312HV-49	149 1/2"	45"	208	1	60	23.3	30	1 1/4	11900



Please refer to our website to see our wide range of materials, finishes, merchandising foam, and accessories

*Dimensions are approximate and will vary based on wrap styles

56" HIGH VISIBILITY REFRIGERATED SLANT CASES

AVAILABLE IN 6' - 10' LENGTHS

Critical
TEMP



56" H HIGH-VISIBILITY REFRIGERATED SLANT CASES

DESCRIPTION

JSI's critical temp Refrigerated Slant Cases are available in our full range of styles and finish options to perfectly match your entire department. The low front design allows for maximum product visibility and a variety of merchandising options.

BEST USED FOR:

- Front Entry
- Island Groupings
- Mix & Match with Refrigerated and Ambient Fixtures
- Berries

FEATURES



Electronic Controls

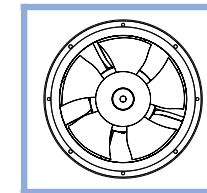

High-Efficiency Fan Motors

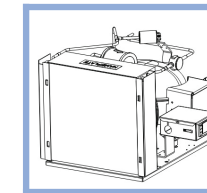

High-Efficiency Condensing Unit

STANDARD FEATURES

- High Efficiency Motors
- Digital Solar Thermometer
- Removable Service Panels
- Electronic Control
- Designed to Maintain Product Temperatures at <41°F
- Electric Condensate Pan

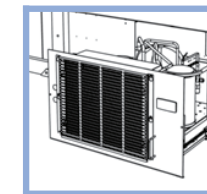

Slide-Out Service Drawer

OPTIONAL ACCESSORIES

- Merchandising Steps
- Various Shelf Styles and Sizes
- Corner Guards and Brackets
- Adjustable Wire Deck
- Foam Pad
- Price Tag Molding
- Magnetic Filter Screen
- Available in metal or wood wrap and in a variety of finishes
- Adjustable Metal Shelves

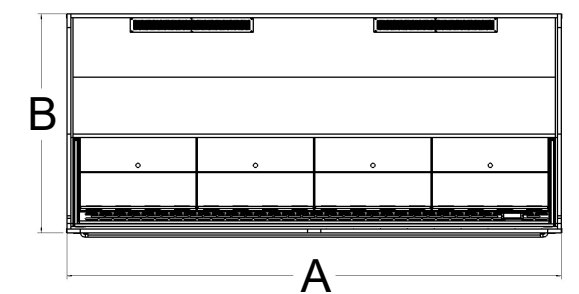
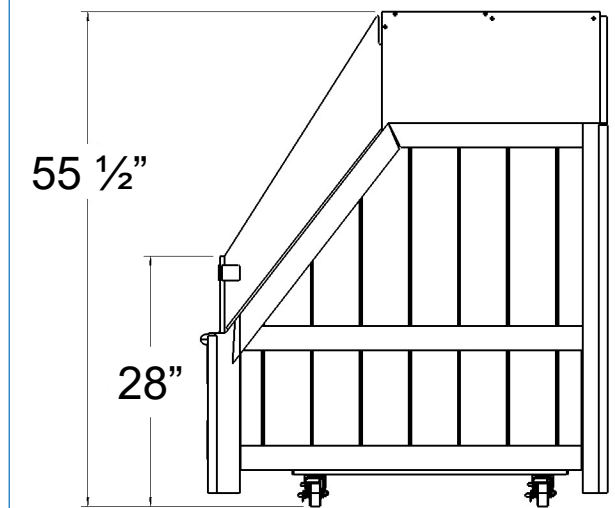

MODEL	DIMENSIONS*		POWER						
	A	B	V	Ph	Hz	MCA	MOP	HP	BTU/hr @ 75F
RBS036HV-56	74 1/2"	44 1/2"	208	1	60	15.3	20	3/4	7660
RBS038HV-56	101"	44 1/2"	208	1	60	18.5	25	1	9180
RBS0310HV-56	125 1/2"	44 1/2"	208	1	60	21.3	25	1 1/4	11900



Please refer to our website to see our wide range of materials, finishes, merchandising foam, and accessories

*Dimensions are approximate and will vary based on wrap styles

62" HIGH VISIBILITY REFRIGERATED SLANT CASES

AVAILABLE IN 6' - 10' LENGTHS

Critical
TEMP

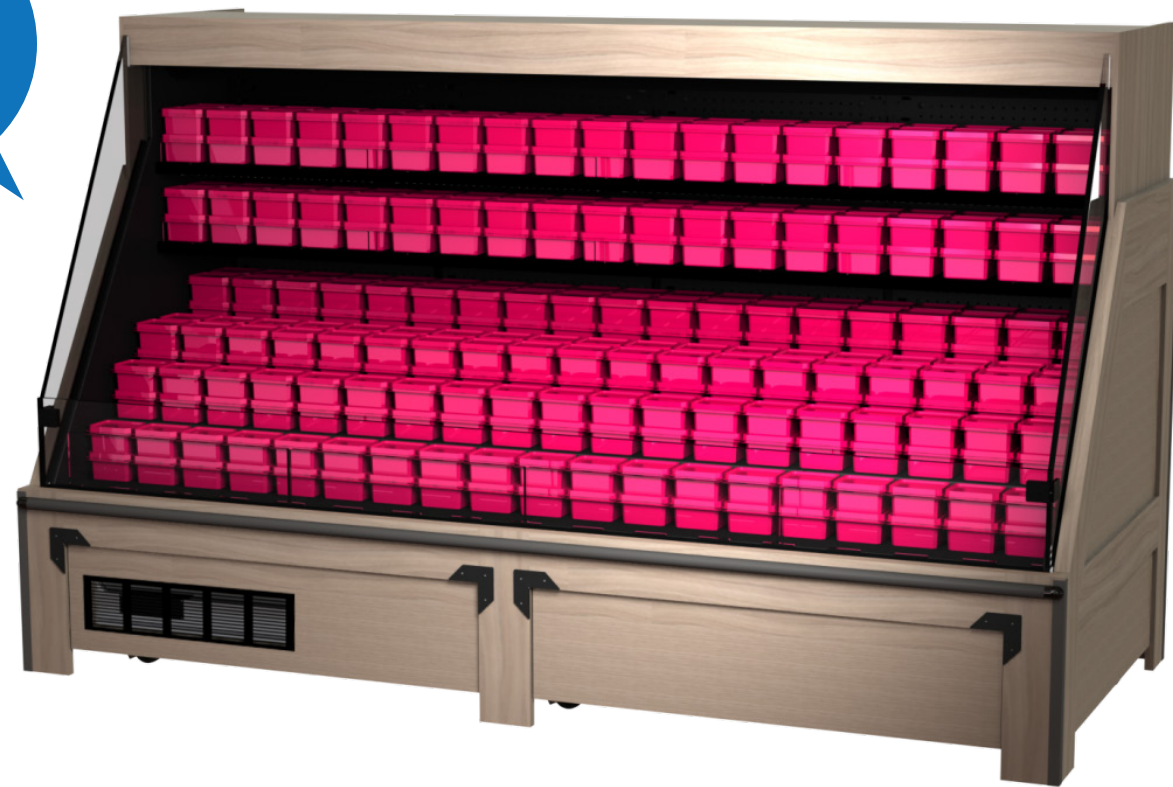

62" H HIGH-VISIBILITY REFRIGERATED SLANT CASES

DESCRIPTION

JSI's critical temp Refrigerated Slant Cases are available in our full range of styles and finish options to perfectly match your entire department. The low front design allows for maximum product visibility and a variety of merchandising options.

BEST USED FOR:

- Front Entry
- Island Groupings
- Mix & Match with Refrigerated and Ambient Fixtures
- Berries

FEATURES



Electronic Controls

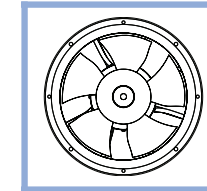

High-Efficiency Fan Motors

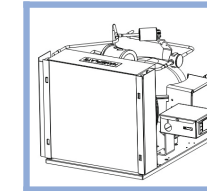

High-Efficiency Condensing Unit

STANDARD FEATURES

- High Efficiency Motors
- Digital Solar Thermometer
- Removable Service Panels
- Electronic Control
- Designed to Maintain Product Temperatures at <41°F
- Electric Condensate Pan

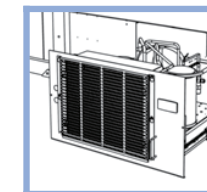

Slide-Out Service Drawer

OPTIONAL ACCESSORIES

- Merchandising Steps
- Various Shelf Styles and Sizes
- Corner Guards and Brackets
- Adjustable Wire Deck
- Foam Pad
- Price Tag Molding
- Magnetic Filter Screen
- Available in metal or wood wrap and in a variety of finishes
- Adjustable Metal Shelves

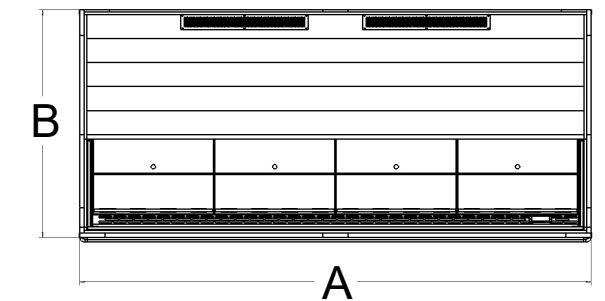
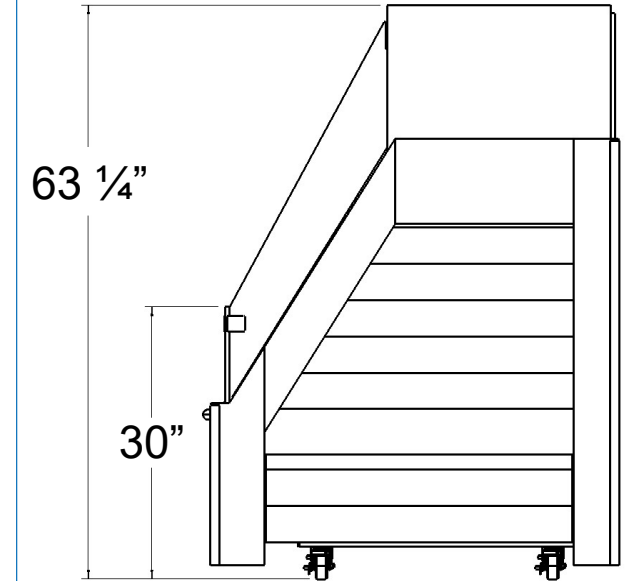

MODEL	DIMENSIONS*		POWER							
	A	B	V	Ph	Hz	MCA	MOP	HP	BTU/hr @ 75F	
RBS036HV-62	74 1/2"	44 1/2"	208	1	60	15.3	20	3/4	7660	
RBS038HV-62	101"	44 1/2"	208	1	60	18.5	25	1	9180	
RBS0310HV-62	125 1/2"	44 1/2"	208	1	60	21.3	25	1 1/4	11900	



Please refer to our website to see our wide range of materials, finishes, merchandising foam, and accessories

*Dimensions are approximate and will vary based on wrap styles



49" HIGH-VISIBILITY SELF CONTAINED REFRIGERATED UPRIGHT CASES

AVAILABLE IN 6' - 12' LENGTHS

Critical
TEMP



49" HIGH-VISIBILITY REFRIGERATED UPRIGHT CASES

DESCRIPTION

JSI's critical temp Refrigerated Upright Cases are available in our full range of styles and finish options to perfectly match your entire department. The low front design allows for maximum product visibility and a variety of merchandising options.

BEST USED FOR

- Front Entry
- Island Groupings
- Mix & Match with Refrigerated and Ambient Fixtures
- Berries

FEATURES

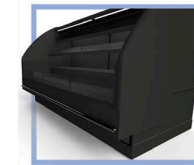

LOW 16" DECK HEIGHT

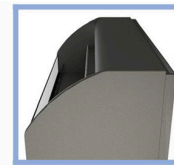

SLEEK, CURVED SIDES AND HOOD

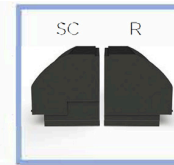

SAME PROFILE, SELF CONTAINED OR REMOTE

STANDARD FEATURES

- High Efficiency Motors
- Digital Solar Thermometer
- Removable Service Panels
- Electronic Control
- Designed to Maintain Product Temperatures at <41° F
- Electric Condensate Pan

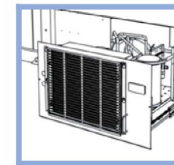

SLIDE-OUT SERVICE DRAWER

OPTIONAL ACCESSORIES

- Metal Toe kicks
- 12", 15", and 17" deep LED lit Shelves
- Corner Guards and Bumper
- Adjustable Wire Deck
- Foam Pad
- Price Tag Molding
- Magnetic Filter Screen
- Available in many laminates, or with front accent trim.

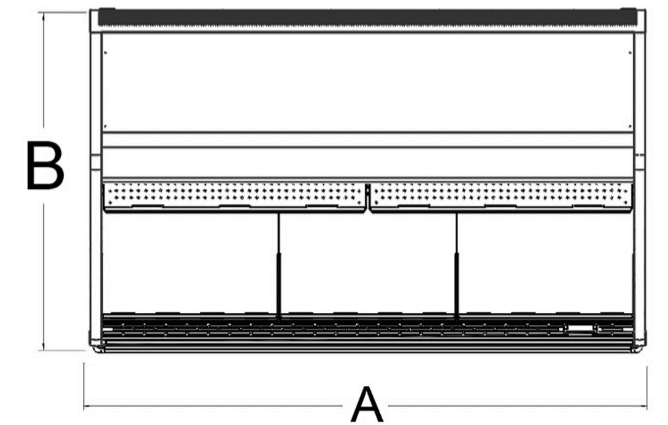
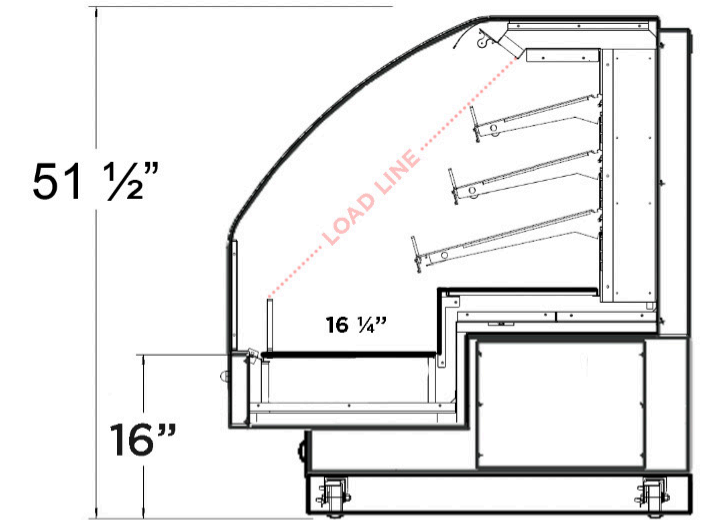

MODEL	DIMENSIONS*		POWER						
	A	B	V	Ph	Hz	MCA	MOP	HP	BTU/hr @ 75F
RBS046HVB-49	75 1/2"	45 1/2"	208	1	60	15.3	20	3/4	7660
RBS048HVB-49	99"	45 1/2"	208	1	60	18.5	25	1	9180
RBS0410HVB-49	123"	45 1/2"	208	1	60	21.3	25	1 1/4	11900
RBS0412HVB-49	147"	45 1/2"	208	1	60	23.3	30	1 1/4	11900



Please refer to our website to see our wide range of materials, finishes, merchandising foam, and accessories

*Dimensions are approximate and will vary based on wrap styles

49" HIGH-VISIBILITY REMOTE REFRIGERATED UPRIGHT CASES

AVAILABLE IN 6' - 12' LENGTHS

Critical
TEMP



49" HIGH-VISIBILITY REFRIGERATED UPRIGHT CASES

DESCRIPTION

JSI's critical temp Refrigerated Upright Cases are available in our full range of styles and finish options to perfectly match your entire department. The low front design allows for maximum product visibility and a variety of merchandising options.

BEST USED FOR

- Front Entry
- Island Groupings
- Mix & Match with Refrigerated and Ambient Fixtures
- Berries

FEATURES

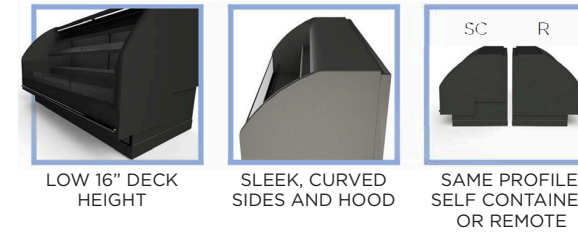

STANDARD FEATURES

- High Efficiency Motors
- Digital Solar Thermometer
- Removable Service Panels
- Electronic Control
- Designed to Maintain Product Temperatures at <41° F
- Electric Condensate Pan

OPTIONAL ACCESSORIES

- Metal Toe kicks
- 12", 15", and 17" deep LED lit Shelves
- Corner Guards and Bumper
- Adjustable Wire Deck
- Foam Pad
- Price Tag Molding
- Magnetic Filter Screen
- Available in many laminates, or with front accent trim.

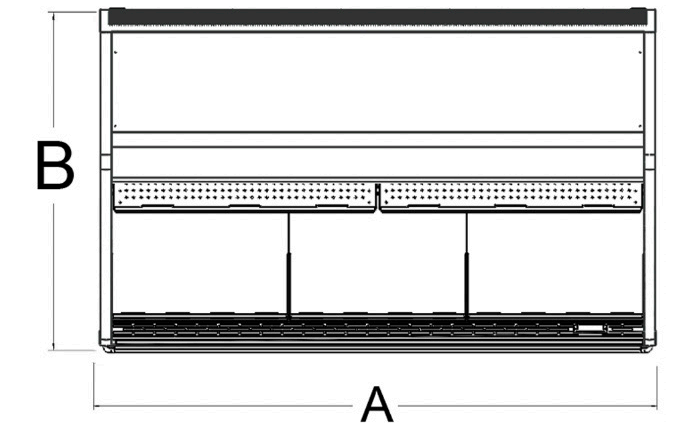
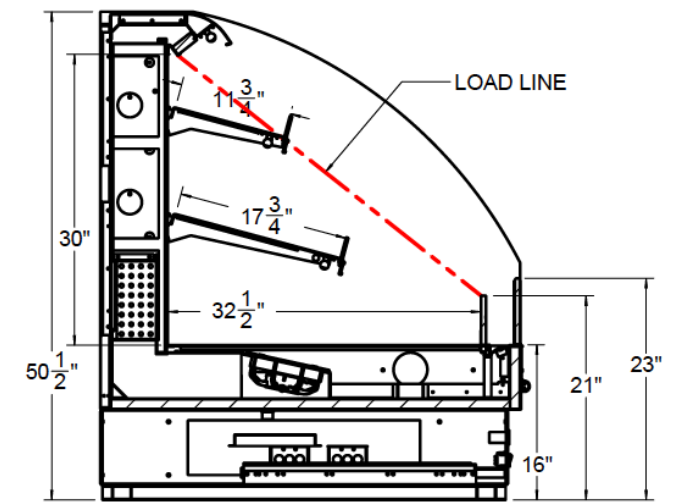

MODEL	DIMENSIONS*		POWER						
	A	B	V	Ph	Hz	MCA	MOP	HP	BTU/hr @ 75F
RBS146HVB-49	75 1/2"	45 1/2"	208	1	60	15.3	20	3/4	7660
RBS148HVB-49	99"	45 1/2"	208	1	60	18.5	25	1	9180
RBS1410HVB-49	123"	45 1/2"	208	1	60	21.3	25	1 1/4	11900
RBS1412HVB-49	147"	45 1/2"	208	1	60	23.3	30	1 1/4	11900



Please refer to our website to see our wide range of materials, finishes, merchandising foam, and accessories

*Dimensions are approximate and will vary based on wrap styles

55" HIGH REFRIGERATED MULTI DECKS

Critical
TEMP



55" HIGH REFRIGERATED MULTI DECKS

DESCRIPTION

JSI's critical temp Refrigerated Multi Decks are available in our full range of styles and finish options to perfectly match your entire department.

BEST USED FOR:

- Spot Merchandising
- End Caps
- Island Groupings
- Mix & Match with Refrigerated and Ambient Fixtures

FEATURES



Electronic Controls

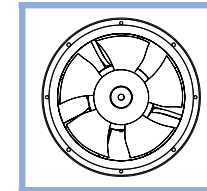

High-Efficiency Fan Motors

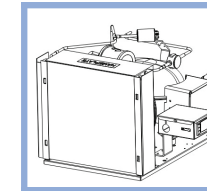

High-Efficiency Condensing Unit

STANDARD FEATURES

- High Efficiency Motors
- Digital Solar Thermometer
- Removable Service Panels
- Electronic Control
- Designed to Maintain Product Temperatures at <41°F
- 2 Standard 15" or 17" Shelves

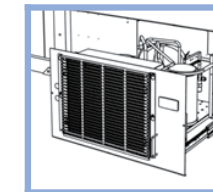

Slide-Out Service Drawer

OPTIONAL ACCESSORIES

- LED Lighting
- Price Tag Molding
- Shelf Product Stop
- Various Shelf Sizes

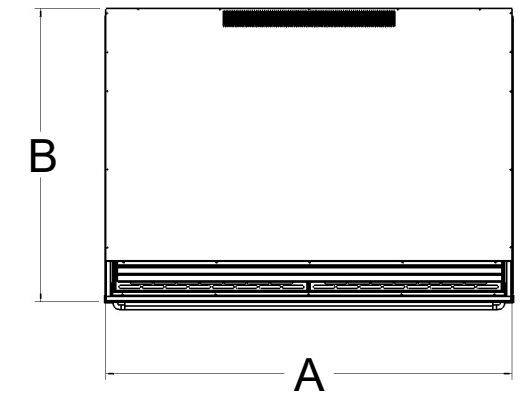
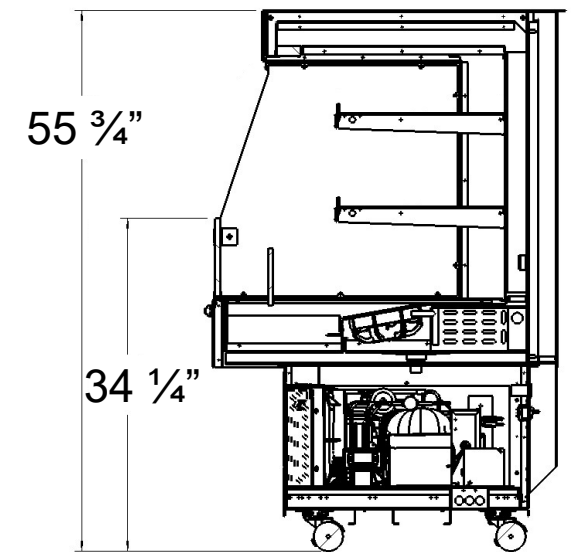

SECTION VIEW DENOTES STANDARD CASE OFFERING

MODEL	DIMENSIONS*		POWER						
	A	B	V	Ph	Hz	MCA	MOP	HP	BTU/hr @ 75F
RMD022-55	24"	24"	120	1	60	12.5	20	1/3	2920
RMD023-55	36"	24"	120	1	60	22.4	25	1/2	4750
RMD024-55	48"	24"	120	1	60	23.7	30	1/2	4750
RMD026-55	72"	24"	208	1	60	15.76	20	3/4	7660
RMD028-55	96"	24"	208	1	60	21.3	25	1	9180
RMD032-55	24"	36"	120	1	60	17.8	20	1/3	2920
RMD033-55	36"	36"	120	1	60	22.4	25	1/2	4750
RMD034-55	48"	36"	208	1	60	15.8	20	3/4	6090

Please refer to our website to see our wide range of materials, finishes, merchandising foam, and accessories

*Dimensions are approximate and will vary based on wrap styles



62" HIGH REFRIGERATED MULTI DECKS

Critical
TEMP



JSI Delivering a *fresh* experience
an  company

62" HIGH REFRIGERATED MULTI DECKS

DESCRIPTION

JSI's critical temp Refrigerated Multi Decks are available in our full range of styles and finish options to perfectly match your entire department.

BEST USED FOR:

- Spot Merchandising
- End Caps
- Island Groupings
- Mix & Match with Refrigerated and Ambient Fixtures

FEATURES



Electronic Controls

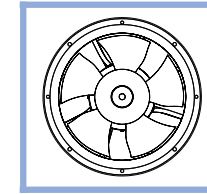

High-Efficiency Fan Motors

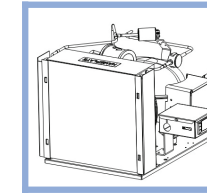

High-Efficiency Condensing Unit

STANDARD FEATURES

- High Efficiency Motors
- Digital Solar Thermometer
- Removable Service Panels
- Electronic Control
- Designed to Maintain Product Temperatures at <41°F
- 2 Standard 15" or 17" Shelves

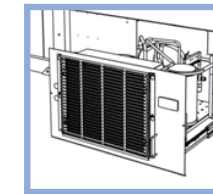

Slide-Out Service Drawer

OPTIONAL ACCESSORIES

- LED Lighting
- Price Tag Molding
- Shelf Product Stop
- Various Shelf Sizes

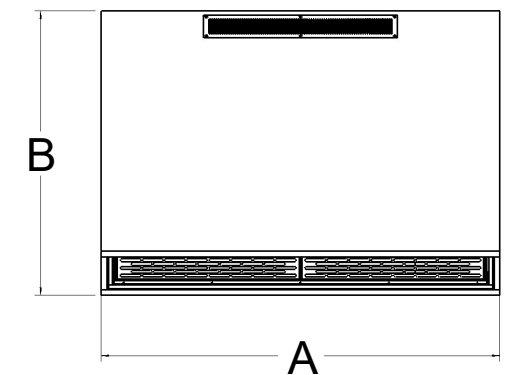
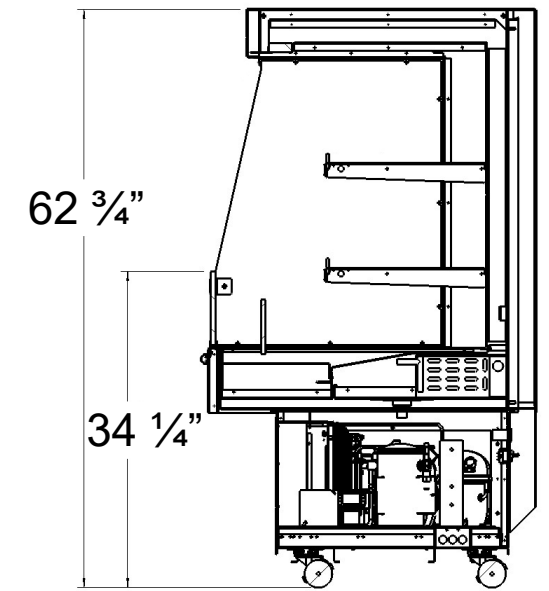

SECTION VIEW DENOTES STANDARD CASE OFFERING

MODEL	DIMENSIONS*		POWER						
	A	B	V	Ph	Hz	MCA	MOP	HP	BTU/hr @ 75F
RMD022-62	24"	24"	120	1	60	17.1	20	1/2	4750
RMD023-62	36"	24"	120	1	60	26	30	3/4	6090
RMD024-62	48"	24"	120	1	60	15.8	20	3/4	6090
RMD026-62	72"	24"	208	1	60	16.78	25	1	9180
RMD028-62	96"	24"	208	1	60	17.56	30	1 1/4	11900
RMD032-62	24"	36"	120	1	60	22.4	30	1/2	4750
RMD033-62	36"	36"	208	1	60	15.6	20	3/4	6090
RMD034-62	48"	36"	208	1	60	15.8	20	3/4	6090

Please refer to our website to see our wide range of materials, finishes, merchandising foam, and accessories

*Dimensions are approximate and will vary based on wrap styles



72" HIGH REFRIGERATED MULTI DECKS

Critical
TEMP



JSI Delivering a *fresh* experience
an  company

72" HIGH REFRIGERATED MULTI DECKS

DESCRIPTION

JSI's critical temp Refrigerated Multi Decks are available in our full range of styles and finish options to perfectly match your entire department.

BEST USED FOR:

- Spot Merchandising
- End Caps
- Island Groupings
- Mix & Match with Refrigerated and Ambient Fixtures

FEATURES



Electronic Controls

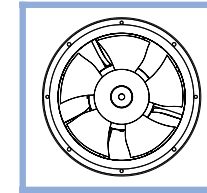

High-Efficiency Fan Motors

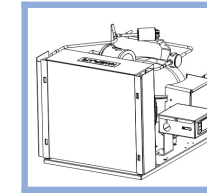

High-Efficiency Condensing Unit

STANDARD FEATURES

- High Efficiency Motors
- Digital Solar Thermometer
- Removable Service Panels
- Electronic Control
- Designed to Maintain Product Temperatures at <41°F
- 2 Standard 15" or 17" Shelves

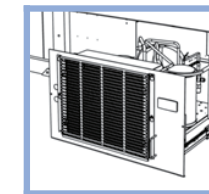

Slide-Out Service Drawer

OPTIONAL ACCESSORIES

- LED Lighting
- Price Tag Molding
- Shelf Product Stop
- Various Shelf Sizes

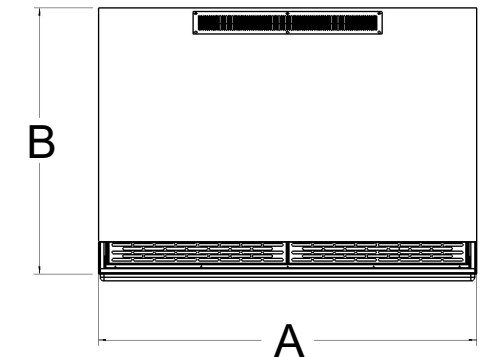
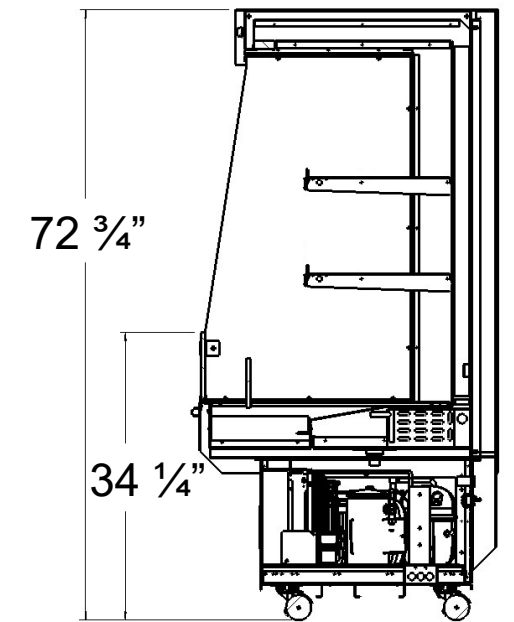

SECTION VIEW DENOTES STANDARD CASE OFFERING

MODEL	DIMENSIONS*		POWER						
	A	B	V	Ph	Hz	MCA	MOP	HP	BTU/hr @ 75F
RMD022-72	24"	24"	120	1	60	17.1	20	1/2	4750
RMD023-72	36"	24"	208	1	60	18.7	20	1	8540
RMD024-72	48"	24"	208	1	60	17.7	20	1	8540
RMD032-72	24"	36"	120	1	60	15.6	20	3/4	6090
RMD033-72	36"	36"	208	1	60	18.7	20	1	8540
RMD034-72	48"	36"	208	1	60	17.7	20	1	8540



Please refer to our website to see our wide range of materials, finishes, merchandising foam, and accessories

*Dimensions are approximate and will vary based on wrap styles

84" HIGH REFRIGERATED MULTI DECKS

Critical
TEMP



JSI
an  company

Delivering a
fresh experience

84" HIGH REFRIGERATED MULTI DECKS

DESCRIPTION

JSI's critical temp Refrigerated Multi Decks are available in our full range of styles and finish options to perfectly match your entire department.

BEST USED FOR:

- Spot Merchandising
- End Caps
- Island Groupings
- Mix & Match with Refrigerated and Ambient Fixtures

FEATURES



Electronic Controls

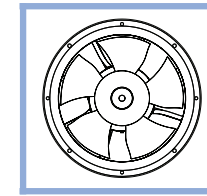

High-Efficiency Fan Motors

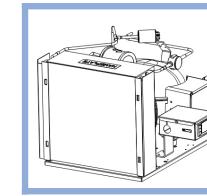

High-Efficiency Condensing Unit

STANDARD FEATURES

- High Efficiency Motors
- Digital Solar Thermometer
- Removable Service Panels
- Electronic Control
- Designed to Maintain Product Temperatures at <41°F
- 3 Standard 15" or 17" Shelves

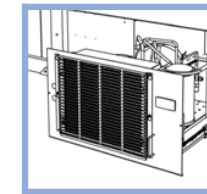

Slide-Out Service Drawer

OPTIONAL ACCESSORIES

- LED Lighting
- Price Tag Molding
- Shelf Product Stop
- Various Shelf Sizes

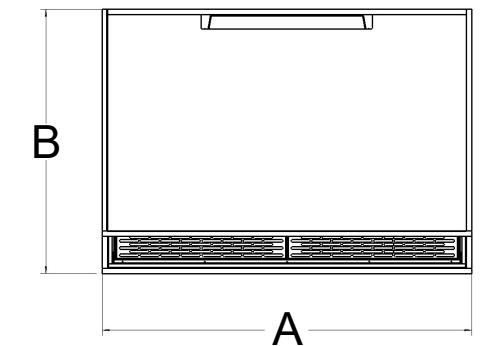
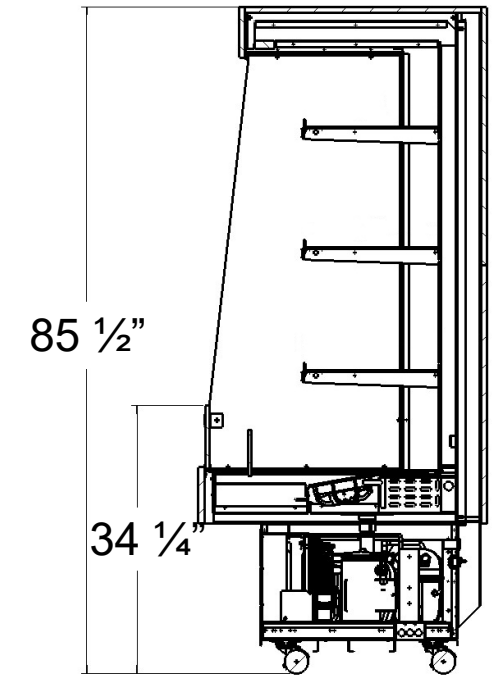

SECTION VIEW DENOTES STANDARD CASE OFFERING

MODEL	DIMENSIONS*		POWER						
	A	B	V	Ph	Hz	MCA	MOP	HP	BTU/hr @ 75F
RMD022-84	24"	24"	110	1	60	20.5	30	½	4750
RMD023-84	36"	24"	220	1	60	16	25	1	8540
RMD024-84	48"	24"	220	1	60	15.5	30	¾	6090
RMD032-84	24"	36"	120	1	60	20.5	30	½	4750
RMD033-84	36"	36"	208	1	60	16	25	1	8540
RMD034-84	48"	36"	208	1	60	17.7	20	1	8540



Please refer to our website to see our wide range of materials, finishes, merchandising foam, and accessories

*Dimensions are approximate and will vary based on wrap styles

84" HIGH SLIM REFRIGERATED MULTI DECKS

24" OUTSIDE DEPTH

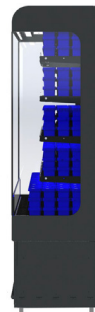

ARGON FILLED GLASS SIDES

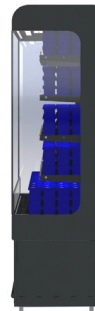

ACRYLIC SIDES



WOOD LAMINATED SIDES

JSI Delivering a *fresh* experience
an  company

84" HIGH SLIM REFRIGERATED MULTI DECK

DESCRIPTION

Our new refrigerated line of slim multi deck merchandisers can do it all! Place one in aisle with existing shelving or as a spot merchandiser for beverages. JSI offers 3 styles per size, creating plenty of configuration options.

BEST USED FOR

- In-Aisle Refrigeration
- Spot Merchandising
- Wine/Beverage
- Prepackaged meals

FEATURES

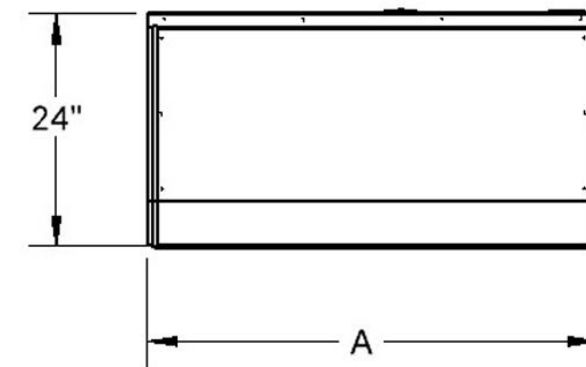

STANDARD FEATURES

- High Efficiency Motors
- Digital Solar Thermometer
- Removable Service Panels
- Electronic Control
- Designed to Maintain Product
- Temperatures at <41 F
- Electric Condensate Pan
- Laminated side panels
- 4 Standard 12" or 15" Shelves
- 12" Maximum Shelf Depth

OPTIONAL ACCESSORIES

- LED lighting
- Custom Wood accent piece
- Clear Acrylic sides
- Clear Argon filled glass sides

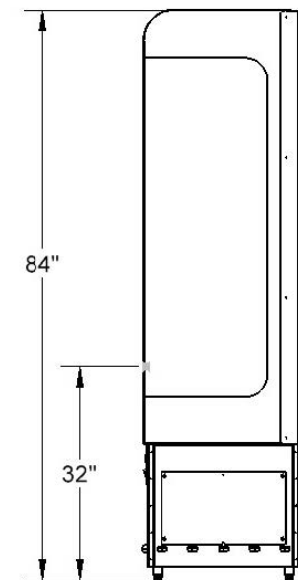

MODEL	DIMENSIONS*		POWER						
	A	B	V	Ph	Hz	MCA	MOP	HP	BTU/hr @ 75F
RMD022S-84	23 1/2"	24"	110	1	60	20.5	30	1/2	4750
RMD023S-84	35 1/2"	24"	220	1	60	15.5	30	3/4	6090
RMD024S-84	47 1/2"	24"	220	1	60	16	25	1	8540



Please refer to our website to see our wide range of materials, finishes, merchandising foam, and accessories

*Dimensions are approximate and will vary based on wrap styles

To learn more about how JSI can provide the perfect solution for you, contact us:



Call **800.332.5507**



Email **info@jsistorefixtures.com**

OUR LOCATIONS



140 Park Street • Milo, Maine 04463 • 800.332.5507 TEL • 207.943.5632 FAX • **JSISTOREFIXTURES.COM**
Milo, Maine • Bangor, Maine • Payson, Utah • Collingwood, Ontario