

CONVENIENCE MERCHANDISERS QUICK VIEW



WHY JSI?

TABLE OF CONTENTS

We bring unequaled scale, scope, and customer service, as well as a guiding belief that our retail partners are not just buying a fixture - they are investing in a long-term vision of success.



Massive portfolio of displays for every department in your store



We make custom standard, so your store is designed your way

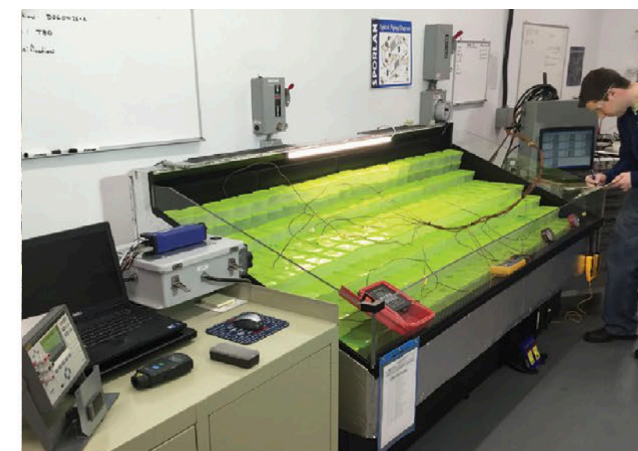

No spot checks—every unit is tested to ensure business continuity



Regional distribution, national reach

WHY JSI?

3

LSI CAPABILITIES

4

HOW CAN JSI HELP YOU?

5

MILLWORK

6

REFRIGERATION

7

PRODUCE

24

BAKERY

26

PROMO TABLES

28

CONFIGURATIONS

30

JSI & LSI, THE PERFECT FIT FOR YOUR STORE

For over 50 years, our parent company, LSI Industries, has been the indisputable leader in providing innovative lighting and graphic solutions to the retail petroleum/c-store & petroleum fleet market. With JSI and LSI, the possibilities are endless!



ACM Fascia
Printed Graphics

Undercanopy LED
Fixtures

Archer™
LED Illumination

Metal Flag Signs
Powder-coated
Printed Graphics

3D Metal
Formed
Valance

Metal Door
Powder-coated
Printed Graphics

Dispenser Graphics
Branded Overlays
Regulatory Decals

Metal Risers

Additional LSI Services Include:



Menu Boards



Monitors



Interior Decor

HOW CAN JSI HELP YOU?



Refrigeration

JSI brings you the latest innovations in refrigerated display cases, turning ordinary refrigerated cases into convenience store merchandising display powerhouses.

We make custom standard. From Multi-Level refrigerated cases to low profile slant bins—our customizable solutions are all designed to maintain critical temperatures to keep your fruits fresh, veggies vibrant, and prepared foods perfect.



Bakery

Showcase your baked goods while keeping them at their freshest with JSI pastry cases, tables and refrigerated units. JSI has a wide range of display cases to support your fresh baked program and display tables for your bakery package program. Our fixtures create a cohesive impression and display your products beautifully.



Millwork/Specialty

Create a unique ambiance for coffee stations, growler bars, service bars, and more with JSI. Building on-site can be expensive and time consuming. JSI can save you time and money by designing and providing stunning fixtures for your store's services.



LSI

Our partnership with LSI makes us an all-in-one solution for Convenience. LSI provides high-performance, American-made lighting, decor and graphics solutions that will bring your space to life. From interior and exterior lighting to menu boards and monitors, LSI can make it happen!

CUSTOM MILLWORK SOLUTIONS



JSI offers a wide range of millwork solutions that can be customized to fit any space. We partner with our customers to design, manufacture and deliver great solutions on time for their customers and employees.

Whether it's a single fixture or complete store remodel, we've got you covered!



KEEP IT COOL WITH JSI REFRIGERATION

We offer a large selection of self-contained, remote and type 2 certified refrigerated fixtures.



Self-Contained

Self-contained refrigerated fixtures can be placed in a variety of areas throughout the store creating merchandise power houses to enhance your customer's experience.



Remote

Our remote refrigerated fixtures are designed to easily tie into your existing system adding a fresh new look to any location.



Type 2 Certified

Type 2 certification gives you the confidence that our merchandise power houses will keep your product fresh all the time.

JSI has what you need when it comes to refrigeration. With fully customizable fresh to go islands and slant cases you can be sure your next solution will deliver results.

V-SERIES REMOTE REFRIGERATED CASES

V-SERIES REMOTE REFRIGERATED CASE

CRITICAL TEMP



DESCRIPTION

Our V-Series refrigerated display cases bring added value to any program and are available in metal finishes.

BEST USED FOR

- Spot Merchandising
- Promotional displays
- Convenience stores
- Prepackaged meals

FEATURES

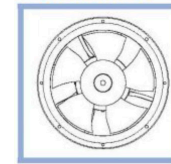

HIGH-EFFICIENCY MOTORS

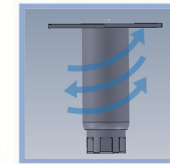

ADJUSTABLE LEVELERS



MAINTAINS CRITICAL TEMPERATURE

STANDARD FEATURES

- High Efficiency Motors
- High Efficiency Condensing Unit
- Removable Service Panels
- Electronic Control
- Designed to Maintain Product Temperatures at <math><41^{\circ}</math> F
- Electric Condensate Pan

OPTIONAL ACCESSORIES

- Corner Guards
- Corner Brackets
- Black Bumper
- Various Product Risers
- Magnetic Filter Screen
- 12" Adjustable Metal Shelf

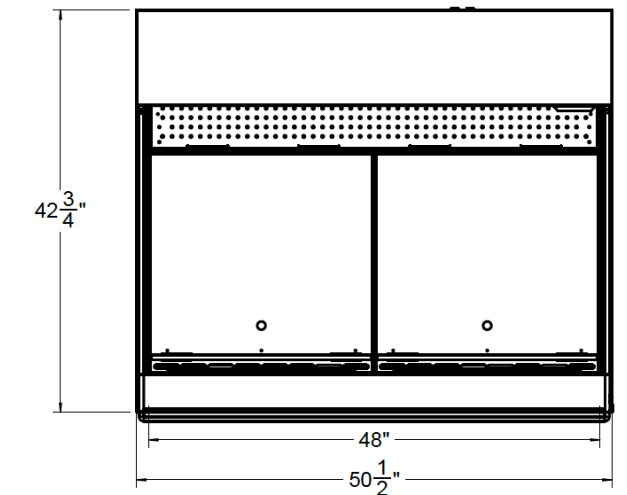
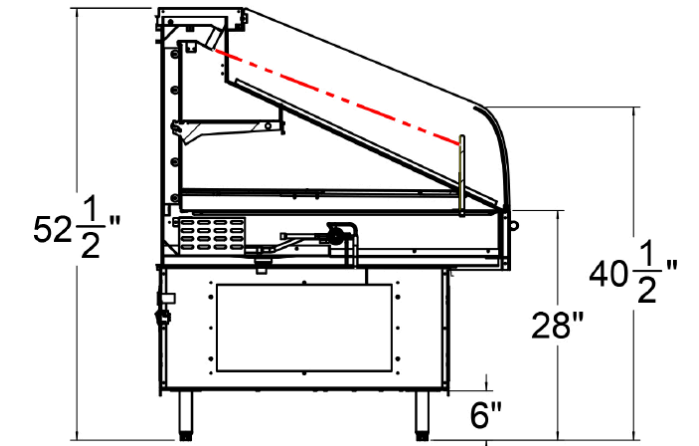

MODEL	DIMENSIONS*		POWER						
	A	B	V	Ph	Hz	MCA	MOP	HP	BTU/hr @ 75F
RBS146H	52 1/2"	45 3/4"	-	-	-	-	-	1/2	-



Please refer to our website to see our wide range of materials, finishes, merchandising foam, and accessories

*Dimensions are approximate and will vary based on wrap styles



V-SERIES SELF-CONTAINED REFRIGERATED CASES

CRITICAL
TEMP



V-SERIES SELF-CONTAINED REFRIGERATED CASE

DESCRIPTION

Our V-Series refrigerated display cases bring added value to any program and are available in metal finishes.

BEST USED FOR

- Spot Merchandising
- Promotional displays
- Convenience stores
- Prepackaged meals

FEATURES

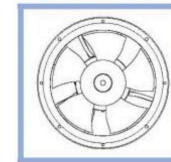

HIGH EFFICIENCY MOTORS

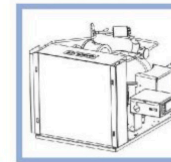

HIGH EFFICIENCY CONDENSING UNIT



MAINTAINS CRITICAL TEMPERATURE

STANDARD FEATURES

- High Efficiency Motors
- High Efficiency Condensing Unit
- Removable Service Panels
- Electronic Control
- Designed to Maintain Product Temperatures at <math><41^{\circ}</math> F
- Electric Condensate Pan

OPTIONAL ACCESSORIES

- Corner Guards
- Corner Brackets
- Black Bumper
- Various Product Risers
- Magnetic Filter Screen
- 12" Adjustable Metal Shelf

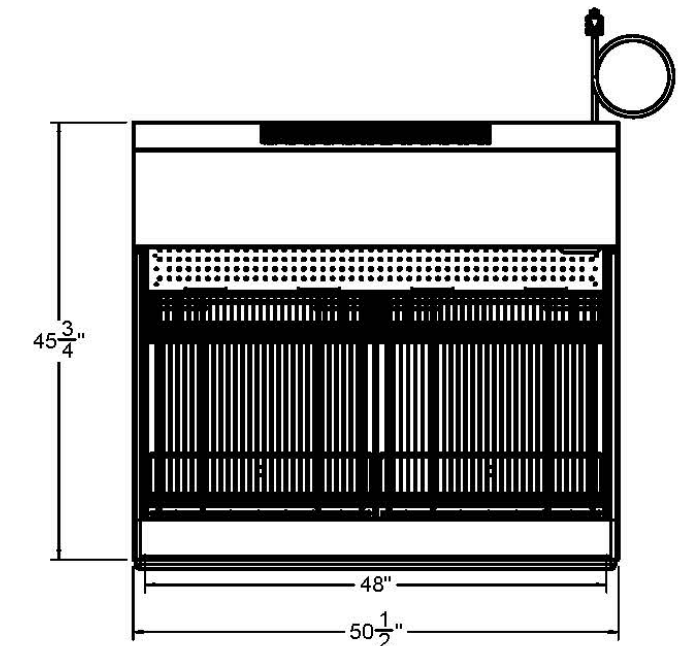
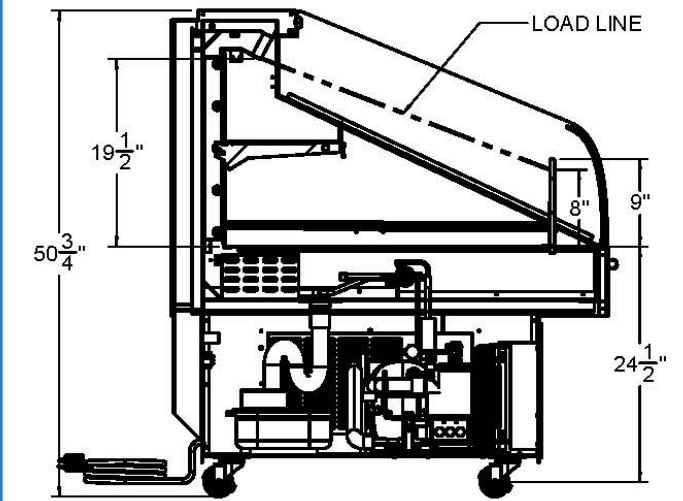

MODEL	DIMENSIONS*		POWER						
	A	B	V	Ph	Hz	MCA	MOP	HP	BTU/hr @ 75F
RBS046H	50 3/4"	45 3/4"	120	1	60	18.2	25	1/2	4750



Please refer to our website to see our wide range of materials, finishes, merchandising foam, and accessories

*Dimensions are approximate and will vary based on wrap styles

HIGH PROFILE REFRIGERATED SLANT CASES

Critical
TEMP



HIGH PROFILE REFRIGERATED SLANT CASES

DESCRIPTION

JSI's critical temp Refrigerated Slant Cases are available in our full range of styles and finish options to perfectly match your entire department.

BEST USED FOR:

- Spot Merchandising
- Front Entry
- Mix & Match with Refrigerated and Ambient Fixtures
- Critical Temp Product

FEATURES



Electronic Controls

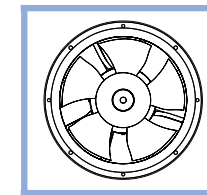

High-Efficiency Fan Motors

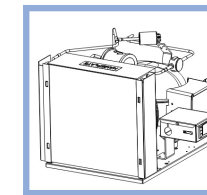

High-Efficiency Condensing Unit

STANDARD FEATURES

- High Efficiency Motors
- Digital Solar Thermometer
- Removable Service Panels
- Electronic Control
- Designed to Maintain Product Temperatures at <41°F
- Electric Condensate Pan

OPTIONAL ACCESSORIES

- Merchandising Steps
- Various Shelf Styles and Sizes
- Corner Guards and Brackets
- Adjustable Wire Deck
- Foam Pad
- Price Tag Molding
- Magnetic Filter Screen
- Available in metal or wood wrap and in a variety of finishes

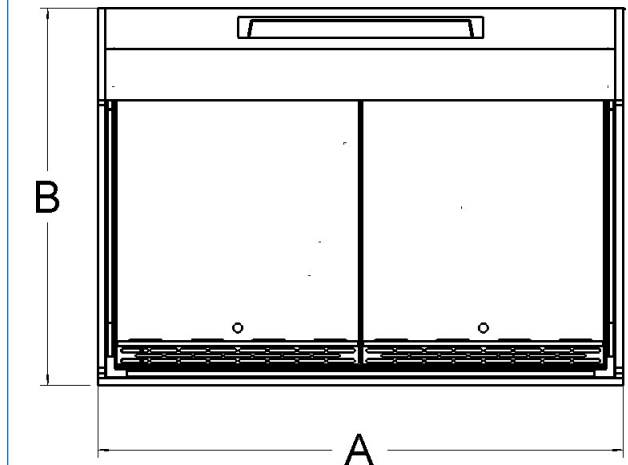
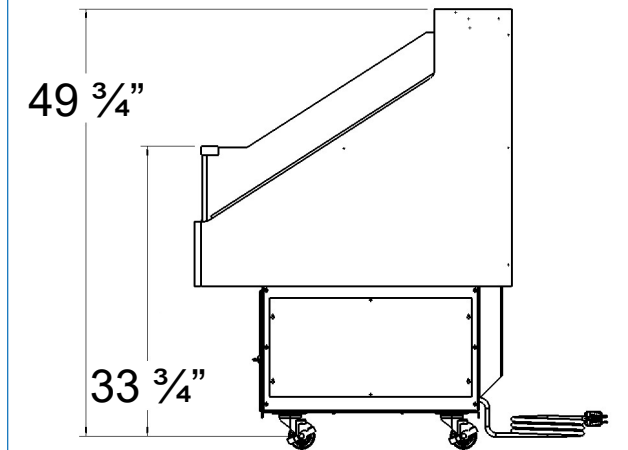

MODEL	DIMENSIONS*		POWER						
	A	B	V	Ph	Hz	MCA	MOP	HP	BTU/hr @ 75F
RBS032H	24"	36"	120	1	60	12.6	20	1/5	2920
RBS033H	36"	36"	120	1	60	13.7	20	1/5	2920
RBS034H	48"	36"	120	1	60	18.2	25	1/2	4750
RBS042H	24"	48"	120	1	60	13.7	20	1/5	2920
RBS044H	48"	48"	120	1	60	18.2	25	1/2	4750



Please refer to our website to see our wide range of materials, finishes, merchandising foam, and accessories

*Dimensions are approximate and will vary based on wrap styles

49" HIGH-VISIBILITY REFRIGERATED SLANT CASES

Critical
TEMP



49" H HIGH-VISIBILITY REFRIGERATED SLANT CASES

DESCRIPTION

JSI's critical temp Refrigerated Slant Cases are available in our full range of styles and finish options to perfectly match your entire department. The low front design allows for maximum product visibility and a variety of merchandising options.

BEST USED FOR:

- Front Entry
- Island Groupings
- Mix & Match with Refrigerated and Ambient Fixtures
- Berries

FEATURES



Electronic Controls

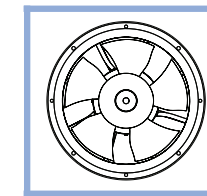

High-Efficiency Fan Motors

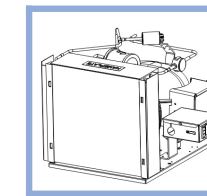

High-Efficiency Condensing Unit

STANDARD FEATURES

- High Efficiency Motors
- Digital Solar Thermometer
- Removable Service Panels
- Electronic Control
- Designed to Maintain Product Temperatures at <41°F
- Electric Condensate Pan

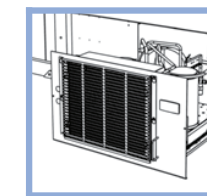

Slide-Out Service Drawer

OPTIONAL ACCESSORIES

- Merchandising Steps
- Various Shelf Styles and Sizes
- Corner Guards and Brackets
- Adjustable Wire Deck
- Foam Pad
- Price Tag Molding
- Magnetic Filter Screen
- Available in metal or wood wrap and in a variety of finishes

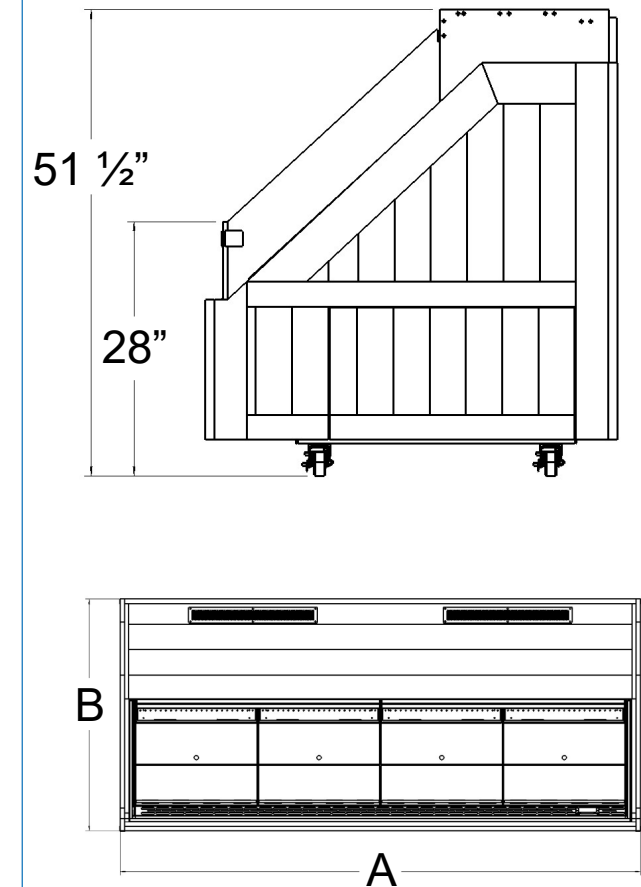

 **JSI** Delivering a *fresh* experience
an  company

MODEL	DIMENSIONS*		POWER						
	A	B	V	Ph	Hz	MCA	MOP	HP	BTU/hr @ 75F
RBS036HV-49	74 1/2"	44 1/2"	208	1	60	15.3	20	3/4	7660
RBS038HV-49	101"	44 1/2"	208	1	60	18.5	25	1	9180
RBS0310HV-49	125 1/2"	44 1/2"	208	1	60	21.3	25	1 1/4	11900
RBS0312HV-49	149 1/2"	44 1/2"	208	1	60	23.3	30	1 1/4	11900



Please refer to our website to see our wide range of materials, finishes, merchandising foam, and accessories

*Dimensions are approximate and will vary based on wrap styles

FRESH TO GO REFRIGERATED 3-SIDED ROUND CASES

TYPE II CERTIFIED



Critical
TEMP

FRESH TO GO REFRIGERATED 3-SIDED ROUND CASES

DESCRIPTION

Fresh To Go is our new line of refrigerated merchandisers that accommodate almost any store layout. Adjustable shelving allows you to fit a variety of products and create the perfect display. Flat back panel offers a number of configuration options.

BEST USED FOR

- Spot Merchandising
- Promotional displays
- Convenience stores
- Prepackaged meals

FEATURES



HEIGHT ADJUSTABLE
SHELVES

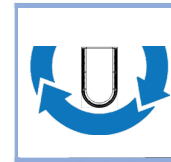

180° OF
MERCHANDISING



EASY ACCESS
CONTROLS

STANDARD FEATURES

- High Efficiency Motors
- Digital Solar Thermometer
- Removable Service Panels
- Electronic Control
- Designed to Maintain Product Temperatures at <41° F
- Electric Condensate Pan

OPTIONAL ACCESSORIES

- LED canopy lighting
- LED shelf lighting
- Custom Powdercoat options
- "Organics" product stops

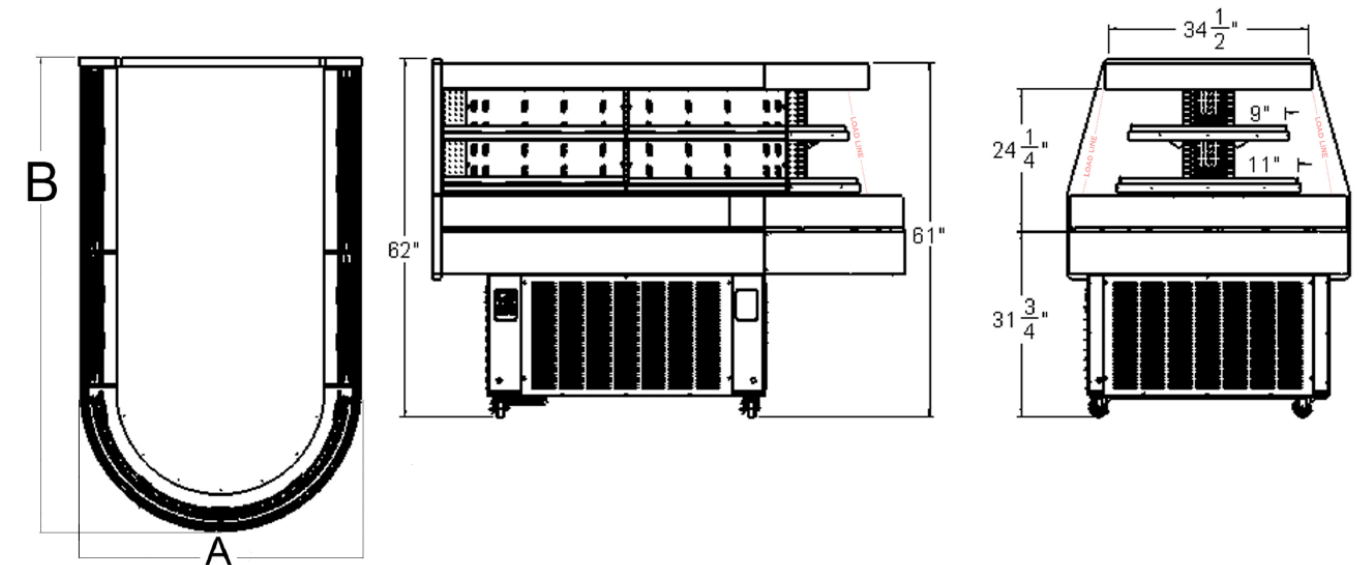

MODEL	DIMENSIONS*		POWER						
	A	B	V	Ph	Hz	MCA	MOP	HP	BTU/hr @ 75F
RIU046-62-FB	48 1/2"	82"	208	1	60	29.3	40	1 1/2	14700



2017
JOE
COMPLIANT

Please refer to our website to see our wide range of materials, finishes, merchandising foam, and accessories

*Dimensions are approximate and will vary based on wrap styles



FRESH TO GO REFRIGERATED ROUND CASES

TYPE II CERTIFIED

Critical
TEMP



FRESH TO GO REFRIGERATED ROUND CASES

DESCRIPTION

Fresh To Go is our new line of refrigerated merchandisers that accommodate almost any store layout. These can be merchandised from 270, or a full 360 degrees! Adjust shelving up or down to create the perfect display.

BEST USED FOR

- Spot Merchandising
- Promotional displays
- Convenience stores
- Prepackaged meals

FEATURES



HEIGHT ADJUSTABLE SHELVES

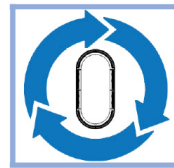

360° OF MERCHANDISING



EASY ACCESS CONTROLS

STANDARD FEATURES

- High Efficiency Motors
- Digital Solar Thermometer
- Removable Service Panels
- Electronic Control
- Designed to Maintain Product Temperatures at <41° F
- Electric Condensate Pan

OPTIONAL ACCESSORIES

- LED canopy lighting
- LED shelf lighting
- Custom Powdercoat options
- "Organics" product stops

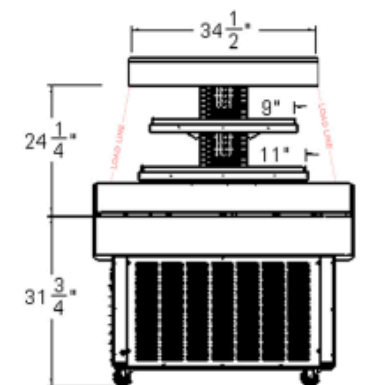
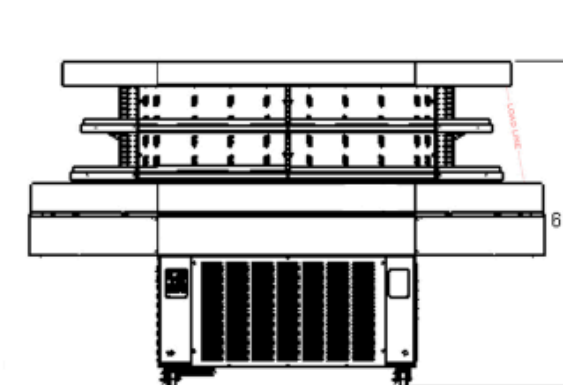
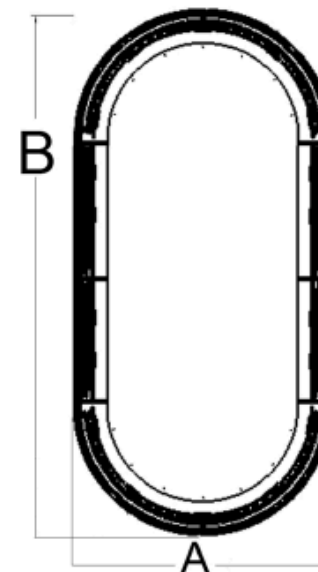

MODEL	DIMENSIONS*		POWER						
	A	B	V	Ph	Hz	MCA	MOP	HP	BTU/hr @ 75F
RIU048-62-F	48 1/2"	96"	208	1	60	40.8	60	2 1/2	23600



Please refer to our website to see our wide range of materials, finishes, merchandising foam, and accessories

*Dimensions are approximate and will vary based on wrap styles

84" HIGH SLIM REFRIGERATED MULTI DECKS

24" OUTSIDE DEPTH

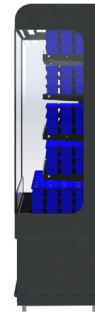

ARGON FILLED GLASS SIDES

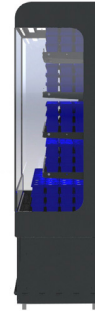

ACRYLIC SIDES



WOOD LAMINATED SIDES

JSI Delivering a *fresh* experience
an  company

84" HIGH SLIM REFRIGERATED MULTI DECK

DESCRIPTION

Our new refrigerated line of slim multi deck merchandisers can do it all! Place one in aisle with existing shelving or as a spot merchandiser for beverages. JSI offers 3 styles per size, creating plenty of configuration options.

BEST USED FOR

- In-Aisle Refrigeration
- Spot Merchandising
- Wine/Beverage
- Prepackaged meals

FEATURES

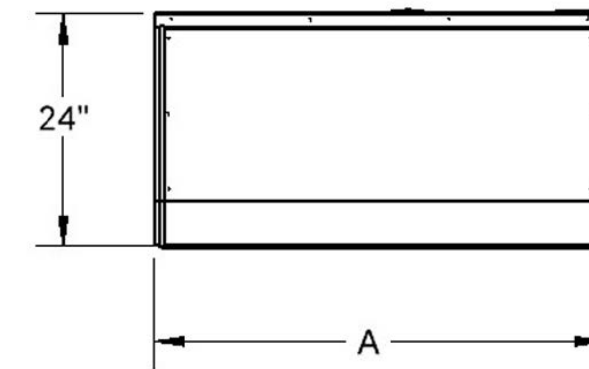

STANDARD FEATURES

- High Efficiency Motors
- Digital Solar Thermometer
- Removable Service Panels
- Electronic Control
- Designed to Maintain Product
- Temperatures at <41 F
- Electric Condensate Pan
- Laminated side panels
- 4 Standard 12" or 15" Shelves
- 12" Maximum Shelf Depth

OPTIONAL ACCESSORIES

- LED lighting
- Custom Wood accent piece
- Clear Acrylic sides
- Clear Argon filled glass sides

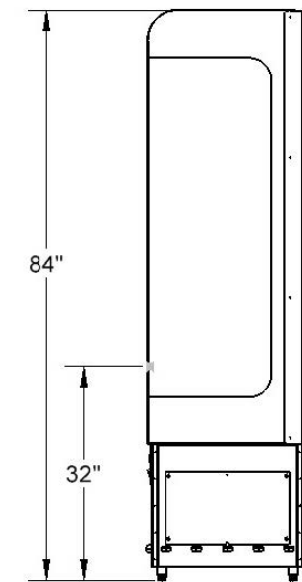

MODEL	DIMENSIONS*		POWER						
	A	B	V	Ph	Hz	MCA	MOP	HP	BTU/hr @ 75F
RMD022S-84	23 1/2"	24"	110	1	60	20.5	30	1/2	4750
RMD023S-84	35 1/2"	24"	220	1	60	15.5	30	3/4	6090
RMD024S-84	47 1/2"	24"	220	1	60	16	25	1	8540



Please refer to our website to see our wide range of materials, finishes, merchandising foam, and accessories

*Dimensions are approximate and will vary based on wrap styles

INNOVATIVE GRAB & GO DISPLAYS FOR CONVENIENCE

Our plug-and-play self-contained refrigerated Grab & Go cases are the perfect solution for displaying both dry and fresh refrigerated products in one convenient place.



Grab & Go Refrigerated Island Tower



Modular design suits any program and allows for a number of island configurations.



Grab & Go Refrigerated Island Line Up - 3 Units



Grab & Go Refrigerated Island Line Up - 4 Units

PERIMETER AND IN-LINE REFRIGERATED MERCHANDISER

Designed to maximize merchandising space in a lower profile case, our perimeter and in-line refrigerated merchandisers offer a large display window for high-visibility and easy customer access. These units are built to last and are offered in self-contained and remote options.



CREATE EYE-CATCHING FRESH DISPLAYS WITH A VARIETY OF DRY AND REFRIGERATED FIXTURES

Customers choose where they shop by the quality and freshness of their produce. Visually exciting displays help you merchandise and extend product life while communicating a market feel.



FRESH PRODUCE DISPLAYS

Available in a variety of sizes, styles and finishes with accessories and features to reduce shrink and meet your fresh program initiatives.



 **JSI** Delivering a *fresh* experience
an  company

FRESH BAKERY SOLUTIONS TO SUIT YOUR STYLE

Available in a variety of sizes, styles and finishes to meet your fresh program initiatives.



BAKERY DISPLAY TABLES



PROMO TABLES

Displays designed to quickly and easily adjust to manage capacity, keeping display looking full and fresh.



PROMO TABLES



CONFIGURATIONS

JSI is able to perfectly coordinate materials and finishes for refrigeration, floor displays and millwork.



CONFIGURATIONS

Remote refrigeration designed to fit together and manage your retail fresh program



To learn more about how JSI can provide the perfect solution for you, contact us:



Call [800.332.5507](tel:800.332.5507)



Email info@jsistorefixtures.com



140 Park Street • Milo, Maine 04463 • 800.332.5507 TEL • 207.943.5632 FAX • JSISTOREFIXTURES.COM
Milo, Maine • Bangor, Maine • Payson, Utah • Collingwood, Ontario