

2-SIDED MOBILE DISPLAY CART



140 Park Street • Milo, Maine 04463 • 800.332.5507 TEL • 207.943.5632 FAX • JSISTOREFIXTURES.COM
Milo, Maine • Bangor, Maine • Suwanee, Georgia • Payson, Utah • Greenville, South Carolina • Collingwood, Ontario

2-SIDED MOBILE DISPLAY CART

DESCRIPTION

Our 2-Sided Mobile Display Carts have LED lights to enhance your products and are a great way to highlight your signature bakery items to dramatically increase sales.

12-PAN, 2-SIDED MOBILE DISPLAY CART SHOWN WITH FLIP-UP SHELF AND OPTIONAL BUMPER

FEATURES

- Available in 2 Sizes: 8-Pan or 12-Pan Capacities
- 2 Levels of LED Lighted Shelves on Each Side
- Shelves Sized to Fit Standard 13"L x 18"D Half Muffin Pan or Pastry Trays
- 2 Tissue/Bag Holders
- Hardwood Slatted Flip-Up Shelf for Packaged Product Display
- Locking Casters

OPTIONS

- Variety of Materials / Stains / Options

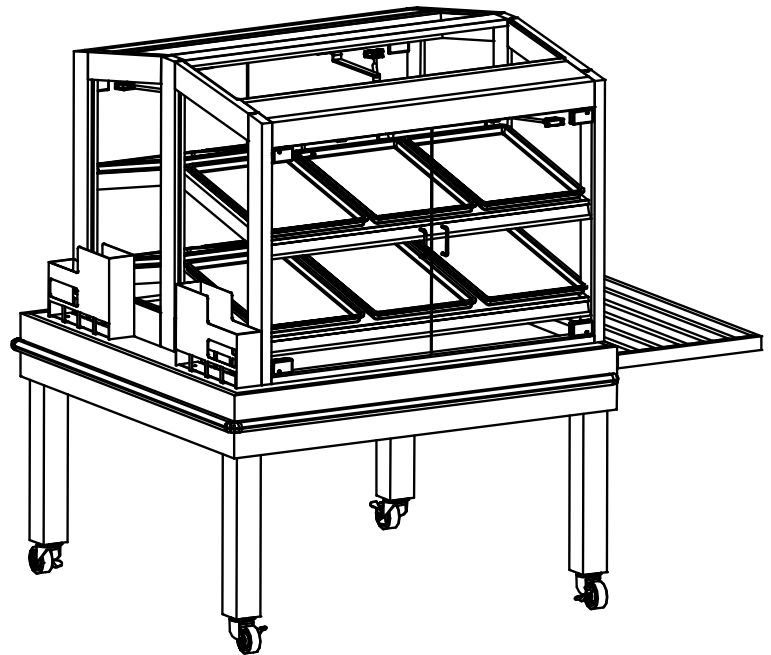

APPLICATIONS

- Use as a Spot Merchandiser for Muffins or Various Bakery Items

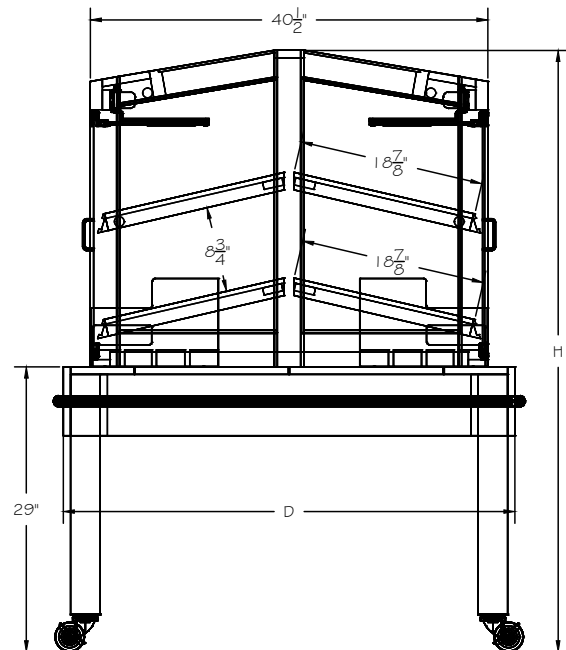
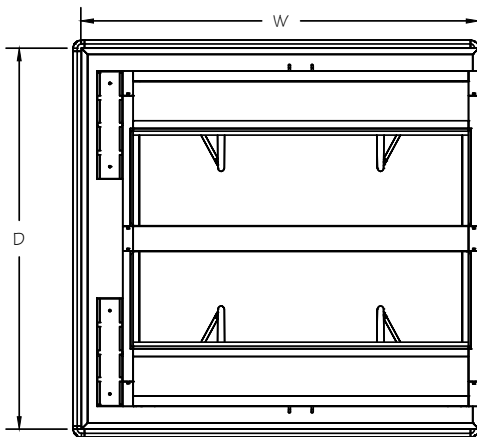

STYLE	ITEM #	SIZES W x D x H
2-SIDED MOBILE DISPLAY CART	C-MDC	36" X 46" X 61" 48" X 46" X 61"

Consult JSI Sales Associate for Available Glass Shields and Countertop Surfaces

MATERIALS, FINISHES, AND ACCESSORIES

Please refer to our "Stains and Accessories" brochure to see our wide range of materials, finishes, and accessories.