

WEDGE BIN



SEBAGO STYLE



BAXTER STYLE



BRUNSWICK STYLE



WEDGE BIN

DESCRIPTION

JSI's Wedge Bin creates a unique merchandising space and softens a corner. Works as a great feature-item bin in a "Mix Your Fixtures" group.

ITEM SHOWN IN BRUNSWICK STYLE WITH OPTIONAL LOWER MERCHANDISING SHELVING AREA AND CORNER BRACKETS

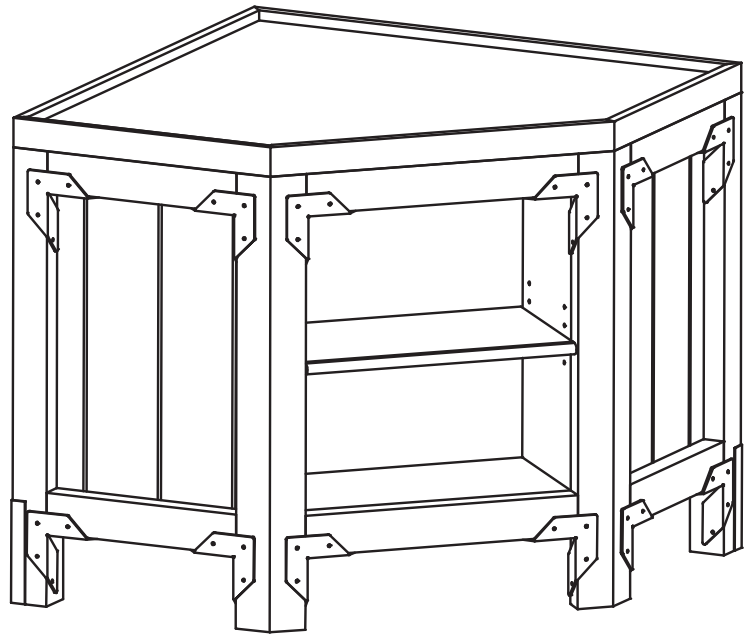

FEATURES

- Large Merchandising Area
- 1/2" Antimicrobial Foam Top
- Variety of Colors / Styles / Options

APPLICATIONS

- Use as a stand-alone for loose and packaged produce or in an island setting
- Incorporate with JSI refrigerated and non-refrigerated products

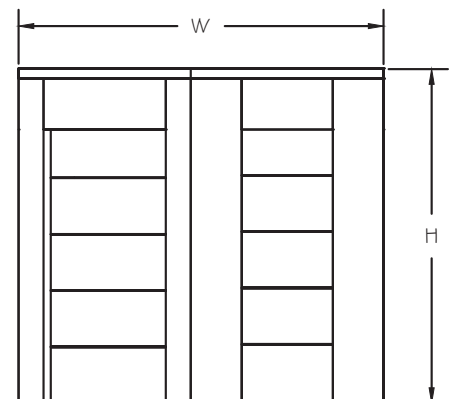
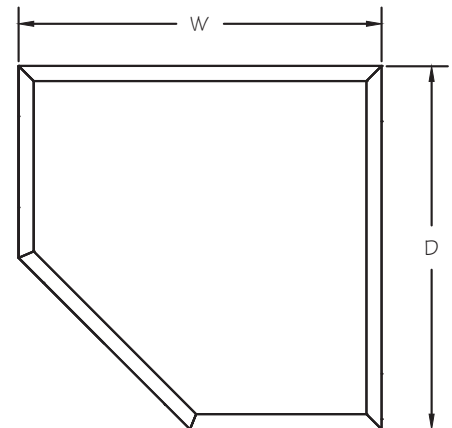

STYLE	ITEM #	LOWER SHELVING	SIZES W x D x H
SEBAGO	CSC-WBD	-S	36" X 36" X 33"
BAXTER	CBAX-WBD	-S	36" X 36" X 25 3/4"
BRUNSWICK	CBC-WBD	-S	48" X 48" X 33"
			48" X 48" X 25 3/4"

AVAILABLE FOAM FOR ORCHARD BINS	
EXCLUSIVE JSI, CLOSED CELL, ANTIMICROBIAL FOAM	
STYLE	ITEM #
1/2" Pad	F.5P
1" Pad	F.1P
Pocket Pad	F.PP
16" Filler Block	FFB16
23" Filler Block	FFB23

MATERIALS, FINISHES, FOAM, AND ACCESSORIES

Please refer to our "Styles, Groupings, Stains, and Accessories" brochure to see our wide range of materials, finishes, merchandising foam, and accessories.