

SLANT BIN



SEBAGO STYLE



BAXTER STYLE



BRUNSWICK STYLE



SLANT BIN

DESCRIPTION

Our Slant Bin elevates products for a traditional presentation. It's similar to the Euro Table, but designed to provide a market-style presentation. The Slant Bin works with all JSI Antimicrobial Foam products.

ITEM SHOWN IN BAXTER STYLE IN LEFT-HAND CONFIGURATION WITH OPTIONAL LOWER FRONT MERCHANDISING SHELVES

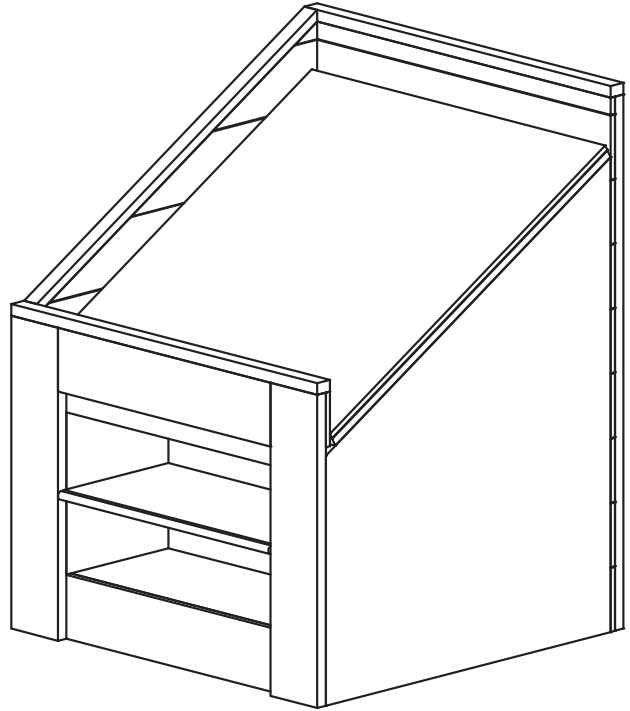

FEATURES

- Available as a Stand-Alone Unit or in Left/Center/Right Units for an Island Setting
- 1/2" Antimicrobial Foam
- Large Merchandising Area for Produce
- Variety of Colors / Styles / Options

APPLICATIONS

- Use as a stand-alone or end cap for loose and packaged produce or in an island setting
- Incorporate with JSI refrigerated and non-refrigerated products
- Available with lower front merchandising shelf area

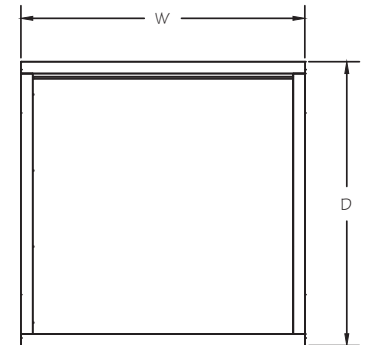

STYLE	ITEM #	CONFIGURATION DESCRIPTION	CONFIGURATION #	W X D X H
SEBAGO	CSC	Slant Bin Left	SBDL	36" X 36" X 47" 48" X 36" X 47"
BAXTER	CBAX	Slant Bin Right	SBDR	
BRUNSWICK	CBC	Slant Bin Center	SBDC	
		Slant Bin Stand-Alone	SBD	

AVAILABLE FOAM FOR SLANT BINS/EUROS	
EXCLUSIVE JSI, CLOSED CELL, ANTIMICROBIAL FOAM	
STYLE	ITEM #
Banana Bed	FBB
Stone Fruit Riser	FSF
Perfect Riser	FPR
Step Riser	FSR
Pocket Pad	FPP
1/2" Pad	F5P
1" Pad	FIP

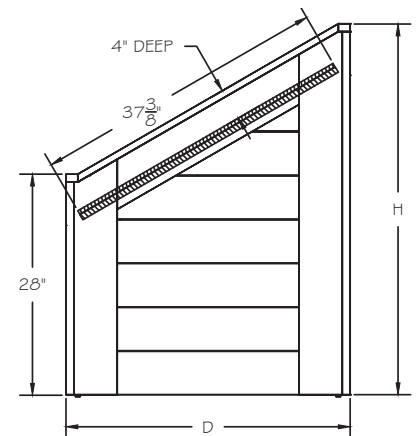

MATERIALS, FINISHES, FOAM, AND ACCESSORIES

Please refer to our "Styles, Groupings, Stains, and Accessories" brochure to see our wide range of materials, finishes, merchandising foam, and accessories.