

STYLES, GROUPINGS, STAINS, AND ACCESSORIES



CHOOSE YOUR STYLE

Choose from three styles to fit your space. Customize the fixtures to suit your needs with accessories and many choices in stains and finishes.



SEBAGO

- Built using textured and somewhat inconsistent materials with lots of grain and color variation.
- Accepts stain inconsistently.

BAXTER

- Built using textured and somewhat inconsistent materials with lots of grain and color variation.
- Accepts stain with moderate variations.

BRUNSWICK

- Built with smooth, consistent materials and surfaces.
- Accepts stains with minor variations.

SEBAGO



BAXTER



BRUNSWICK



GROUPING IDEAS

Use one of the grouping examples we've put together, or create your own and build the right experience for your customers!



GROUPING EXAMPLE 1

- 3' x 3' Orchard Bins
 - 36" x 18" Spillover Bins
 - 3' x 3' Pedestal Riser
 - 8" H Orchard Bin Elevator
- Style:** Baxter
Wood Species: Rough Maple
Color/Finish: Early American



GROUPING EXAMPLE 2

- Back-to-back 3' x 3' Slant Bins with Bananabed® Foam Risers
 - 36" x 18" Spillover Bins
- Style:** Sebago
Wood Species: Douglas Fir with Soft Maple
Color/Finish: Clear



GROUPING EXAMPLE 3

- 3' x 3' Refrigerated Slant Bin with 5-Step Riser
 - 8' x 3' Refrigerated Slant Bins
 - 3' x 3' Wedge Bins with Pedestal Risers
- Style:** Brunswick
Wood Species: Maple
Color/Finish: Clear

MIX YOUR FIXTURES!

JSI is the only company able to provide a complete product line that will assure department-wide integration and maximize product impact to the customer.

CHECK THE LIST!

- ✓ Dry Orchard Bins
- ✓ Refrigerated Orchard Bins
- ✓ Dry Slant Bins
- ✓ Refrigerated Slant Bins
- ✓ Euro Tables and Accessories
- ✓ Merchandising Accessories for All
- ✓ Closed-Cell Antimicrobial Foam
- ✓ Materials and Finishes



GROUPING EXAMPLE 4

- Back-to-Back 8' x 3' Refrigerated Slant Bins
 - 6' x 3' Refrigerated Orchard Bins
- Style:** Baxter
Wood Species: Rough Maple
Color/Finish: Early American



GROUPING EXAMPLE 5

- 3' x 3' Refrigerated Slant Bin
 - 4' x 3' Euro Tables
- Style:** Brunswick
Wood Species: Maple
Color/Finish: Clear



GROUPING EXAMPLE 6

- 3' x 3' Orchard Bins with Pedestal Risers
 - 3' x 3' Slant Bins (back)
 - 6' x 3' End Caps with Foam Risers
- Style:** Baxter
Wood Species: Rough Maple
Color/Finish: Early American

GROUPING IDEAS

Use one of the grouping examples we've put together, or create your own and build the right experience for your customers!



GROUPING EXAMPLE 7

- Back-to-back 8' x 3' Refrigerated Slant Bins
- 6' x 3' End Cap Displays for Refrigerated Slant Bins

Style: Sebago

Wood Species: Douglas Fir with Soft Maple

Color/Finish: Clear



GROUPING EXAMPLE 8

- Back-to-back 3' x 3' Potato/Onion Bins
- 6' x 3' End Cap with Foam Risers
- 72" x 18" Spice Rack Bin Display

Style: Baxter

Wood Species: Rough Maple

Color/Finish: Early American



GROUPING EXAMPLE 9

- 3' x 3' Refrigerated Orchard Bins with Pedestal Riser
- 3' x 3' Orchard Bins with Pedestal Riser
- 3' x 3' Wedge Bins with Pedestal Risers

Style: Sebago

Wood Species: Douglas Fir with Soft Maple

Color/Finish: Clear

TIE YOUR ENTIRE PRODUCE DEPARTMENT TOGETHER WITH REFRIGERATED AND NON-REFRIGERATED FIXTURES FROM JSI.



GROUPING EXAMPLE 10

- 6' x 6' 3 Tiered Refrigerated Bin Island
- 36" x 18" Spillover Bin with Shelf

Style: Baxter

Wood Species: Rough Maple

Color/Finish: Early American



GROUPING EXAMPLE 11

- Back-to-back 3' x 3' Slant Bins with BananaBed® Foam Risers
- 6' x 3' End Caps with Foam Risers

Style: Brunswick

Wood Species: Maple

Color/Finish: Clear



GROUPING EXAMPLE 12

- 6' x 3' 2 Tiered Refrigerated Bin
- 3' x 3' Orchard Bin with Pedestal Riser
- 3' x 3' Wedge Bin with Pedestal Riser

Style: Sebago

Wood Species: Douglas Fir with Soft Maple

Color/Finish: Clear

KEEP IT BEAUTIFUL.

Eye Catching
Market Appeal
Textures and Finishes

STAINS

JSI offers a range of finishes that look great and apply attractively on our standard variety of wood surfaces. One of these is sure to make an impression with your new design theme.



Early American
(Item #: STN 020)



MDI Cherry
(Item #: STN 024)



Clear - Dull Rub
(Item #: LAQ 015)
Shown on Soft Maple



Victorian Mahogany
(Item #: STN 014)



Rustic Gray
(Item #: STN 053)



Select Cherry
(Item #: STN 017)



Wild Cherry
(Item #: STN 005)



Bistro Walnut
(Item #: STN 035)

Different styles will take stains differently. Please contact Customer Service to learn more.

PROTECT YOUR FIXTURES

Give your displays the finishing touches that enhance your store's ambiance.



CORNER BRACKETS
Black
(Item #: BRC Black)



CORNER GUARDS
Black
(Item #: AGL Black)



BUMPER
Black
(Item #: BMP 001 - 1" black bumper)

Accessories will be priced separately from fixtures.

CRATES

Add to your fresh market look with some authentic field crates.



JSI'S AUTHENTIC CRATES GIVE YOUR TEAM A FLEXIBLE AND CREATIVE WAY TO CROSS MERCHANDISE ITEMS THROUGHOUT YOUR STORE.

REFRIGERATION ACCESSORIES

2-STEP RISER

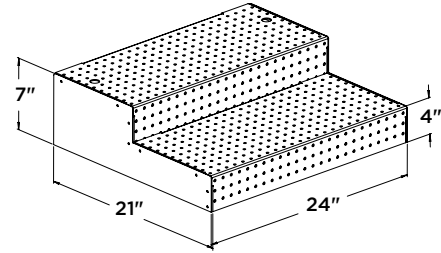

36" wide available for model RBS033

3-STEP RISER

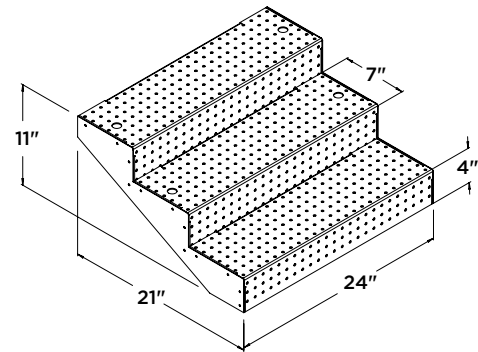

36" wide available for model RBS033

5-STEP RISER

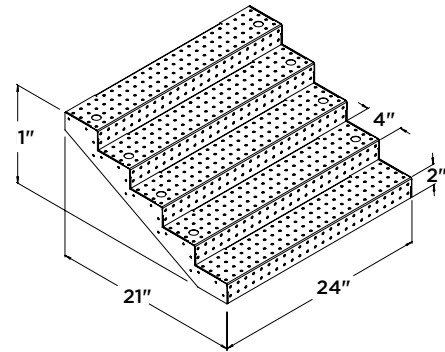

36" wide available for model RBS033

ADJUSTABLE PEDESTAL RISER

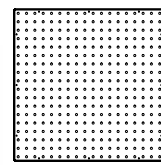

18" square

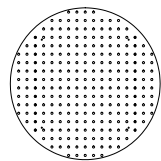

18" round

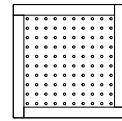

12" square

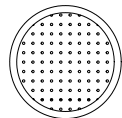

12" round

Each kit comes with one top and one 4" riser. Additional risers are available. All towers available with and without wood trim.

RISERS, SHELVES, AND PRICE TAG MOLDING LET YOU CUSTOMIZE DISPLAYS TO SUIT YOUR SPECIFIC NEEDS.

12" PRODUCT SHELF

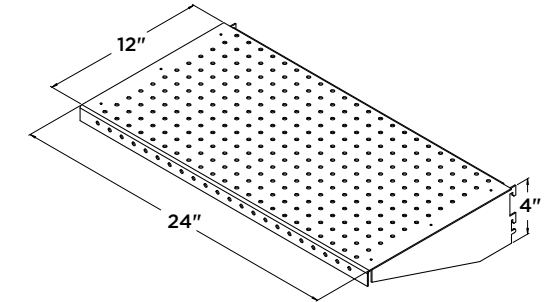

36" wide available for model RBS033

6" EXTENDABLE SHELF

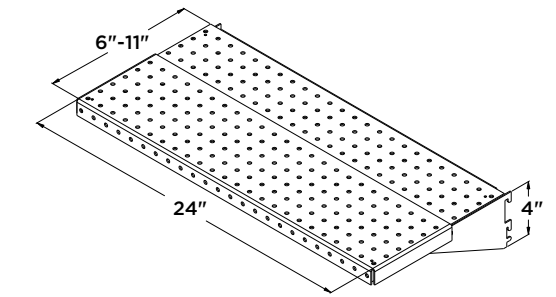

36" wide available for model RBS033

TILTABLE SHELF

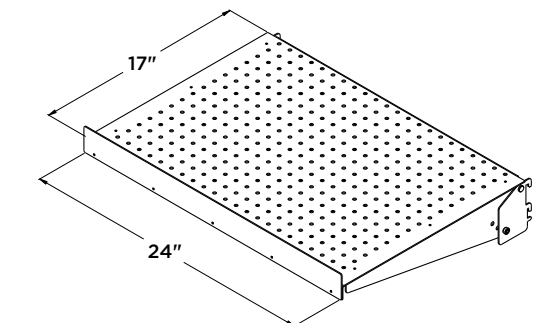
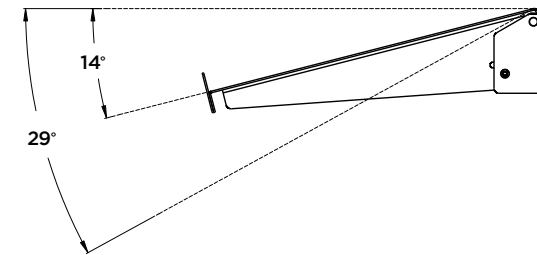

36" wide available for model RBS033

PRICE TAG MOLDING

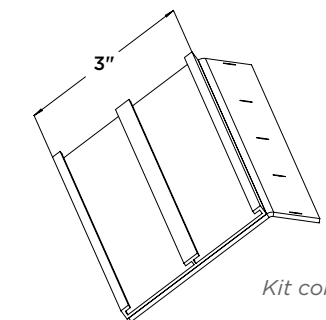

Kit comes in 36" or 48"

DRY BIN AND EURO TABLE ACCESSORIES

Customize your displays with crates, risers, elevators, and product stops to create a unique look in your produce department.

CRATE

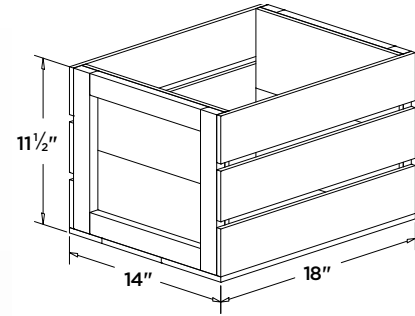

ROUND RISER

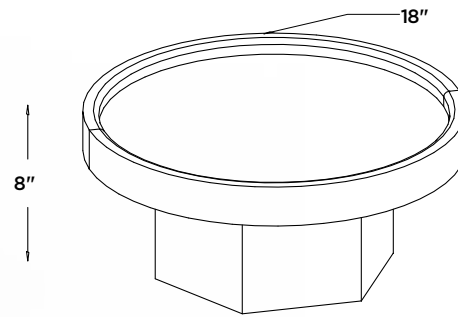

SQUARE RISER

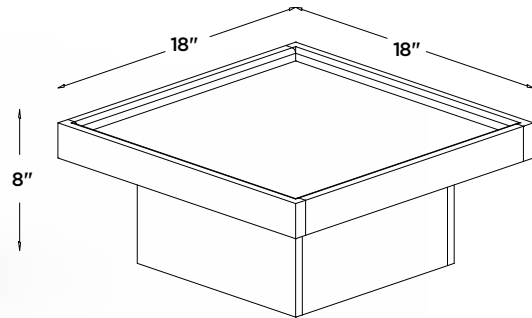

WEDGE RISER

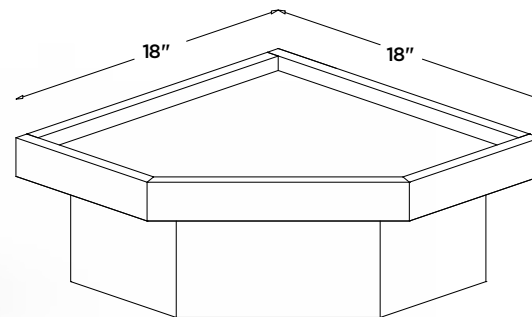

JSI'S ACCESSORIES ARE SIZED TO WORK WITH ALL OF OUR FIXTURES. USE YOUR IMAGINATION TO CREATE EYE-CATCHING DISPLAYS THAT HIGHLIGHT PRODUCT AND DRIVE SALES HIGHER.

SEBAGO BIN ELEVATOR

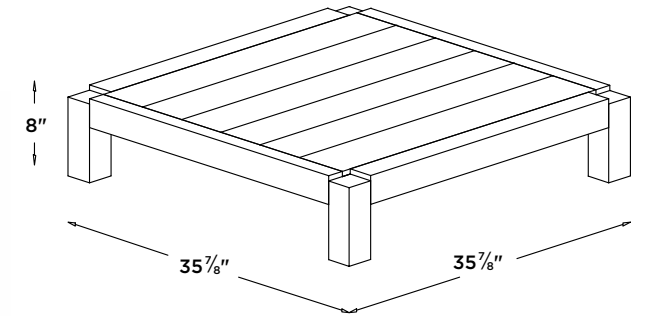

BAXTER BIN ELEVATOR

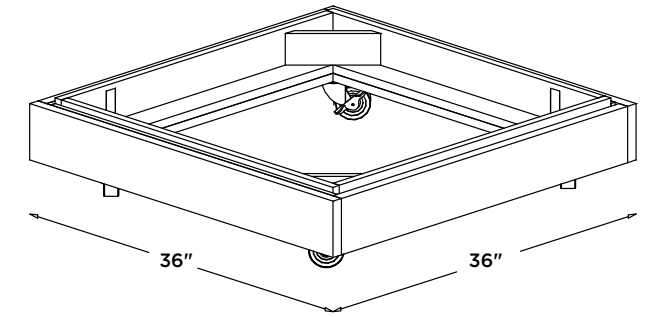

BRUNSWICK BIN ELEVATOR

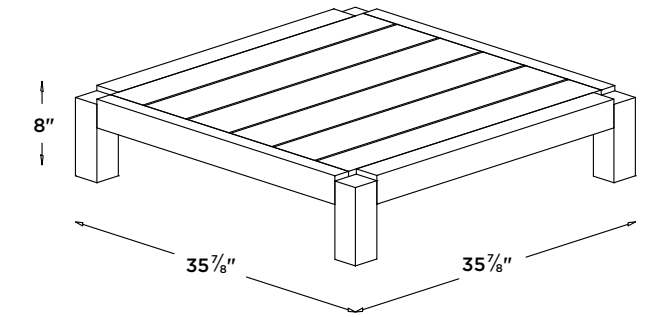

OPTIONAL ACRYLIC PRODUCT DIVIDERS AND ABS PRODUCT STOPS

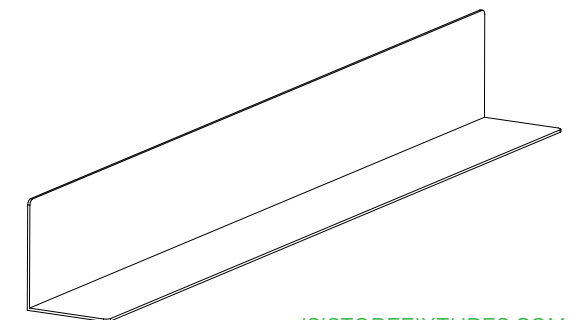



KEEP IT *FRESH.*

**Extend Life
Reduce Shrink
Minimize Damage**



**EURO TABLE
Stone Fruit Riser**
See Page 17

THE FIRST AND ONLY ANTIMICROBIAL CLOSED-CELL MERCHANDISING FOAM.

Our line of merchandising surfaces are made of a smooth, nonabsorbent, closed-cell foam which helps prevent fruits and vegetables from being bruised,

keeping them looking their very best for your customers. Drives traffic and increases sales with quality and freshness in your produce department.



CLOSED-CELL FOAM

JSI's foam is the only closed-cell foam available in the industry. Manufactured using the same technology as in salt water buoys, our foam is 100% moisture resistant. This assures you that no bacteria can penetrate any part of the foam and grow. Even if cut, this property is maintained. No other foam or padding has this benefit.



ANTIMICROBIAL FOAM

- Inhibits the growth of microbes that could degrade the product.
- Protects the foam from degradation caused by microbes.
- Guards against degradation from microorganisms.
- Guards against the growth of odors from microbial causes.



REDUCE SHRINK & INCREASE PROFITS

- Closed-cell assures bacteria can't hide.
- Antimicrobial assures bacteria can't grow.
- Foam pad assures reduced bruising.
- Multiple shapes assure awesome presentation.
- Be assured, JSI foam will help reduce shrink and increase sales leading to increased profits and customer satisfaction.

PERFECTRISER™



Less product, more impact. The PerfectRiser™ features an arched design that rises in the middle, giving the appearance of more product on display. Built-in horizontal product stops keep produce from rolling off. PerfectRisers can be custom cut to size and used in conjunction with optional product dividers and product stops.

STONEFRUITRISER



Reduce shrink. The scooped design of the StoneFruit Riser allows for better product visibility and the appearance of more product being displayed. Balanced rows make product rotation a snap—no more roll-away produce during restocking. Available in 6 or 8 scoops, and can be custom cut to fit any space.

BANANABED®



Extend product life. The JSI BananaBed® is our most popular line of ProduceBuddy® foam. It is ultra soft, extra durable, lightweight and easy to clean. Available in 4 or 5 scoops, the BananaBed® can be custom cut to fit any space. Your bananas never had it so good!

STEPSRISER



Improve visibility. Elevate your fresh fruits and vegetables on the JSI StepRiser and make cleaning up spills and produce debris a snap. StepRisers also give the appearance of more product being displayed. Available in 2 or 3 steps, which are removable.

BERRYRISER



Step it up! Maintain a neat and enticing display with JSI's BerryRiser. The BerryRiser helps reduce damage and product shrink caused by overstacking merchandise. It keeps all your berries plump and juicy. Available in 7 or 9 steps, the BerryRiser can be custom cut to fit any space.

FOAMACCESSORIES



JSI's exclusive Closed-Cell, Antimicrobial Merchandising Foam is available in many thicknesses and shapes and can be cut to fit most surfaces. We can provide a foam program for all your merchandising surfaces.

MIX YOUR FIXTURES

With hundreds of combinations available, tie your entire produce department together with refrigerated and non-refrigerated fixtures from JSI.



MIX AND MATCH REFRIGERATED SLANT BINS, REFRIGERATED ORCHARD BINS, SLANT TABLES, AND END CAP DISPLAYS.



OUR CAPABILITIES



PRODUCE

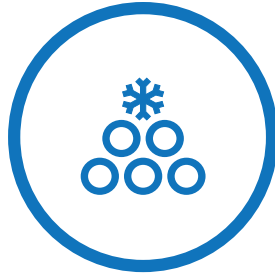

REFRIGERATION

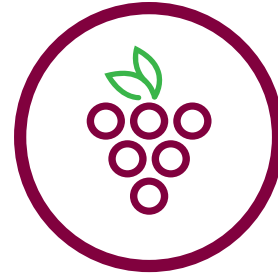

WINE

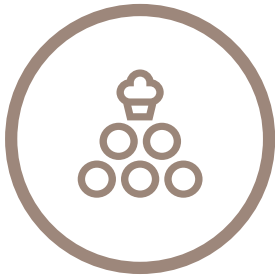

BAKERY

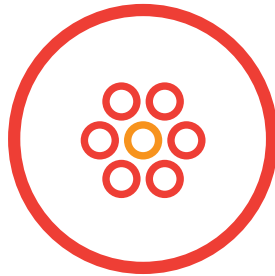

FLORAL



SPECIALTY

OUR LOCATIONS

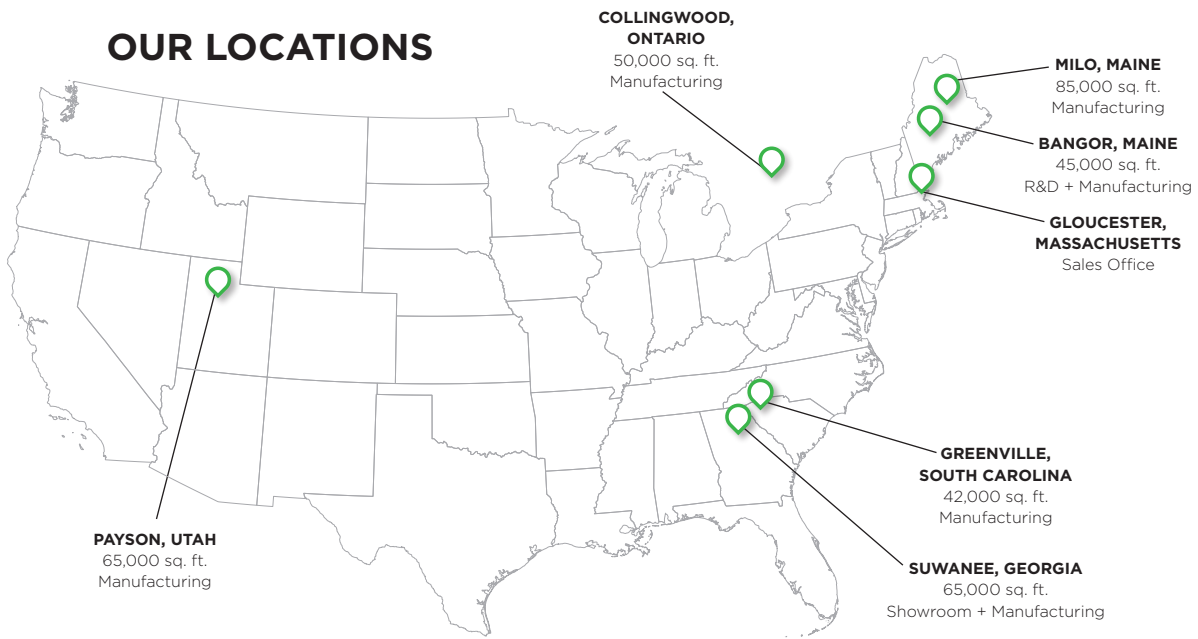

140 Park Street • Milo, Maine 04463 • 800.332.5507 **TEL** • 207.943.5632 **FAX** • JSISTOREFIXTURES.COM
 Milo, Maine • Bangor, Maine • Suwanee, Georgia • Payson, Utah • Greenville, South Carolina • Collingwood, Ontario