

# XLPG LED INSTALLATION AND ASSEMBLY INSTRUCTIONS



SMARTVISION®

**CAUTION:** Risk of shock. Disconnect power before installing or servicing.

**WARNING:** Before proceeding, read all instructions carefully to insure proper and safe installation.

**WARNING:** Risk of electrical shock. High temperatures inside luminaire. Make certain line voltage corresponds with ballast/driver primary voltage (see ballast/driver label).

**WARNING:** All wiring to be performed per National Electrical Code and local code by a qualified electrician.

**IMPORTANT:** Not every unit is identical. Placement of proper luminaire is important. Refer to layout drawing to verify location identification, product location, and feed points.

**IMPORTANT:** Do not electrically connect to live wiring.



Installation Questions?  
Call LSI Field Service Department at:  
1-800-436-7800 Ext. 3300 Fax 877-861-1368

LSI Industries Inc. ♦ 10000 Alliance Road ♦ Cincinnati, OH 45242 ♦ 513-793-3200 ♦ Fax (513) 793-0147 ♦ [www.lsi-industries.com](http://www.lsi-industries.com)

# **XLPG LED INSTALLATION AND ASSEMBLY INSTRUCTIONS**



**SMARTVISION®**

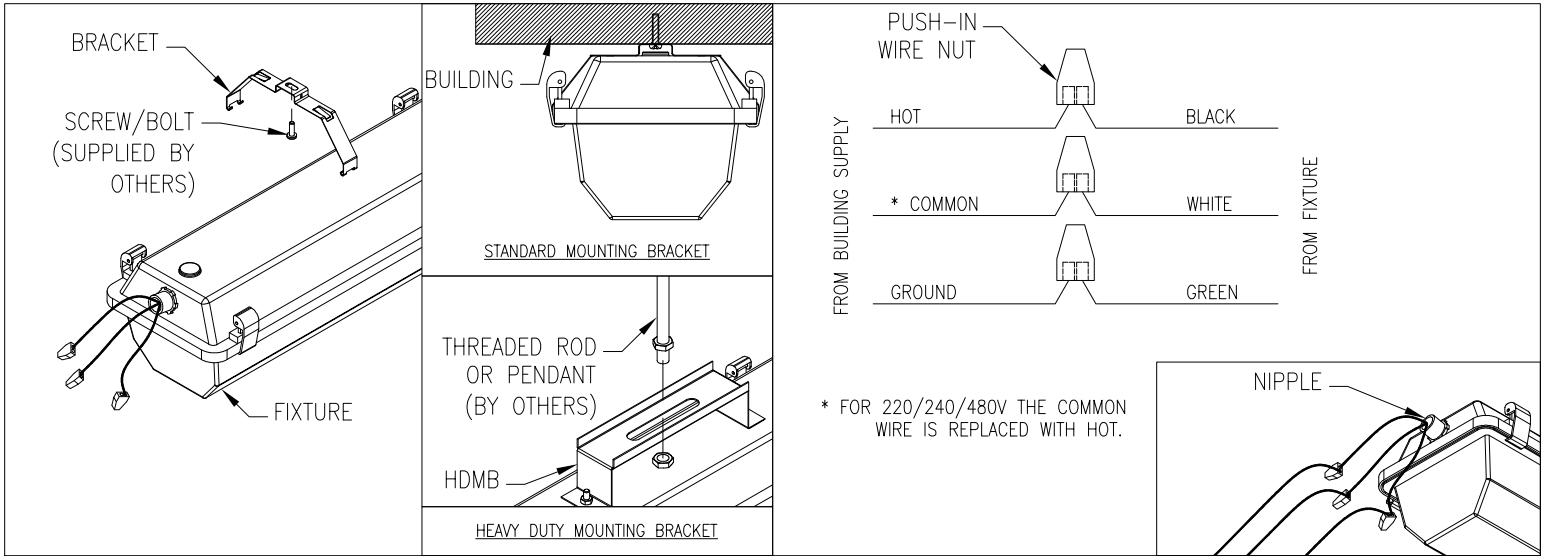

- |                                                                                                                                                                                                                                                                                                                     |                                                                                                                                                                                                                                                                                            |
|---------------------------------------------------------------------------------------------------------------------------------------------------------------------------------------------------------------------------------------------------------------------------------------------------------------------|--------------------------------------------------------------------------------------------------------------------------------------------------------------------------------------------------------------------------------------------------------------------------------------------|
| <p>1.) ATTACH BRACKETS TO BUILDING STRUCTURE (2 PER FIXTURE).<br/>                 2.) THEN LIFT FIXTURE INTO BRACKETS AND SNAP SECURE INTO PLACE ON BOTH ENDS.<br/>                 * FIXTURE MAY BE SUPPLIED WITH HEAVY DUTY MOUNTING BRACKETS (HDMB) FACTORY INSTALLED. (PENDANT AND LOCKING NUTS BY OTHERS)</p> | <p>3.) MAKE APPROPRIATE WIRE CONNECTIONS. (SEE DIAGRAM)<br/>                 4.) PUSH WIRE NUTS INTO NIPPLE CONNECTION ONE AT TIME AND THEN TIGHTEN CONDUIT FITTING OVER NIPPLE.<br/>                 5.) BATTERY BACK-UP OPTION – SEE MANUFACTURERS INSTRUCTIONS PACKED WITH FIXTURE.</p> |
|---------------------------------------------------------------------------------------------------------------------------------------------------------------------------------------------------------------------------------------------------------------------------------------------------------------------|--------------------------------------------------------------------------------------------------------------------------------------------------------------------------------------------------------------------------------------------------------------------------------------------|

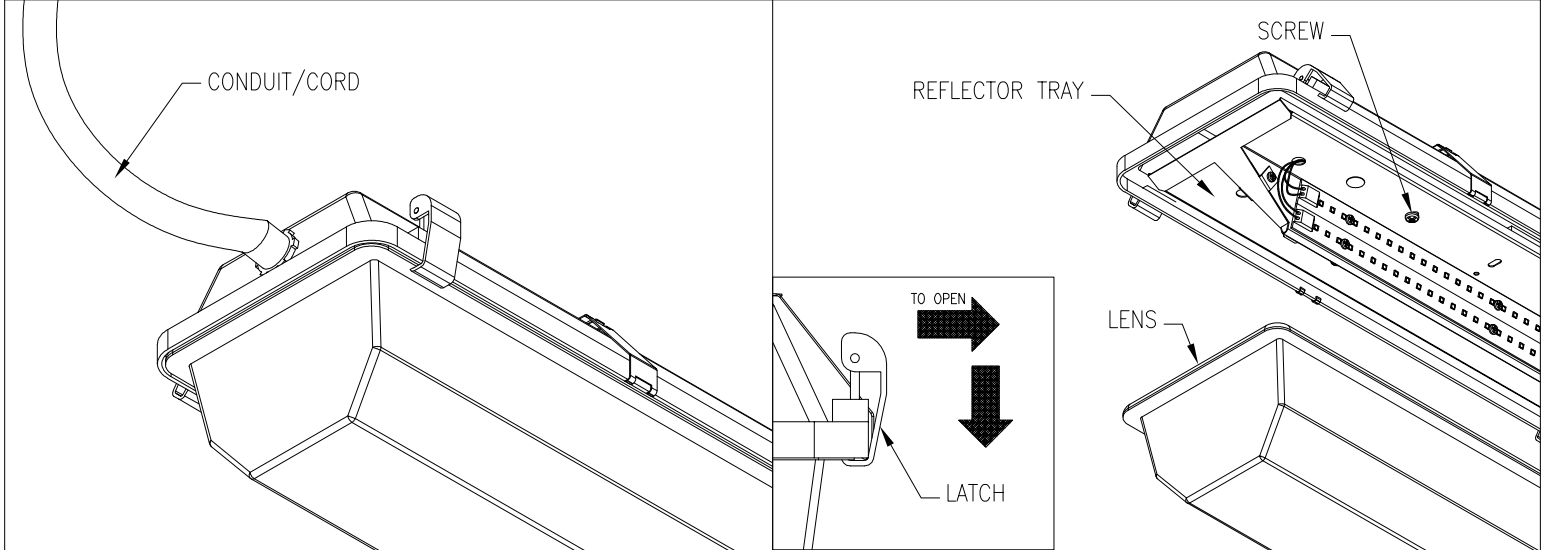

- |                                              |                                                                                                                                                                                                                                                                     |
|----------------------------------------------|---------------------------------------------------------------------------------------------------------------------------------------------------------------------------------------------------------------------------------------------------------------------|
| <p>6.) FIXTURE IS READY TO BE ENGERIZED.</p> | <p>7.) IF FIXTURE NEEDS TO BE SERVICED – OPEN THE LATCHES ON HOUSING TO REMOVE LENS. UNSCREW THE FOUR (4) SCREWS TO REMOVE THE REFLECTOR TRAY FOR ACCESS.<br/>                 8.) REPLACE COMPONENTS AND LOCK LATCHES BACK INTO PLACE WHEN FINISHED SERVICING.</p> |
|----------------------------------------------|---------------------------------------------------------------------------------------------------------------------------------------------------------------------------------------------------------------------------------------------------------------------|



Installation Questions?  
 Call LSI Field Service Department at:  
 1-800-436-7800 Ext. 3300 Fax 877-861-1368

