



# MLI Series

## Installation Instructions



### **IMPORTANT SAFEGUARDS READ AND FOLLOW ALL SAFETY INSTRUCTIONS.**

When using electrical equipment, basic safety precautions should always be followed including the following:

- DISCONNECT AC POWER SUPPLY BEFORE SERVICING.
- Installation and servicing of this equipment should be performed by qualified service personnel only.
- Ensure that the electrical wiring conforms to the National Electrical Code NEC® and local regulations, if applicable.
- Do not mount near gas or electric heaters.
- Do not use outdoors.
- Do not let power supply cords touch hot surfaces.
- Use caution when servicing batteries. Battery acid can cause burns to skin and eyes. If acid is spilled on skin or in eyes, flush acid with fresh water and contact a physician immediately.
- Equipment should be mounted in locations and at heights where it will not be readily subjected to tampering by unauthorized personnel.
- The use of accessory equipment not recommended by the manufacturer may cause an unsafe condition.
- Any modification or use of non-original components will void the warranty and product liability.
- The AC voltage rating of this equipment is specified on the product label. Do not connect equipment to any other voltage.
- Do not use this equipment for other than intended use.
- Allow battery to charge for 48 hours before first use.

**SAVE THESE INSTRUCTIONS!**





# MLI Series

## Installation Instructions

### TABLE OF CONTENTS

#### Specifications

- Table 1 - Physical Specifications ..... 3
- Table 2 - Electrical Specifications ..... 3

#### Receiving, Moving and Storing Systems and Batteries

- Shipping Damage ..... 4
- Temporary Storage of Units and Batteries ..... 4

#### Installation Requirements

- Operating Environment ..... 4
- High Altitude Operation ..... 4

#### Cabinet Mounting

- Tools Required ..... 5
- Mounting Hardware ..... 5
- Knockout Locations ..... 5
- Cabinet Mounting - Surface (SM) Models ..... 5
- Cabinet Mounting - Recessed (RM) Models ..... 5
- Cabinet Mounting - Ceiling T-Grid (TM) Models ..... 5

#### AC Connections

- AC Wiring Preparations ..... 6
- AC Input Voltage Selector Plug Installation ..... 6
- AC Input/Output Wiring Connections to Terminal Block ..... 6

#### Battery Information

- Tools ..... 8
- Battery Installation and Connection ..... 8
- Battery Voltage Check ..... 8

#### Final Installation Checklist ..... 9

#### System Start-Up Procedure ..... 9

#### System Test ..... 9

#### Maintenance

- Safe Shut Down Procedure ..... 10
- Routine System Maintenance ..... 10
- Manual Routine Inverter Tests ..... 10
- Routine Battery Inspection and Maintenance ..... 11
- Battery Replacement Procedure ..... 11
- Battery Disposal ..... 11

#### Instructions for Self-Test/Self-Diagnostics

- Self-Diagnostic Service ..... 12
- Table 3 - Service Indication ..... 12
- Table 4 - Manual Testing ..... 12





# MLI Series

## Installation Instructions

### SPECIFICATIONS

#### Input

- Input voltage: Universal 120VAC or 277VAC
- Input frequency: 60Hz  $\pm$ 2%

Input surge protection: Meets UL 924

#### Output

- Output voltage: Universal 120VAC or 277VAC, 60Hz. Other voltages available upon request
- Output regulation: (Static)  $\pm$ 5% based on a 0% - 100% resistive load
- Minimum loading: None required
- Output distortion: Less than 3% THD linear load
- Load power factor: 0.44 lead to 0.44 lag
- Output frequency:  $\pm$ 0.3HZ during emergency
- Time to transfer to inverter after a utility power failure: <1 second

#### Battery

**Note: Sealed lead calcium battery performance rated at 25°C (77°F) for load, NiCad battery performance rated at 0°C to 50°C (32°F to 122°F) for load.**

- Battery type: Maintenance-free sealed lead calcium or NiCad
- Battery charger: Fully automatic dual-mode with temperature compensation
- Recharge time: Meets UL requirements (96 hours)
- Battery protection: Automatic low-battery voltage disconnected and reverse polarity protection.
- Standard batteries lifespan: Sealed lead calcium: 7-year life, NiCad: 15-year life
- Battery voltage: 12VDC (all models)
- Runtimes: 90 minutes standard
- Operating temperature:
  - Sealed lead calcium models: 20°C to 30°C (68°F to 86°F)
  - NiCad models: 0°C to 50°C (32°F to 122°F)
- Relative humidity: 95% non-condensing

**Table 1 - Physical Specifications**

System Model Number	Housing Mounting Style	Housing Size	Number of Installed Batteries	Housing Dimensions			System Weight	
				Length	Height	Depth	(lbs)	(kg)
MLI 32 SM	Surface	Small	1	14 $\frac{3}{4}$ " (37.5cm)	7 $\frac{3}{8}$ " (18.7cm)	3 $\frac{1}{8}$ " (7.9cm)	14	6.4
MLI 55 SM		Large				4 $\frac{3}{8}$ " (11.1cm)	18	8.2
MLI 20N SM		Small				3 $\frac{1}{8}$ " (7.9cm)	11	5.0
MLI 35N SM		Large				4 $\frac{3}{8}$ " (11.1cm)	12	5.4
MLI 32 RM	Recessed	Small		16 $\frac{1}{4}$ " (41.3cm)	8 $\frac{7}{8}$ " (22.5cm)	3 $\frac{1}{8}$ " (7.9cm)	15	6.8
MLI 55 RM		Large				4 $\frac{3}{8}$ " (11.1cm)	19	8.6
MLI 20N RM		Small				3 $\frac{1}{8}$ " (7.9cm)	12	5.4
MLI 35N RM		Large				4 $\frac{3}{8}$ " (11.1cm)	13	5.9
MLI 32 TM	Ceiling Recessed	-	23 $\frac{3}{8}$ " (60.6cm)	6 $\frac{1}{4}$ " (15.8cm)	4.0" (10.2cm)	15	6.8	
MLI 55 TM		-				19	8.6	
MLI 20N TM		-				12	5.4	
MLI 35N TM		-				13	5.9	

\*System weights shown include installed batteries

**Table 2 - Electrical Specifications**

System Model Number	Input/Output Voltage (60Hz)	Capacity (90min) Watts/VA	Battery Type	Power Cosum. (Max.)	Battery Voltage (VDC)	DC Input Current (ADC)	Input Current		Thermal Output (BTU)		Temp Range (°C)
							120VAC (Max.)	277VAC (Max.)	Standby	Emergency	
MLI 55	120/227	55/55	Lead Calcium	9W	12	5.7	0.54A	0.23A	7	47	20 to 30
MLI 20N		20/20	NaCid			2.1	0.25A	0.11A	31	22	0 to 50
MLI 35N		35/35	NaCid			3.8	0.37A	0.16A	31	35	0 to 50



# MLI Series

## Installation Instructions

### RECEIVING, MOVING, AND STORING SYSTEMS AND BATTERIES

---

#### Shipping Damage

MLI inverter system batteries are shipped along with the unit within a single shipping carton. Batteries for most units are not shipped within the housing with the exception of Plenum Rated Ceiling Mount (T-Grid) models.

Carefully inspect all cartons upon receipt for evidence of shipping damage. Notify carrier immediately of leaking or damaged cartons for possible concealed damage.

#### Temporary Storage of Units and Batteries

For temporary storage of MLI inverter systems and batteries prior to installation, select a clean, cool, dry location with normal ventilation for human habitation and level floors.

#### Storage Temperature:

Store all batteries at 0°C to 40°C (32°F to 104°F). Batteries will have a longer shelf life if stored at 15°C (60°F). The MLI electronics and battery cabinets may be stored at -20°C to 60°C (-4°F to 140°F).

**IMPORTANT:** Lengthy storage of batteries will cause irreversible damage to the cells. Failure to connect MLI inverter system batteries to an energized charging circuit within 90 days from the date of shipment will void the battery warranty.

#### **DANGER: Explosive - Can Cause Blindness or Other Severe Injuries**

Every type of battery can produce hydrogen gas, even sealed, maintenance-free batteries. The gas is vented through the vent caps and into the air. Do not allow smoking, sparks, or flames in battery storage location because hydrogen is concentrated under the vent cap of each cell of the battery. Hydrogen is highly explosive, and is hard to detect because it is colorless, odorless, and lighter than air.

### INSTALLATION REQUIREMENTS

---

#### Operating Environment

Install the MLI inverter system in a clean, cool, dry place with normal ventilation for human habitation and in such a location to hamper vandalism but allow easy access for testing and maintenance.

#### Operating Temperature:

MLI inverter systems with sealed lead calcium batteries are UL Listed for 20°C to 30°C (68°F to 86°F) operation. MLI inverter systems with NiCad batteries are UL Listed for 0°C to 50°C (32°F to 122°F) operation.

Battery performance and service life is maximized if the operating temperature is maintained at 25°C (77°F).

#### Temperature Effect on Lead Calcium Battery Performance:

Lead Calcium batteries will be less efficient at temperatures below 20°C (68°F), and high temperatures will reduce battery life. Typically, at 35°C (95°F), battery life will be half of what it would be at normal temperature of 25°C (77°F). At 45°C (113°F), battery life will be one-fourth of normal.

#### Temperature Effect on NiCad Battery Performance:

NiCad batteries will provide their full rated capacity throughout their useful life when operated within a range of 0°C to 50°C (32°F to 122°F).

#### Ventilation:

The air around the unit must be clean, dust-free, and free of corrosive chemicals or other contaminants. Do not place the MLI inverter system or batteries in a sealed room or container.

**CAUTION:** Never install batteries in a sealed room or enclosure.

#### High Altitude Operation:

The maximum operating temperature drops 1°C per 300 meters (2°F per 1000 feet) above sea level. Maximum elevation is 3000 meters (10,000 feet).





# MLI Series

## Installation Instructions

### CABINET MOUNTING

---

#### Tools Required

##### The following tools are required to install the system:

Socket set, Phillips screwdriver, diagonal wire cutters, long nose pliers, electrical tape, digital Volt-Ohm meter, safety glasses with side shields, small punch (knockout removal), hammer, electric drill, wood or masonry bits, level.

#### Mounting Hardware

Mounting hardware is not provided. Care should be taken when selecting mounting hardware to assure that it is the proper type for the application and sized to safely support the system's full weight when installed, assuring safe and secure attachment of system to wall surface or building structures. For ease of installation, the factory recommends that the head size of mounting screws or bolts be small enough to pass through the keyhole knockouts provided for mounting. This will allow the unit to be hung on partially installed mounting hardware and facilitate easy cabinet removal if ever necessary.

#### Knockout Locations

All models provide knockouts on the top and sides of the unit. Additional entry points, if required can be added using a metal punch. Do not drill into the cabinet, as metal filings can cause short circuits and damage the equipment.

**NOTE:** Consider unit knockout locations prior to mounting unit. Allow room for easy routing of conduit to entry point.

#### Cabinet Mounting - Surface Mount (SM) Models

1. Remove cover and any packing material inside unit housing that may have been used for shipping purposes.
2. Remove the appropriate knockouts, 7/8" diameter, on the top and/or right-hand sides of the unit housing to facilitate conduit attachment. Also remove keyhole knockouts in the upper corners on the back of the housing.
3. Secure housing to mounting surface through both keyhole knockouts provided using mounting hardware (not supplied) sized appropriately to support the unit weight.

#### Cabinet Mounting - Recessed Mount (RM) Models

1. Remove cover and any packing material inside unit housing that may have been used for shipping purposes.
2. Remove the appropriate knockouts, 7/8" diameter, on the top and/or right-hand side of the unit housing to facilitate conduit attachment. Also remove the appropriate round knockouts, 5/16" diameter, which are located on all sides of unit housing. Specific knockout requirements are dictated by mounting orientation of unit (vertical or horizontal) and location of wall studs and /or other support members.
3. Secure housing to support members through round knockouts using mounting hardware (not supplied) sized appropriately to support the unit weight.

**IMPORTANT:** Unit should be so positioned that the cabinet extends between 3/8" and 3/4" beyond the finished wall surface after installation.

4. Prior to final attachment of unit cover, the LED indicator panel assembly position must be adjusted to sit flush against inside surface of cover after attachment. This is accomplished using the (2) 8-32 hex nuts on the indicator assembly.

#### Cabinet Mounting - Ceiling T-Grid Mount (TM) Models

1. Remove cover and any packing material inside unit housing that may have been used for shipping purposes.
2. Remove the appropriate knockout(s), 7/8" diameter, located on either side of unit housing to facilitate conduit attachment.

**IMPORTANT:** Take care to remove only the knockouts required for utility connection. Removal of knockouts if unused and left open will void the plenum rating of the unit.

3. Mount the unit securely in place between T-Grid members.

**NOTICE:** Safety chain or cable, rated 50 pound minimum working load, 250 pound minimum breaking strength is required to hang the unit in a T-Grid system. Failure to correctly install unit will cause an unsafe condition!



### AC CONNECTIONS

#### CAUTION:

- All MLI inverter system units contain hazardous AC and DC voltages. Because of these voltages, a qualified electrician must install the MLI inverter system, AC line service, and batteries. The electrician must install the AC line service according to local, state and NEC codes and must be familiar with batteries and battery installation.
- Before installing, maintaining, or servicing the unit, always remove or shut off all sources of AC power to the MLI inverter system. Disconnect the unit battery leads to make sure the unit will not supply output voltage. Turn the AC line input circuit breaker OFF at the service panel.
- Whenever AC and/or DC voltage is applied, there will be AC voltage inside the MLI inverter system unit; the unit can supply power from AC line or from its batteries. To avoid equipment damage or personal injury, always assume that there may be voltage inside the MLI inverter system.
- Remove rings, watches, and other jewelry before installing the AC wiring. Always wear protective clothing and eye protection and use insulated tools when working near batteries. Whenever servicing an energized unit with the inside panel open, electric shock is possible; follow all local safety codes. **TEST BEFORE TOUCHING!**
- To reduce the risk of fire or electric shock, install the MLI inverter system and the batteries in a temperature-controlled and humidity-controlled indoor area free of conductive contaminants. See the Installation Requirements section on page 4 for operating environment specifications.

#### AC Wiring Preparations

1. Remove the system's front cover.
2. Make sure the MLI inverter system input and output voltages are correct for the particular application. Remember that the MLI system provides single-phase power only.
3. The input circuit breaker in the input service panel provides the means for disconnecting AC to the MLI inverter system. Only authorized persons shall be able to disconnect AC to the unit. (See NEC 700-20 and 700-21.)

**CAUTION:** To prevent electrical shock or equipment damage, for all units, make sure the MLI battery is disconnected and the AC input circuit breaker at the service panel is OFF before making AC connections to the MLI inverter system.

4. If not previously done, remove cabinet knockouts for AC Input and AC Output as described in the Cabinet Mounting section on pages 5 and 6 depending on mounting method.

**CAUTION:** Do not drill the cabinet; drill filings may damage the unit and prevent it from operating. If larger knockouts are needed, use a chassis punch to enlarge the appropriate knockout. Do not add additional or unnecessary knockouts.

5. Install the input and output conduits.
6. Run the AC Input service conductors and AC Output conductors through separate conduits. MLI inverter system emergency output circuits shall be installed in dedicated conduit systems and not shared with other electrical circuits as described in NEC 700-9(b).

MLI models can be configured for either 120VAC or 277VAC input connections, as well as various modes of output operation as described in this section. Refer to the appropriate wiring diagrams to properly connect the utility AC power, fixtures and external switching or dimming device (where applicable). Perform all wiring procedures in accordance with applicable codes.

#### AC Input Voltage Selector Plug Installation

MLI inverter systems may be operated from either 120VAC or 277VAC power sources. Determine the actual AC input line voltage and install the provided Voltage Selector Plug in the position next to the system terminal block that matches the line voltage potential as shown in the illustration below. (Fig. 1)

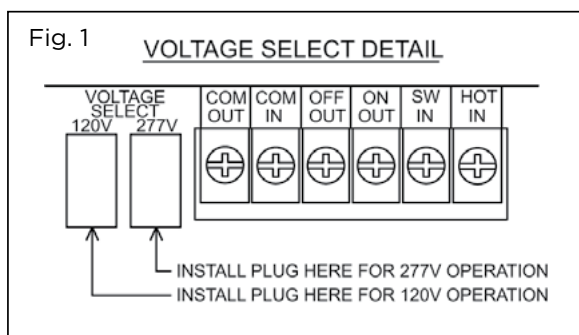

**CAUTION:** Failure to install the Voltage Selector Plug will prevent system operation. Installing the Voltage Selector Plug in the position that does not match the actual AC input line voltage will damage the unit, void the warranty, and may cause a dangerous or unsafe condition.

### AC CONNECTIONS , CONTINUED

#### AC Input/Output Wiring Connections to Terminal Block

Depending on how the fixture load is to be operated, wire the system as described below:

Normally-On Operation - Connected fixture(s) remain illuminated in AC and emergency modes. See Fig. 3.

Normally-Off Operation - Connected fixture(s) illuminate only upon loss of utility AC power. See Fig. 4.

Normally-On and Normally-Off Operation - A combination of the operating modes described above. See Fig. 5.

Switched Load Operation - Single Circuit - Connected fixture(s) can be externally switched and will illuminate upon loss of utility AC power regardless of external switch position. See Fig. 6.

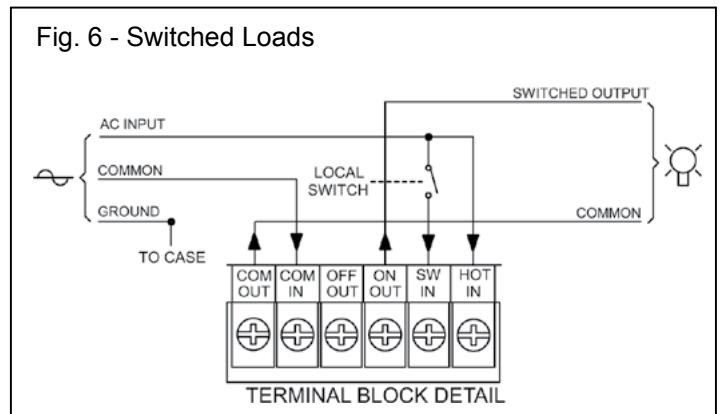
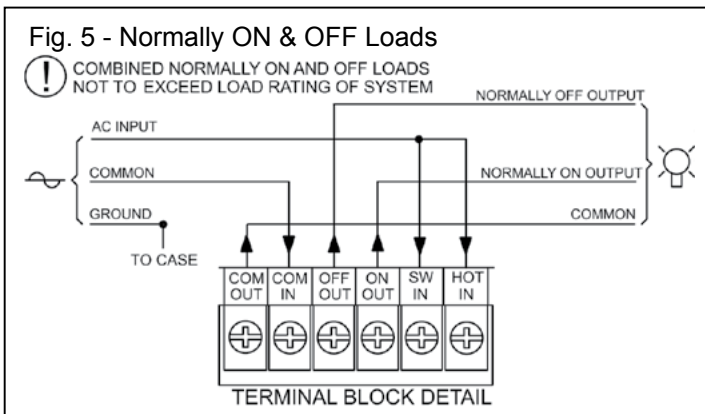
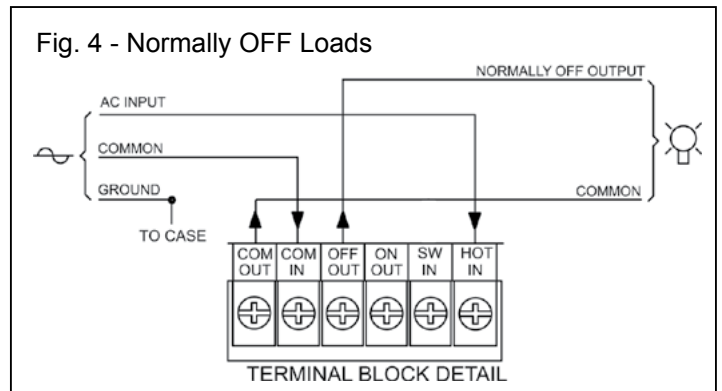
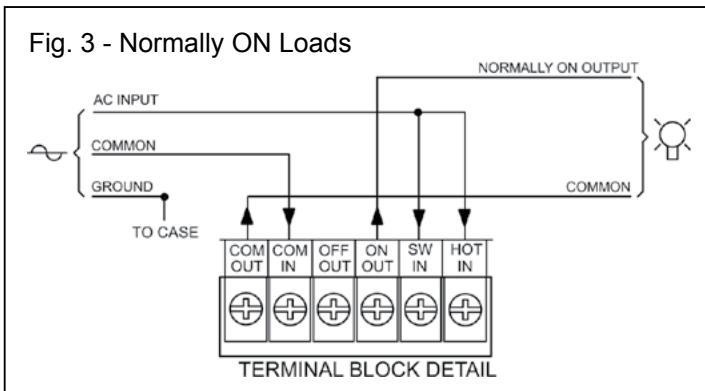
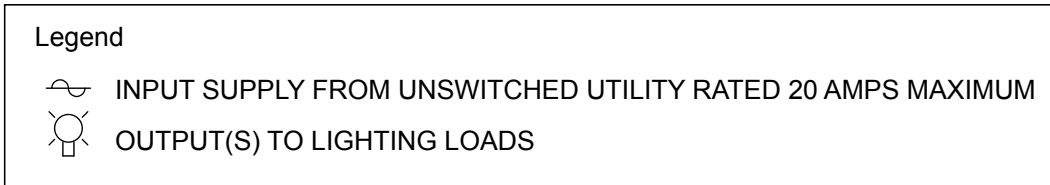



# MLI Series

## Installation Instructions

### BATTERY INFORMATION

---

#### Important Safety Precautions

##### The installer must take these precautions:

- Wear protective clothing, eyewear, rubber gloves and boots. Batteries contain corrosive acids or caustic alkalis and toxic materials and can rupture or leak if mistreated. Remove rings and metal wristwatches or other metal objects and jewelry. Do not carry metal objects in pockets where the objects can fall onto the batteries or into the MLI inverter system.
- Tools must have insulated handles so that they will not short battery terminals. Do not allow a tool to short a battery terminal to another battery terminal or to the cabinet at any time. Do not lay tools or metal parts on top of the batteries, and do not lay any objects where they could fall onto the batteries or into the cabinet.
- Install the batteries as described in this manual. When connecting cables, never allow a cable to short across a battery's terminals or to the cabinet.
- Keep the cable away from any sharp metal edges.
- Install the battery leads so they cannot be pinched by the MLI inverter system cover/door.
- Where conductors may be exposed to physical damage, protect conductors in accordance with NEC requirements.
- Full voltage and current are always present at the battery terminals. The batteries used in this system can produce dangerous voltages, extremely high currents, and possible risk of electric shock. Batteries may cause severe injury if the terminals are shorted together or to ground (earth). Be extremely careful to avoid electric shock and burns caused by contacting battery terminals or shorting terminals during battery installation. Do not touch uninsulated battery terminals.
- A qualified electrician who is familiar with battery systems and required precautions must install and service the batteries. Any battery used with this unit shall comply with the applicable requirements for batteries in the standard for emergency lighting and power equipment, UL 924. Cabinets are designed to be used with, and batteries must be replaced by identical cells or a Manufacturer approved equivalent. If using substitute batteries not supplied by the Manufacturer, the unit's UL listing will be void, and the equipment may fail to perform properly. The installation must conform to national and local codes as well. Keep unauthorized personnel away from batteries.

#### Tools

The following tools are required to install the system batteries: long nose pliers, digital Volt-Ohm meter, safety glasses.

**CAUTION:** Always use insulated tools for battery installation.

#### Battery Installation and Connection

1. Lead-Calcium Battery Models: MLI 32 and MLI 55 are supplied with a single 12VDC Lead Calcium battery. To install the unit battery, place the battery within the system housing and connect the black battery negative fly lead to the battery's black (B-) terminal. Connect the red battery positive fly lead to the battery's red (B+) terminal.
2. Nickel Cadmium Battery Models: MLI 20N and MLI 35N are supplied with a single 12VDC Nickel Cadmium battery. To install the unit battery, place the battery within the system housing and connect the black battery negative fly lead to the battery's black (B-) lead wire. Connect the red battery positive fly lead to the battery's red (B+) lead wire.

#### Battery Voltage Check

Using a digital volt-ohm meter, check for correct nominal battery voltage between DC Input NEG and POS wires. Voltage reading should be  $\pm 10\%$  of system's nominal 12VDC operating voltage.







# MLI Series

## Installation Instructions

### FINAL INSTALLATION CHECKLIST

---

**IMPORTANT:** Before proceeding to the System Start-Up Procedure section, complete the Final Installation Checklist below:

1. Ensure the MLI cabinet is securely fastened to a wall or other structure.
2. Ensure that the input circuit breaker in the building service panel serving as the AC disconnect to the MLI system is in the OFF position.
3. Check for proper ground connections in the MLI unit cabinet.
4. Check for any loose wiring connections in the MLI unit cabinet.
5. Check that correct nominal battery voltage (12VDC) is present in the MLI unit between the battery's NEG and POS terminals.
6. Verify AC Input Voltage Selector Plug are installed and in the proper position to accept the AC input line voltage for the system voltage configuration.

**CAUTION:** Failure to install the Voltage Selector Plug will prevent system operation. Installing the Voltage Selector Plug in the position that does not match the AC input line voltage will damage the unit, void the warranty, and may cause a dangerous or unsafe condition.

### System Start-Up Procedure

**IMPORTANT:** The MLI inverter system is a sophisticated electronic backup power supply. Care must be taken to follow the steps below in their exact sequence. Failure to do so may result in possible equipment failure.

**CAUTION:** Familiarize yourself with the shut down procedure in the Maintenance - Safe Shut Down Procedure section on page 11 before proceeding with the MLI system start-up.

1. Apply utility AC power to the system by turning the branch circuit breaker in the main power panel to the ON position.
2. Observe the LED Status indicators and verify the following:
  - a. AC ON indicator (red LED) is illuminated (indicates AC utility power is available to unit).
  - b. CHG ON indicator (green LED) is illuminated (indicates battery is connected and charger is operational).
3. Verify Normally-On fixtures or switched fixtures (where applicable) are illuminated (local fixture switch must be in ON position).

### System Test

**Momentarily push TEST switch and verify the following:**

1. INV ON status indicator (yellow) illuminates (indicates inverter is operational).
2. Normally-On, Normally-Off and Switched fixtures are illuminated (where applicable).





# MLI Series

## Installation Instructions

### MAINTENANCE

---

#### Safe Shut Down Procedure

**CAUTION:** To avoid possible equipment damage or personal injury, assume that there is AC voltage present inside the MLI inverter system unit any time AC input power or DC battery voltage is applied. The inverter is capable of providing output voltage from the batteries even when there is no AC input line voltage. When AC input voltage is present, the unit can provide output voltage even when the batteries are disconnected.

Do not touch components inside the unit. DC voltage is always present at the batteries and battery cables.

#### Final Shut Down Procedure

1. Open the unit's front access panel.
2. Disconnect the unit battery leads to make sure the unit will not supply output voltage.
3. Place the AC Input circuit breaker at the service panel in the OFF position.

**CAUTION:** HAZARDOUS ENERGY IS STORED IN CAPACITORS INSIDE THE MLI UNIT. AFTER TURNING OFF SWITCHES, ALLOW 5 MINUTES FOR CAPACITORS TO DISCHARGE BEFORE ATTEMPTING ANY SERVICE PROCEDURES.

4. If the service technician does not need to access the inside of the unit, keep the unit's front cover/door closed.
5. If the unit will be shut off for an extended period of time, recharge battery every 60 to 90 days.

**CAUTION:** The battery will be damaged and the warranty voided if not routinely recharged.

**NOTE:** To turn power back on, follow the steps outlined in the System Start-Up Procedure section on page 10. Be sure to complete all of the steps to assure the unit will operate properly.

#### Routine System Maintenance

The MLI inverter system unit is designed to provide years of trouble-free operation. The unit does require some routine attention to assure peak performance. The manufacturer recommends a preventative maintenance check be performed by a qualified service technician at least every six months. The technician must observe important safety precautions while performing the following recommended tasks:

- Inspect and clean the unit interiors;
- Inspect all batteries for leaks, case swelling, or terminal corrosion;
- Perform an emergency operation test to check operation of all critical connected loads

#### Manual Routine Inverter Tests

NFPA101 requires that Emergency Lighting Equipment be tested on a monthly basis for a period of at least 5 seconds, and a minimum of 90 minutes once a year. We strongly recommend these guidelines be followed to ensure system readiness, and to prolong battery life. The MLI system was designed with a front panel test switch to facilitate monthly testing. Simply depress the button and hold to test the inverter at any time. Once released, the MLI will revert back to standby operation. For annual 90-minute discharge or other prolonged tests, simply turn off the AC Input breaker at the service panel.





# MLI Series

## Installation Instructions

### ROUTINE BATTERY INSPECTION AND MAINTENANCE

---

#### Sealed Lead-Calcium Batteries

Maintenance-free cells are the most common type of battery used today in standby equipment. By design, it is as maintenance-free as a battery can be. It is recommended, however, that some simple steps be taken to increase system life and maximize reliability:

1. A quarterly visual check of the battery should be conducted to look for deformities in the battery case, electrolyte leakage, and/or terminal corrosion. Any batteries with these conditions are defective and should be replaced. Any corroded terminals found, regardless how slight, are to be cleaned at once to prevent system failure.
2. Once a year, all battery connections should be checked for tightness and cleaned and retightened, as necessary.

#### Battery Replacement Procedure

##### WARNINGS:

- Always use the same quantity and type of battery as replacements.
- Substituting batteries not supplied by the Manufacturer will void the UL listing of the system and may cause equipment failure. To ensure the superior performance of your MLI inverter system and to maintain proper charger operation, replace spent batteries only with those having the same part number, voltage, and ampere-hour rating as the original batteries.
  3. Follow the proper shut down procedure as described in the **Maintenance - Safe Shut Down Procedure section on page 11.**
  4. Disconnect the battery Positive red (B+) and Negative black (B-) connectors.
  5. Remove the battery from the cabinet.
  6. Install the new battery following the instructions outlined in the **Battery Information - Battery Installation and Connection section on page 9.**

#### Battery Disposal

##### WARNINGS:

- Do not dispose of batteries in a fire; the batteries could explode.
- Do not open or mutilate batteries.
- Released electrolyte is highly toxic and harmful to the skin and eyes.

**CAUTION:** Batteries contain lead or cadmium, depending on model. Many state and local governments have regulations about used battery disposal. Please dispose of the batteries properly.



### INSTRUCTIONS FOR SELF-TEST/SELF-DIAGNOSTICS

Once the unit is properly installed in accordance with the installation instructions and AC power is supplied to the unit, the dual color (SDT STATUS) LED indicator will illuminate, followed by the amber (INV ON) LED indicator. The dual color LED indicates the unit's status. A steady GREEN LED indicates normal service; A blinking GREEN/RED LED indicates the battery is charging; A BLINKING RED LED (in different combinations) indicates a service alert. Refer to Table 3 below for details. During loss of normal utility power, the dual color LED will not be illuminated. The AMBER (INV ON) LED indicator will be illuminated only during inverter operation initiated by the loss of utility power or during any manual or automatic self-test.

#### Self-Diagnostic Service

**The self-diagnostic function is factory preset and performs the following:**

1. Monitoring of battery, battery charger, and connected loads.
2. Self-testing and a (30) second battery discharge once every (30) days, after normal utility power has been supplied for a minimum of (96) hours.
3. Self-testing and a (30) minute battery discharge once every (180) days, after normal utility power has been supplied for a minimum of (96) hours.
4. Self-testing and a (90) minute battery discharge once every (365) days, after normal utility power has been supplied for a minimum of (96) hours.

**Table 3 - Service Indication**

LED Indicator	Status
GREEN steady	Normal service
RED/GREEN blinking	High Charge enabled
GREEN blinking	Test Mode enabled
One blink RED/pause	Battery Charger fault
Two blinks RED/pause	Battery fault
Four blinks RED/pause	Lamp/Load fault

**Table 4 - Manual Testing**

The unit also provides for manual testing by pushing the TEST button in a specific pattern:

Action	Reaction and LED Indication
Push test switch Once (within (2) seconds)	(30) second test: One blink GREEN/pause
Push test switch Twice (within (2) seconds)	(30) minute test: Two blink GREEN/pause
Push test switch Three times (within (2) seconds)	(90) minute test: Three blink GREEN/pause
Push test switch and hold for (3) seconds	Cancel test
Push test switch and hold for (6) seconds	System reset