

LED Pendant Mounted Luminaire

Installation Instruction Sheet

Linear Fixtures

INSTALLATION INSTRUCTIONS FOR JOINING AND SUSPENDING FIXTURES

WARNING

To reduce the risk of death, injury or property damage from fire, electric shock, cuts, abrasions, falling parts and other hazards:

- Service of the equipment must be performed by qualified service personnel.
- Installation and maintenance must be performed by a person familiar with the construction and operation of this product and any hazards involved. All applicable codes and ordinances must be followed.
- Read this document before installing, servicing or maintaining this equipment. These instructions do not cover all installation, service and maintenance situations. If your situation is not covered, or, if you do not understand these instructions or additional information is required, contact your local distributor.
- Read and follow all warnings and instructions provided by the lamp manufacturer.

WARNING

- Before installing, servicing or maintaining this equipment, follow these general precautions. To reduce the risk of electrocution:
- Make sure the equipment is properly grounded.
- Always de-energize the circuit and/or equipment before connecting to, disconnecting from or servicing the equipment.

To prevent luminaire row from over-current:

- By adding the input current of each luminaire section marked on the luminaire, the total current per power feed must not exceed the maximum line wire amperage marked on the luminaire and the power feed cord/wire amperage rating whichever is the least.

To reduce the risk of fire:

- Keep material away that can burn from hot LEDs.
- Make sure LED boards are correctly installed.
- Use supply conductors with a minimum installation temperature rating as specified on equipment.

To reduce the risk of personal injury from cuts, abrasions or falling parts:

- Wear gloves to prevent cuts or abrasions from sharp edges when removing from carton, handling and maintaining this equipment.
- Do not use abrasive materials, glass cleaners or other solvents on reflector or lens. These substances may damage equipment and cause parts to eventually break and fall.
- Do not install a damaged fixture.

LED Pendant Mounted Luminaire

Typical Mounting Configurations

Linear Fixtures

Drop Ceiling System (Non Feed)

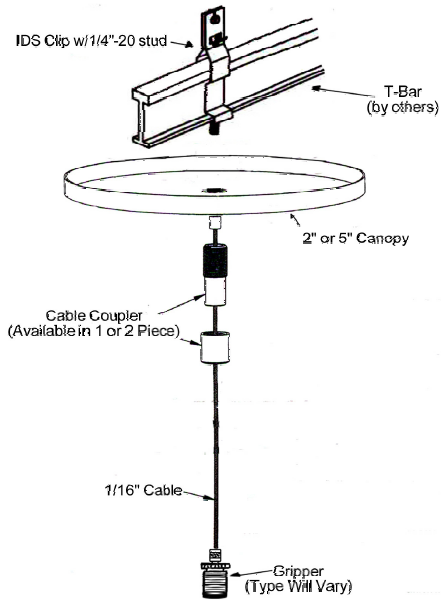

Drop Ceiling System (Feed)

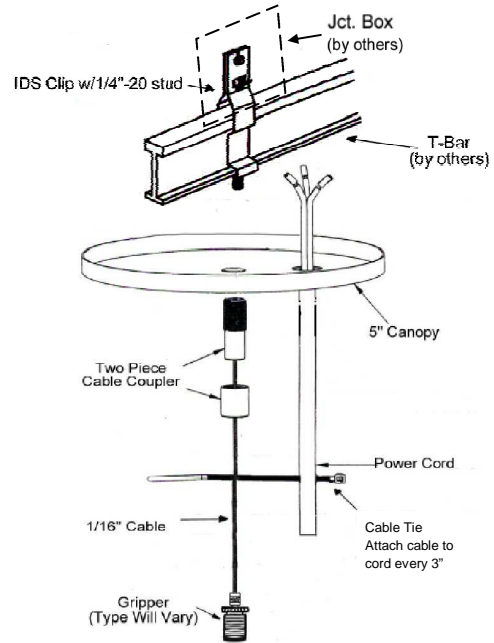

Hard Ceiling System (Non Feed)

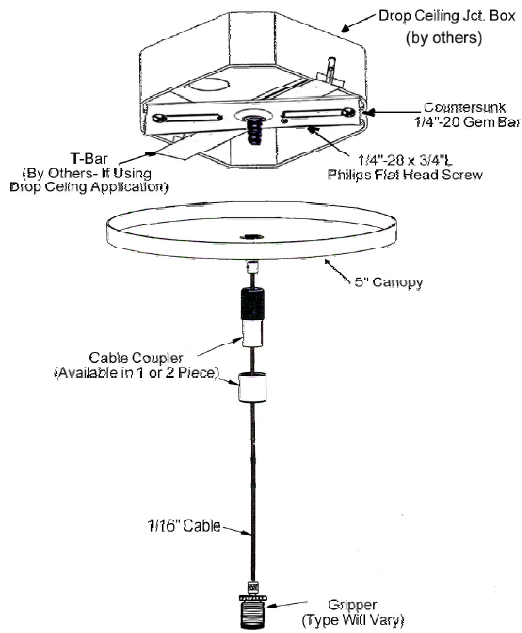

Hard Ceiling System (Feed)

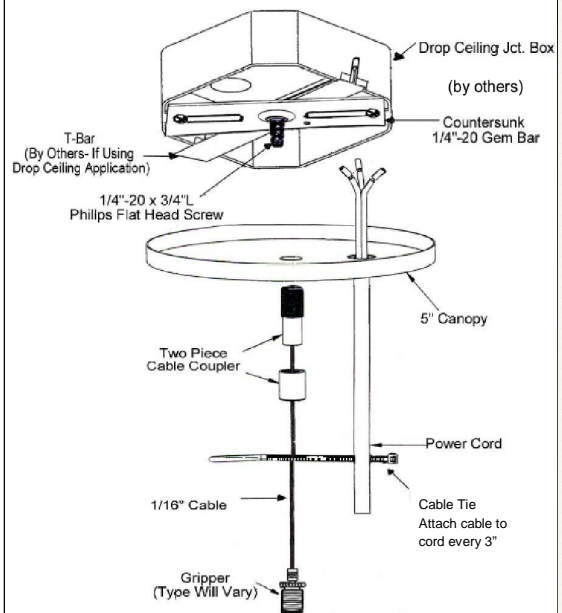

LED Pendant Mounted Luminaire

Installation Instruction Sheet

Linear Fixtures

INSTALLATION INSTRUCTIONS FOR POWER FEED

Insert power cord through feed hole on the first fixture and plug to through harness connectors. Plug (supplied) any unused feed holes.

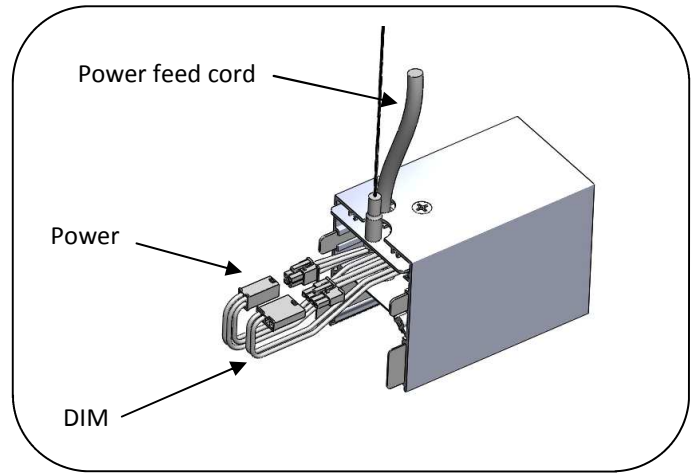

For special circuitry consult factory	
LINE WIRE COLOR	CIRCUIT DESCRIPTION
BLK	CIRCUIT A—HOT
WHT	CIRCUIT A & B— NEUTRAL
RED	CIRCUIT B— HOT
GRN	GROUNDING
VLT	DIMMING CONTROL 1
GRY	DIMMING CONTROL 2
ORG	EHS or EHF—HOT
WHT/ORG	EHS or EHF— NEUTRAL

POWER FEED CORD COLOR	
14x3 BLK/WHT/GRN	CIRCUIT A & EMERGENCY
14x4 BLK/WHT/GRN/RED	CIRCUIT B, OR CIRCUIT A W/ EHS
18x5 BLK/WHT/GRN/VLT/GRY	CIRCUIT A & EMERGENCY & DIM

General Wiring Diagram

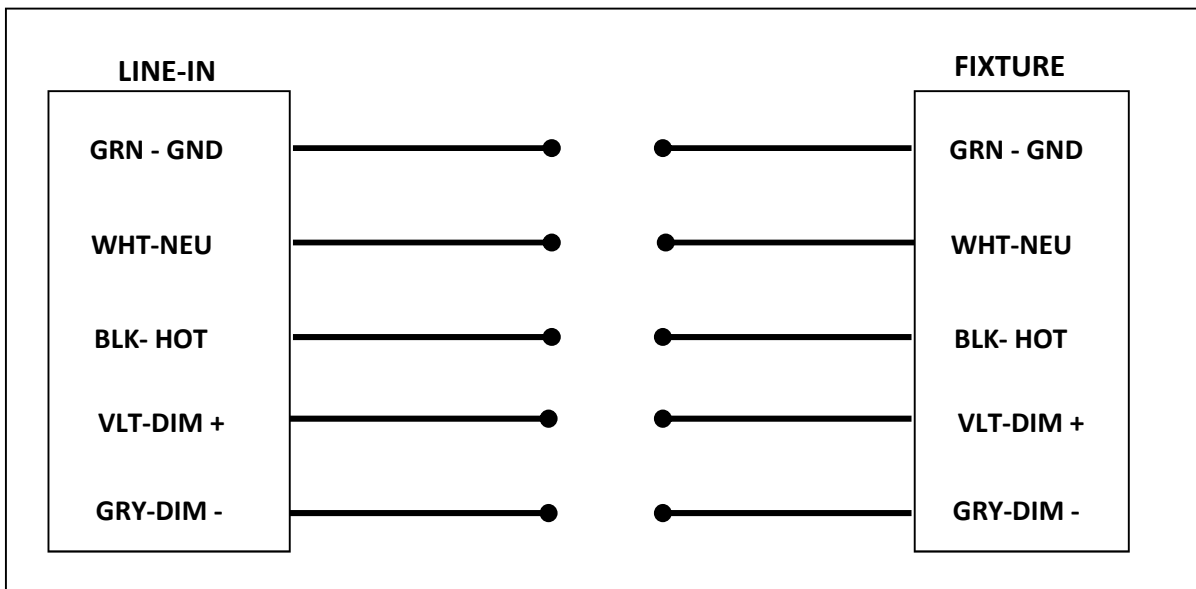

LED Pendant Mounted Luminaire

Linear Fixtures

INSTALLATION INSTRUCTIONS FOR JOINING AND SUSPENDING FIXTURES

Use hanger bracket located at the end of the fixture to support fixture.

Screw cable gripper/stem into the outside thread position of hanger at the end of a row *OR* in the middle thread position if joining fixtures together.

Adjust fixture length from ceiling with cable gripper.

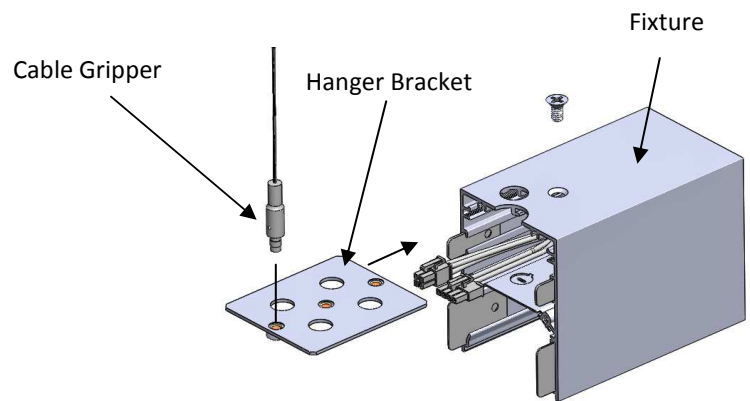

Use provided flathead screws to secure hanger bracket to fixture.

Remove power and dimming harness connectors from the fixture to attach to power cord. (Tuck in fixture)

Guides are used to align fixtures. Slide fixtures together and fasten supplied flathead screw to bracket.

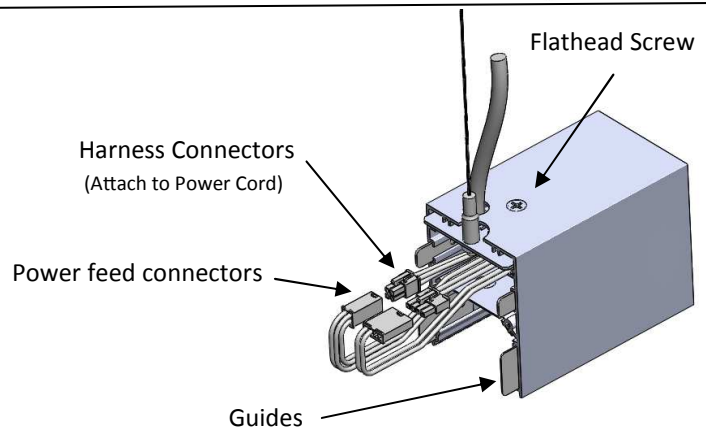

For row mounting fixtures attach male end of harness to female end of harness.

Small lens section is centered between fixtures to avoid light leak at lens ends.

Fasten flathead screws on each fixture.

Fasten reflector tabs down with supplied screws to the joining fixture.

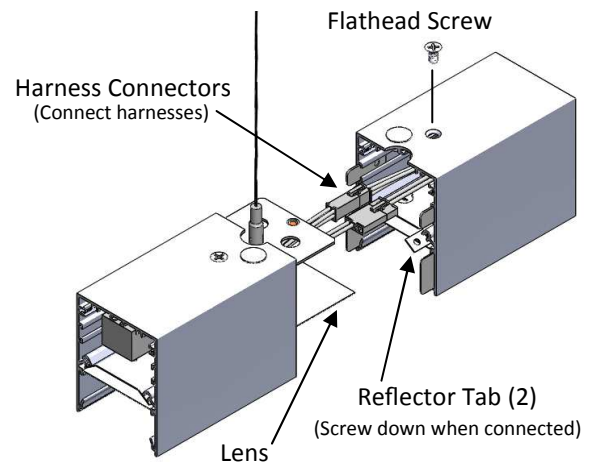

Tuck in harness at the end of rows and attach endcaps using supplied screws.

Fold reflector tabs up or break off at the end of rows.

Attach fixture lens.

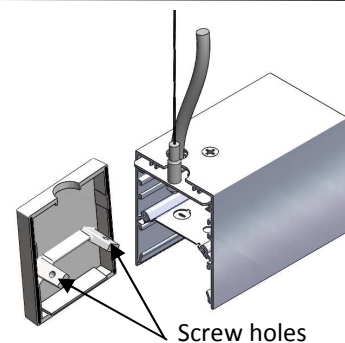

LED Pendant Mounted Luminaire

Linear Fixtures

INSTALLATION INSTRUCTIONS FOR JOINING AND SUSPENDING CORNER

Support the fixture using the hanger brackets located at the end of the fixture or optional bracket located in the center of the corner to support fixture.

Adjust fixture length from ceiling with cable gripper.

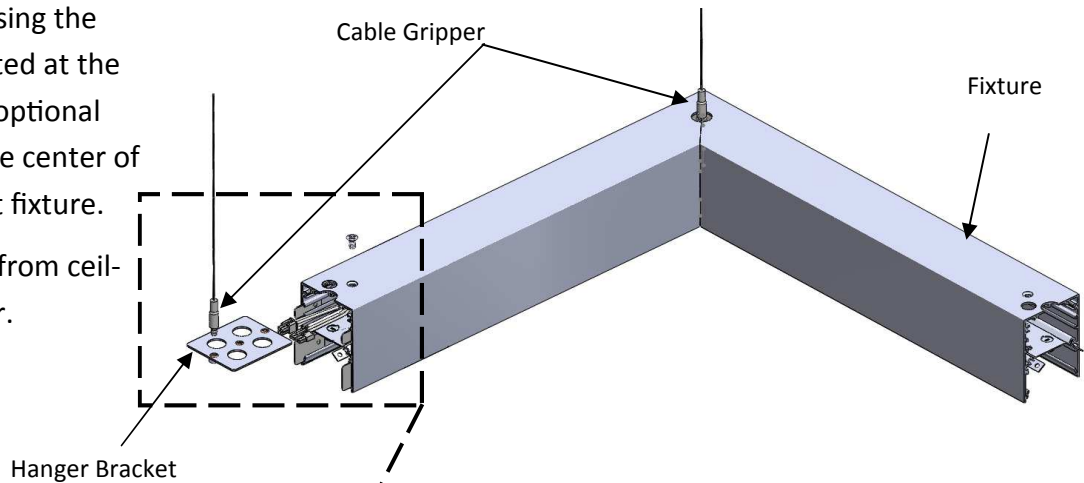

Use provided flathead screws to secure hanger bracket to fixture.

Remove power feed and dimming harness connectors from the fixture to attach to power cord. (Tuck in fixture)

Guides are used to align fixtures. Slide fixtures together and fasten supplied flathead screw to bracket.

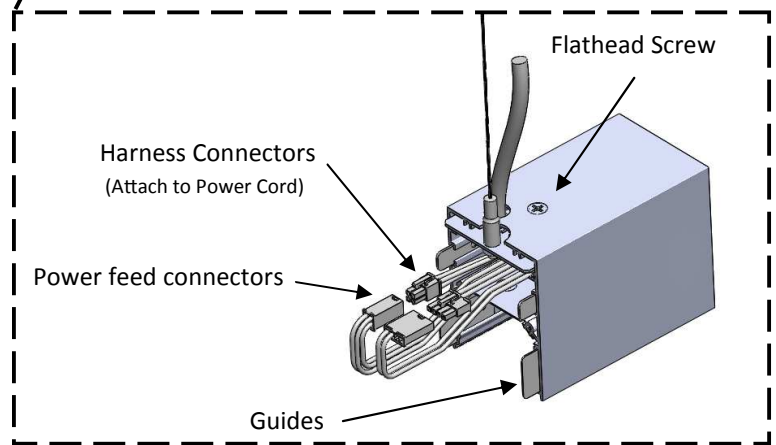

Note: If the harness needs reversed for a left hand corner, use the 4" adapter harnesses provide in the hardware kit.

To connect to joining fixture attach male end of harness to female end of harness as shown.

Small lens sections is centered between fixtures to avoid light leak at lens ends.

Fasten flathead screws on each fixture.

Fasten reflector tabs down with supplied screws to the joining fixture.

