

Catalog # :

Project :

Prepared By :

Date :



TLFL Series 2nd Gen Large LED Flood Light

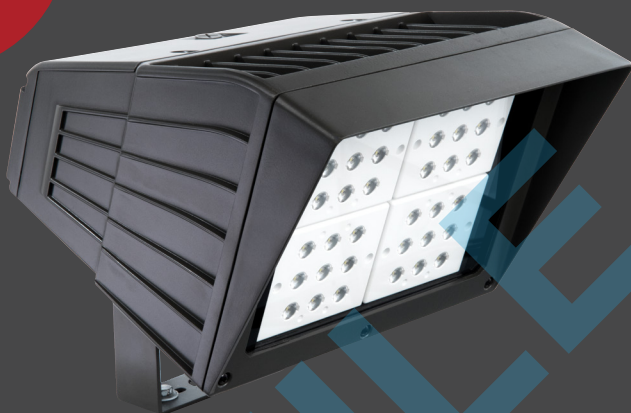

LSI 2nd Generation flood lights are the most powerful LED flood lights available in the market today. They use optical grade individual acrylic lenses which deliver more lumens to the desired target, guaranteeing more footcandles, less glare and less wasted light.

Features & Specifications

Optical System

- LSI flood lights utilize individual lenses for maximum light intensity.
- Lenses are made of optical grade acrylic guaranteeing more footcandles, less glare and less wasted light.
- Minimum CRI of 70

Electrical

- High-performance driver features over-voltage, under voltage, short-circuit and over temperature protection.
- 0-10 volt dimming (10% - 100%) standard.
- Standard Universal Voltage (120-277 Vac) Input 50/60 Hz
- L70 Calculated Life: >100k Hours
- Total harmonic distortion: <20%
- Power factor: >.85
- Input power stays constant over life.
- Driver Off-State Power is 0 watts.
- Components are fully encased in potting material for moisture resistance. Driver complies with FCC standards. Driver and key electronic components can easily be accessed.
- Minimum 2.5kV surge rating

Construction

- Rigid Precision Die cast-aluminum housing for durability and consistency.
- Vertical fins serve as a heat sink and resist accumulation of dust and debris.
- Separate driver compartment for cooler operation and longer driver life. Removable back panel offers easy access to the driver compartment.
- The Patent Pending thermal stacking heat removal technology extracts heat from within the housing moving it away from LEDs and integral components.
- Luminaire is proudly manufactured and tested in the U.S.
- Fixtures are finished with LSI's DuraGrip® polyester powder coat finishing process. The DuraGrip finish withstands extreme weather changes without cracking or peeling. Other standard LSI finishes available. Consult factory



Dimensions Design is Protected by US Patent D740,997

Weight

- 20 lbs. (with Trunnion)
- 21 lbs. (with Slipfitter)

EPA

1.00

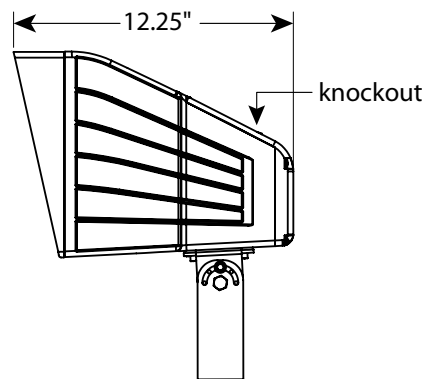
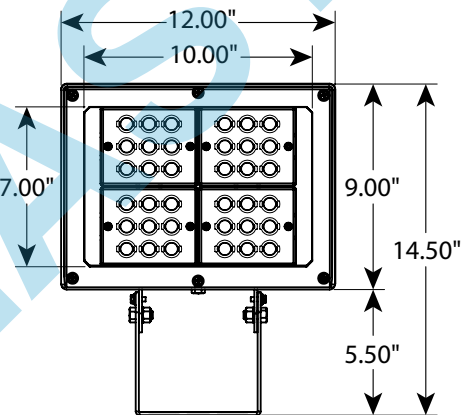



TLFL Series 2nd Gen Large LED Flood Light

Features & Specifications (Cont.)

Controls

- Optional electronic button Photocontrol.
- Apertures for field or factory installed photocontrol.

Warranty

- LSI LED Fixtures carry a 5-year warranty.
- 1 Year warranty on optional Button Photocell.

Listings

- Listed to UL 1598 and UL 8750.
- CSA Listed
- RoHS Compliant.
- American Recovery and Reinvestment Act Funding Compliant.
- Suitable For Wet Locations
- DesignLights Consortium qualified luminaire, eligible for rebates from DLC member utilities.

Finishes

- Bronze is standard. Consult factory for pricing and lead time for other options.

Performance

Lumens	3000K		4000K		5000K		Wattage
	Delivered Lumens	Efficacy	Delivered Lumens	Efficacy	Delivered Lumens	Efficacy	
17L	16140	101.82	16140	101.82	16465	103.3	158.52
20L	18160	96.64	19790	106.26	18768	100.4	187.91

Energy Savings

LED		HID			Annual Savings
Wattage	Annual Cost	Source Wattage	Total Wattage Used	Annual Cost	
159	\$71	250	285	\$150	\$79
188	\$83	400	458	\$226	\$155

DLC Listings

Lumens	3000K	4000K	5000K
	DLC Prod. ID	DLC Prod. ID	DLC Prod. ID
17L	PZ8EKYXG	PHJODWJO	P50J5DEO
20L	P5JX10BU	PN9MWIFS	PJEFMKGH

DesignLights Consortium qualified luminaires, eligible for rebates from DLC member utilities.

Mounting Detail

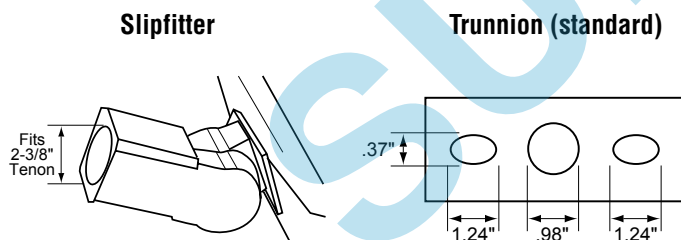

Luminaire Ordering Guide

TYPICAL ORDER EXAMPLE: **TLFL LED 17L UNV DIM 40 BZA**

Family Prefix	Lumen Package	Voltage	Dimming	Color Temp	Color Rendering	Finishes	Mounting	Options/Controls
TLFL LED - Large LED Flood Light	17L - 17,000 Lumens 20L - 20,000 Lumens	UNV - Universal (120V-277V) HV - 347-480V Universal Voltage	DIM - Dim to 10% (0 to 10V)	30 - 3000K 40 - 4000K 50 - 5000K	Blank - 70 Color Rendering Index	BZA - Bronze WHT - White BLK - Black	TR - Trunnion Mount SF - Slipfitter Mount	PC120 - 120V Button Photocontrol PC208-277 - 208-277V Photocontrol