



AirLink™ Wireless Hub
enabled by Lutron®



_____ Project name
_____ Prepared by
/ / Date

Catalog #: **ALWH FM/SM BACNET**
ALWH FM/SM
ALWH FM S/ALWH SM S

Part #: **649927/649928**
649923/649925
680086/680087

The wireless hub provides a connection point for devices such as the AirLink Powerpacks (dimming and switching), wireless fixture controllers, 20AMP plug load controllers, wireless switches, ceiling-mounted wireless occupancy sensors and daylight sensors.

Applications



Small offices



Conference rooms



Classrooms



Lounges

Features

- Communicates with controls using Lutron Wireless Clear Connect Technology (range radius of 71ft [22m])
- The ALWH FM/SM supports up to 700 devices and the ALWH FM S/SM S supports up to 75
- Distributed system architecture
 - Wireless switches and wireless sensors communicate directly with the load devices they control and must be located within 30ft (9m) of the device with which they are associated
- Supports timeclock events based on both sunrise and sunset or fixed time-of-day
- Multi-color LED displays what mode the hub is in
- Two Contact Closure Inputs for device integration by others including Title 24 Automatic Demand Response devices
- Web based software used for:
 - Setup and programming
 - Uses Lutron RF signal strength measurements to find devices nearby for quick association and programming without having to climb ladders
 - Dashboard of current status for control and monitoring of the system also shows current energy usage

- Username and password protected access
- Supports HTTPS
- Supported on most devices that use an HTML5 compliant browser (iOS, Android®, Windows®, Mac). Recommended configurations:

Device	OS Version	Browser
iPhone 6, iPhone 6 plus or newer	iOS 10.0	Safari
Samsung Galaxy S6®	Android® 6.0	Chrome®

- Connects directly to any smartphone, tablet or computer using built in Wi-Fi. 2.4 GHz 802.11b / g
 - Range radius of 71ft (22m)
 - WPA2 Security
- Ethernet 10 / 100 Mbps connection for:
 - Native BACnet (see Lutron P/N 369978 for PIC Statement) integration into Building Management Systems
 - Network multiple wireless hubs together as an independent system or for an existing building network

Certifications & Affiliations



Canada Industry Canada (IC)





Features (continued)

- Firmware upgradable for future features and security patches. Receive updates automatically (requires internet connection) or manually
- Flush-mount or surface-mount options available
- If using daylight sensors with multiple rows of fixtures that have different daylight responses, either one daylight sensor per row is required or individual fixture sensors and controllers must be used
- Measured energy data for wireless fixture controller accurate to ±2%, or 0.5W, whichever is higher. Calculated energy data for modules and dimmers or switches at 10% accuracy
- Create and edit areas and zones: enable and disable daylighting within areas, adjust daylighting and occupancy settings, and create occupancy groups
- Tune area light levels by trimming the high-end and low-end output to save energy
- Load shed configurable

Specifications

Regulatory Approvals

- COFETEL, IC and NOM-001
- cULus® Listed
- FCC approved. Complies with the limits for a Class B device, pursuant to Part 15 of the FCC rules

Environmental

Ambient Operating Temperature: 32°F to 104°F (0°C to 40°C), relative humidity less than 90% non-condensing; indoor use only

Ordering Information

Part #	Catalog #	Description
649927	ALWH FM BACNET	AirLink System – Wireless hub with BACnet - flush mount - 700 devices max
649928	ALWH SM BACNET	AirLink System – Wireless hub with BACnet - surface mount - 700 devices max
649923	ALWH FM	AirLink System – Wireless hub without BACnet - flush mount - 700 devices max
649925	ALWH SM	AirLink System – Wireless hub without BACnet - surface mount - 700 devices max
680086	ALWH FM S	AirLink System – Wireless hub without BACnet - flush mount - 75 devices max
680087	ALWH SM S	AirLink System – Wireless hub without BACnet - surface mount - 75 devices max

Mounting

- Wireless hub units should be mounted in the middle of non-metal ceiling tile or drywall, visible from inside the space
- Installation near metal, other than a junction box, may reduce RF range. Hub should be at least 12in (305mm) away from metal objects
- Use surface-mount version for mounting to hard or cement ceiling
- Power supply mounts to a standard 4in x 4in (101mm x 101mm) square junction box
- Power supply must be mounted within 100ft (31m) of the hub. Wiring should be 24AWG to 12AWG (0.2mm² to 2.5mm²)

Two Contact Closure Input Terminals

- Accepts only maintained inputs
- Off-state leakage current must be less than 100 µA
- Open circuit voltage: 24V , maximum
- Input wiring: 24AWG to 12AWG (0.2mm² to 2.5mm²)
- Contact Closure Inputs on multiple hubs can be wired in parallel. DO NOT wire inputs in parallel with other equipment as it can cause the inputs on either of the devices to falsely trigger
- To ensure proper operation of Contact Closure Inputs, a Lutron PS-J-20W-UNV power supply may not be used to provide power to more than one hub
- Inputs must be dry contact closure, solid state, open collector, or active-low (NPN) / active high (PNP) output.
 - Open collector NPN or active-low on-state voltage must be less than 2V and sink 3.0 mA.
 - Open collector PNP or active-high on-state voltage must be greater than 12V and source 3.0 mA.



Dimensions

Wireless Hub

Top View

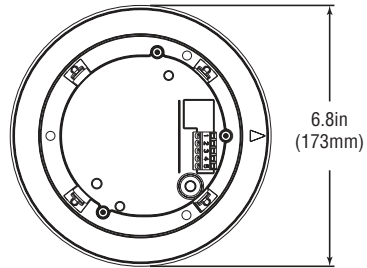

Side View

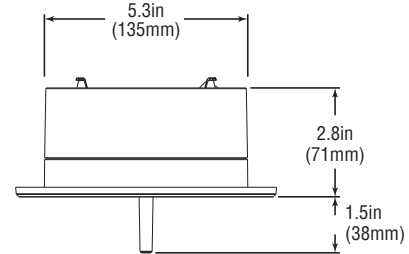

Flush-mount Adapter

Top View

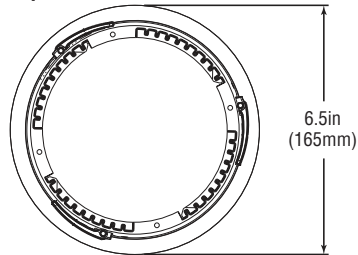

Side View



- Requires a 6in (153mm) hole to be cut in the ceiling for mounting

Surface-mount Adapter

Top View

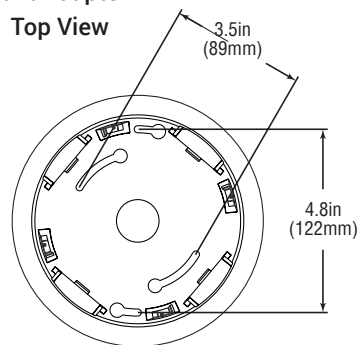

Side View

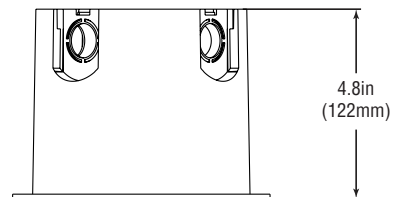

- Knockouts for 3/4in (19mm) conduit

Power Supply

Top View

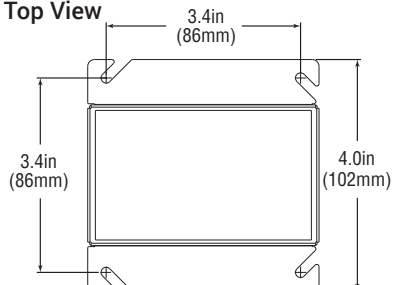

Side View

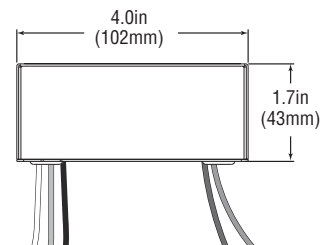



Range Diagram

All wireless devices to be associated to the wireless hub must be on the same floor and within 71ft (22m) of the hub.

Note: AirLink Wireless Hubs should be mounted greater than 10ft (3m) apart on the same floor.

Note: AirLink Wireless Hub hubs should be mounted greater than 10ft (3m) from a Wi-Fi router or access point.

Note: A corporate Wi-Fi network can interfere with the Wi-Fi on the wireless hub. If so, it is recommended to do one of the following:

- 1) Connect to the hub and change the Wi-Fi channel to one that isn't used by the corporate network, or
- 2) Connect the hub to the corporate network using the Ethernet connection on the hub and disable the hub's Wi-Fi

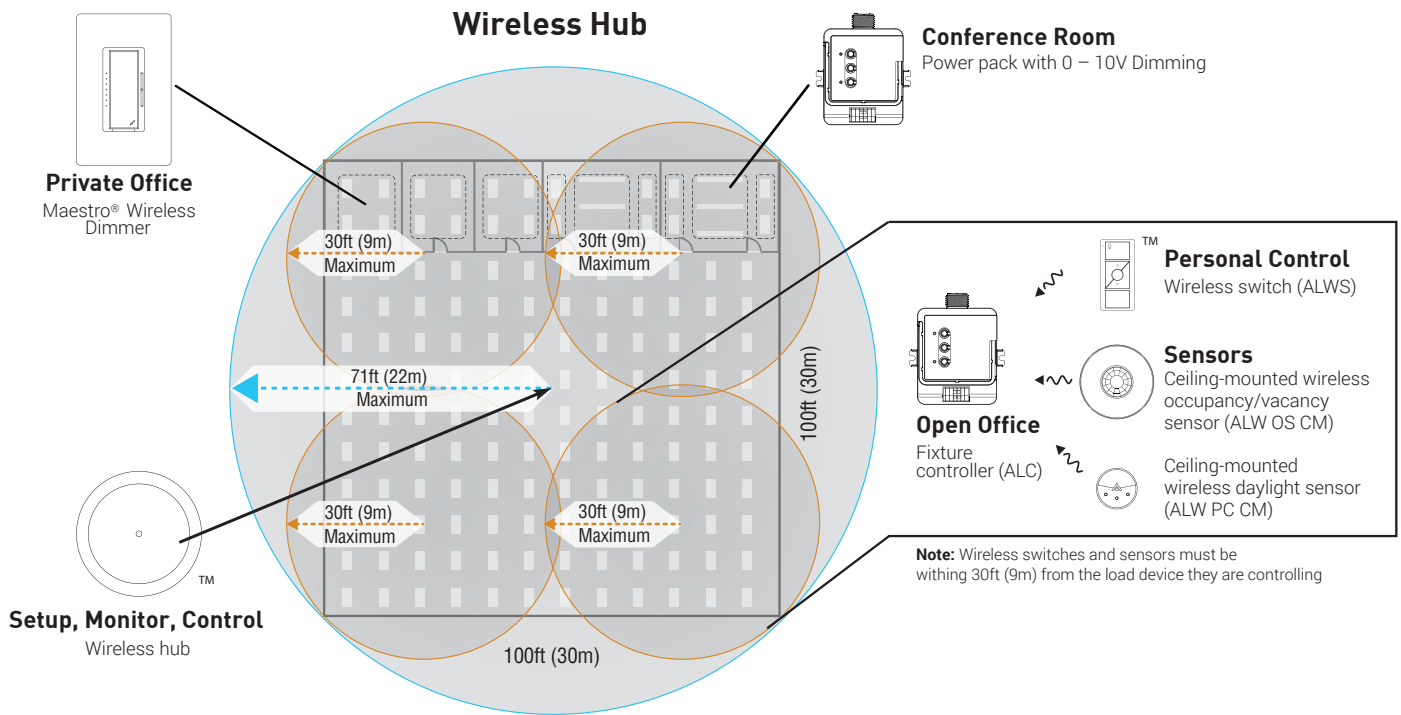

Range with Multiple Hubs

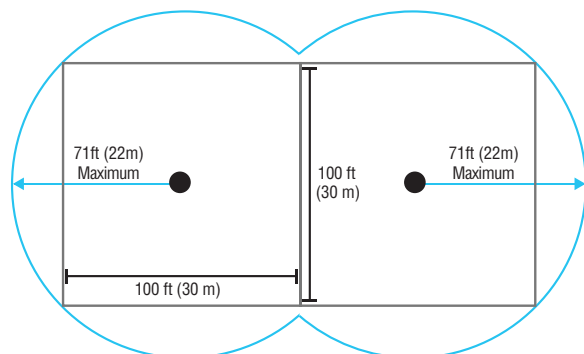

Wiring Diagram

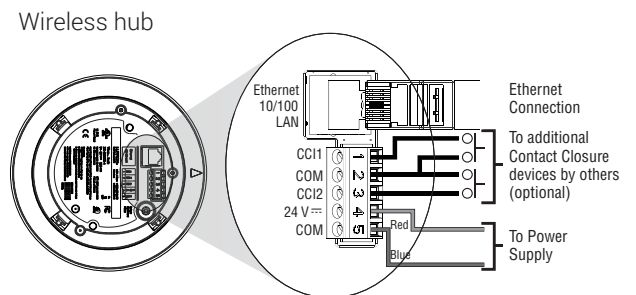



Wiring Diagram

Flush-Mount Adapter

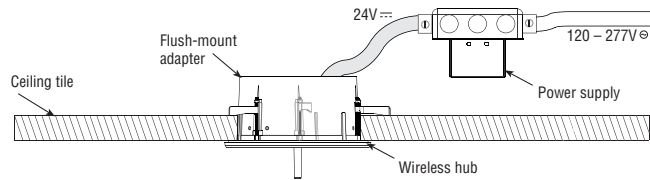

Surface-Mount Adapter

Note: Can be used for Chicago plenum space applications.

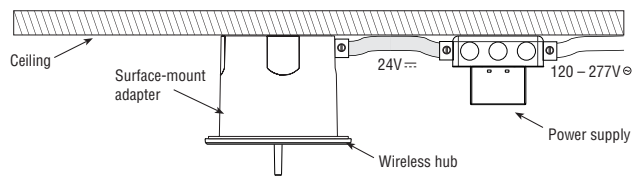

Inter-Hub Link Wiring

Note

- The inter-hub wiring is considered IEC PELV/NEC® Class 2; do not run in the same conduit as line (mains) voltage wiring.
- Wiring distance for any single link segment is 330ft (100m) max; use the provided or 3rd party Ethernet switches for longer distances (see specifications).
- Up to 64 hubs can be networked together.
- Hubs communicate over the inter-hub link using multicast UDP or TCP; a dedicated network is recommended but not required.
- The Wi-Fi access port cannot be used to create an ad hoc network for use as the inter-hub communication link.

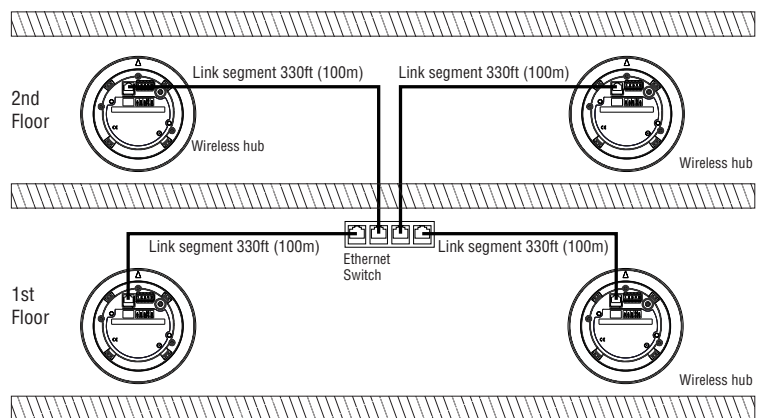

Ports Used

Traffic	Port	Type	Connection	Description
Outbound	443	TCP	Ethernet & Wi-Fi	Used to communicate with software update server
	5353	UDP	Ethernet	Used for Bonjour networking protocol
	47808 (configurable)	UDP	Ethernet	Used for BACnet integration into Building Management Systems
	8443	TCP	Ethernet & Wi-Fi	Used to communicate with webserver from wireless hub
	80	TCP	Ethernet & Wi-Fi	Used to start web connection
Inbound	443	TCP	Ethernet & Wi-Fi	Used to serve user interface to smart device
	47808 (configurable)	UDP	Ethernet	Used for BACnet integration into Building Management Systems
	8443	TCP	Ethernet & Wi-Fi	Used to communicate with webserver from wireless hub
	80	TCP	Ethernet & Wi-Fi	Used by other hubs to proxy



The AirLink System

Wireless controls & sensors



Wireless remotes & switches



Occupancy/Vacancy & Daylight sensors



AirLink-integrated Fixtures



AirLink-compatible Fixtures



Plug load controllers

Centralized control & integration

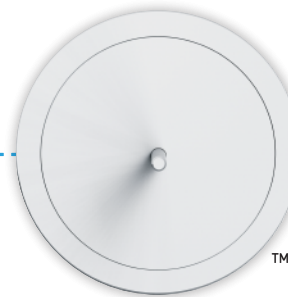

Wireless hub

Wired / Ethernet



Demand Response



BACnet integration

Simple-to-use software

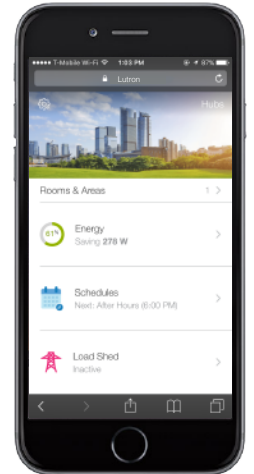

Lighting control web app

Contact LSI Controls



Sales
controls.sales@lsi-industries.com



Support
controls.support@lsi-industries.com
1 (800) 436-7800 (support, option 8)



More information
For more information on AirLink, visit our website at www.lsi-airlink.com/airlink