

# Zone Court Linear High Bay (ZCL) Series

## Installation and Assembly Instructions



### ⚠ WARNING

#### Risk of fire, electric shock, injury, or property damage

Risk of electric shock--Disconnect power to equipment before installing or servicing.  
This equipment must be installed according to all applicable codes & ordinances.  
Installation and service of this equipment must be performed by qualified service personnel.  
Do not install damaged equipment.  
Read these instructions before installing, servicing, or maintaining this equipment.  
Save these instructions for maintaining and servicing.

### ⚠ CAUTION

Failure to follow instructions or altering equipment could result in damage and void warranty.  
Edges may cut--wear gloves while handling or servicing this equipment.  
Inspect equipment for damage from shipping and handling.

## LUMINAIRE PREPARATION

1. Remove the luminaire from the carton and inspect luminaire for damage. Do not install a damaged luminaire.
2. Identify which model has been ordered and determine mounting method for appropriate mounting instructions on the following pages.

## WIRING INFORMATION

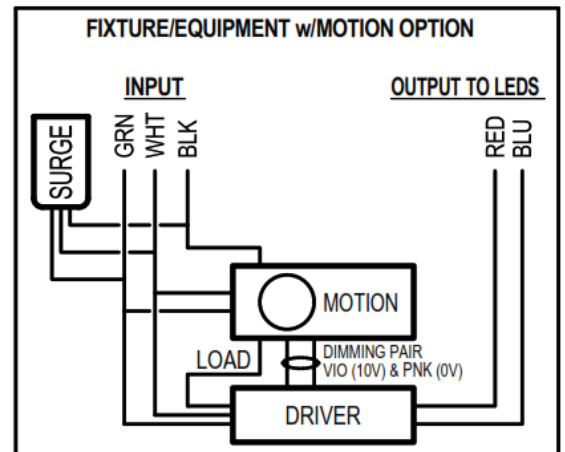
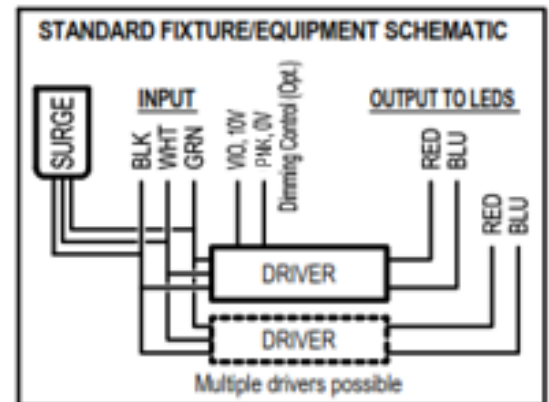
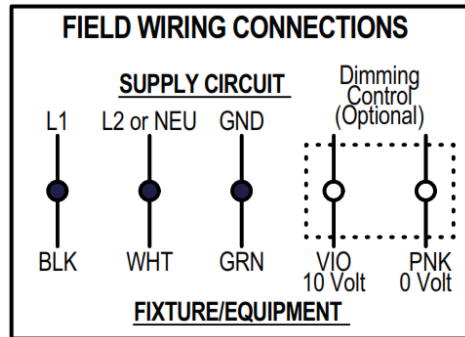

### Integral Bluetooth Motion and Photocell Sensor Option – IMSBTL

The sensor configuration app is available for both iOS and Android devices. Search the APP Store for LSI sensor configuration and download. It is used to set up a password, change default settings and testing. If no password is set within 7 days of the sensor being powered up it will need to be reset. For complete details download the LSI Sensor Config App User Guide <https://www.lsicorp.com>

# Zone Court Linear High Bay (ZCL) Series

## Installation and Assembly Instructions

### HANDLING INSTRUCTIONS

When removing the luminaire from the carton and during installation **DO NOT** use the LED heat sink modules for carrying. Use the end caps and center driver box channel. Improper handling of luminaire may damage fixture.

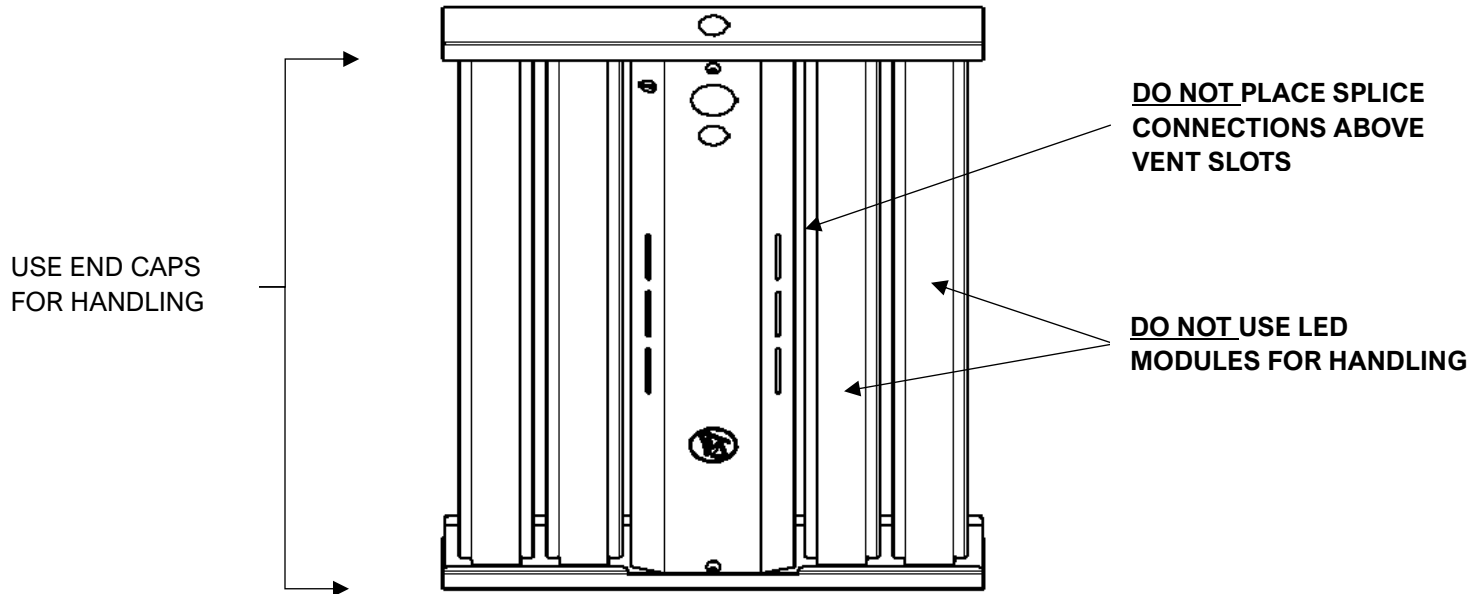

Inspect the luminaire and mounting locations for any damages. If the fixture is damaged, do not use. Ensure the mounting location is suitable for the luminaire and rated to support the weight of the fixture.

# Zone Court Linear High Bay (ZCL) Series

## Installation and Assembly Instructions

### MOUNTING

Make sure supply power is **OFF** prior to installation. Installing with live supply voltage can damage electronics and void fixture warranty.

#### Suspended Mounting

If mounting an EM fixture use the TCH mounting cable to properly adjust the fixture for horizontal Level.

#### TCH10 – Toggle Cable

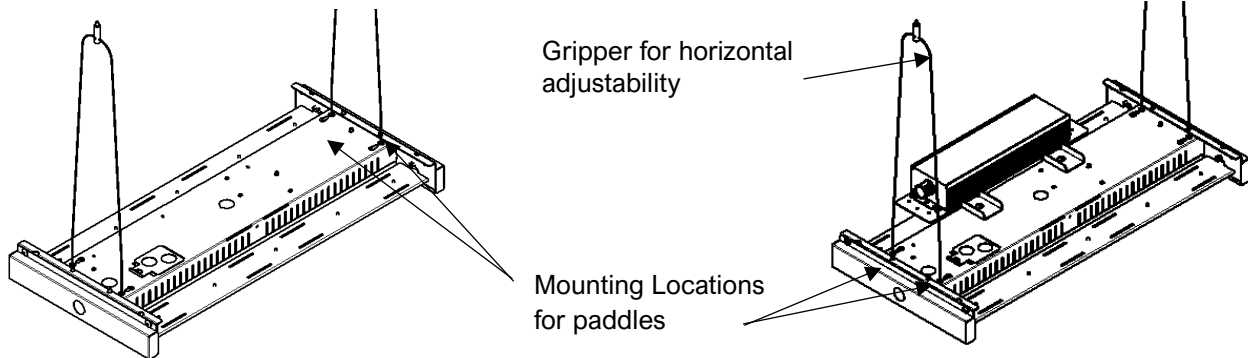

#### MCH10 – Hook Cable

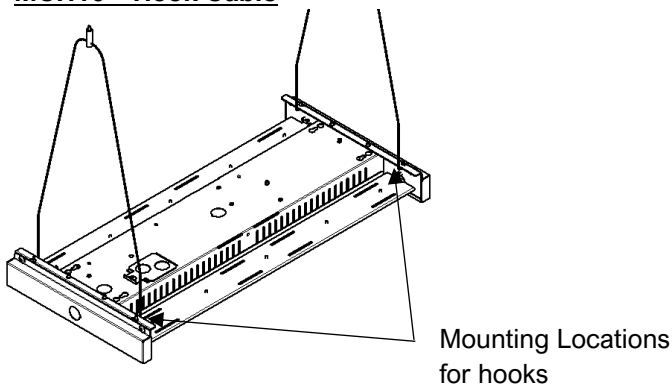

#### SHC – Single Hub Chain

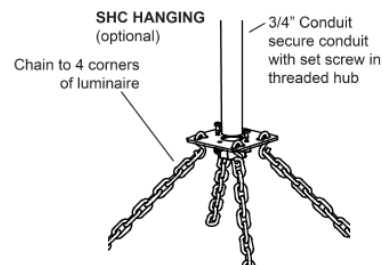

#### AHC – Single Hub Cable

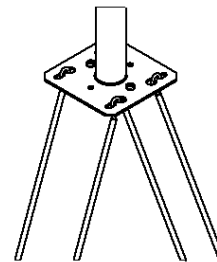

# Zone Court Linear High Bay (ZCL) Series

## Installation and Assembly Instructions

### Surface / Pendant Mounting

#### SMK – Surface Mount Kit

Attach the Surface mount box to mounting surface before securing to the fixture. Once the box has been secured to the mounting surface, use the (2) supplied #10 screws to mount the box to the fixture. Ensure the mounting legs of the box are properly seated into the mounting channel. Make any necessary electrical connections at this time. All connections and wire must meet applicable electrical codes. Attach Surface box side covers with supplied screws.

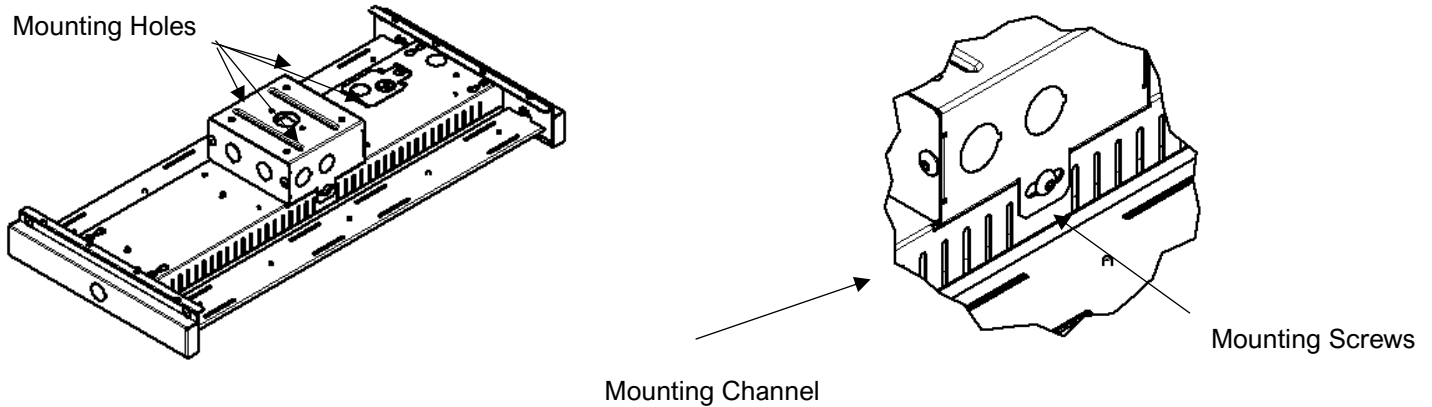

#### PMK – Pendant Mount Kit

Attach the Pendant mounting hub to the inside of the Pendant box using the (2) supplied #8 screws. Attach the Pendant mount box to the fixture using the (2) supplied #10 screws. Ensure the mounting legs of the box are properly seated into the mounting channel. Make any necessary electrical connections at this time. All connections and wire must meet applicable electrical codes. Attach Pendant box side covers with supplied screws.

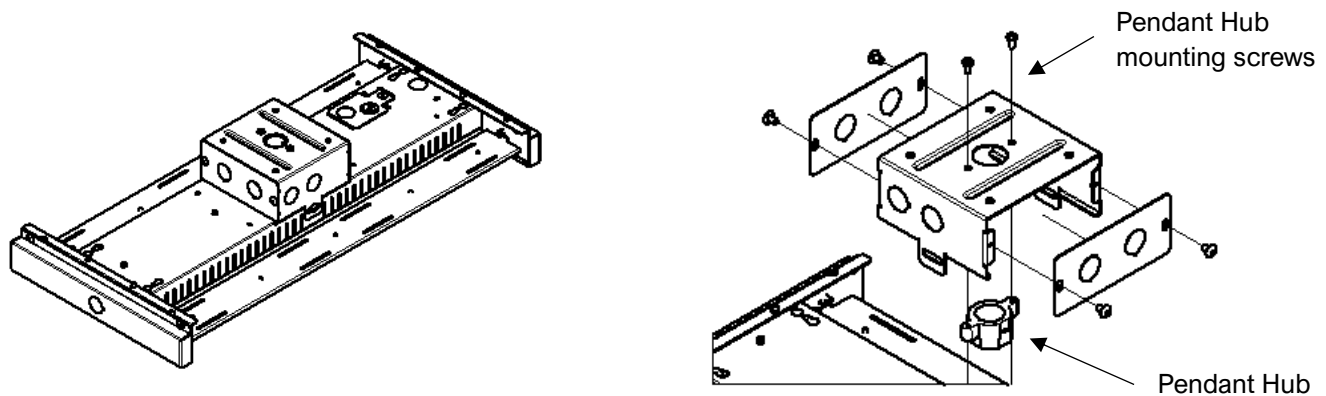

# Zone Court Linear High Bay (ZCL) Series

## Installation and Assembly Instructions

### SENSORS

---

#### OMS – External Motion Sensor

The OMS External mounted motion sensor will be pre-wired to the fixture but not attached to the end plate. Upon handling the fixture, snap the OMS into the end plate for proper installation. Ensure the sensor head and sensor lens are parallel to the floor.

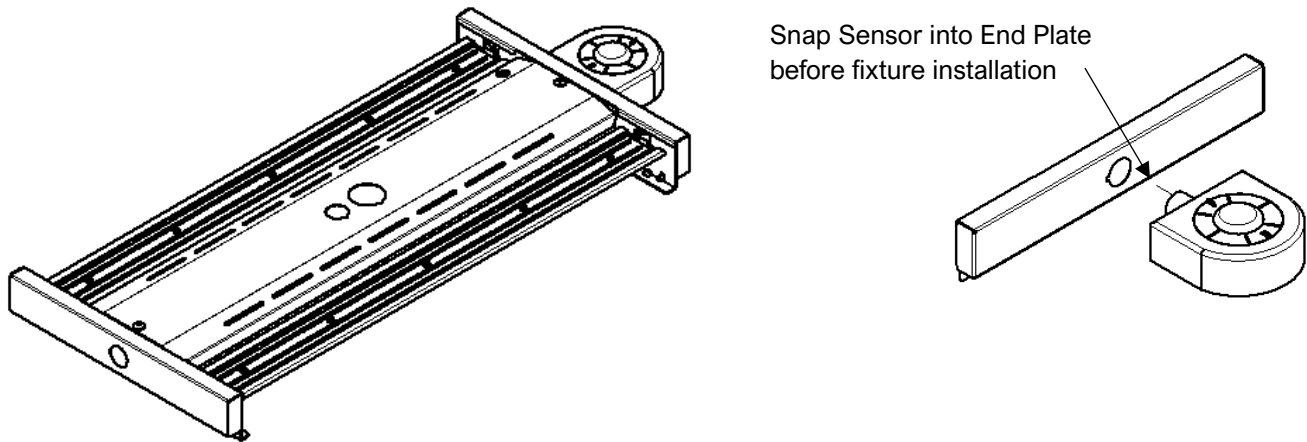

---

#### IMSBTxL / ALSCxx– Integral Motion Sensor

The IMSBTxL and ALSCxx motion sensor will be pre-installed to the driver cover and pre-wired to the fixture.

Motion Sensor lens will vary depending on mounting height

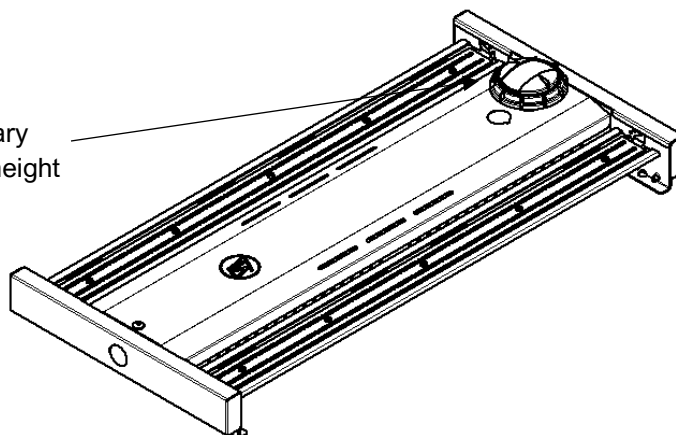

# Zone Court Linear High Bay (ZCL) Series

## Installation and Assembly Instructions

### ROTATBLE OPTIC CONFIGURATION

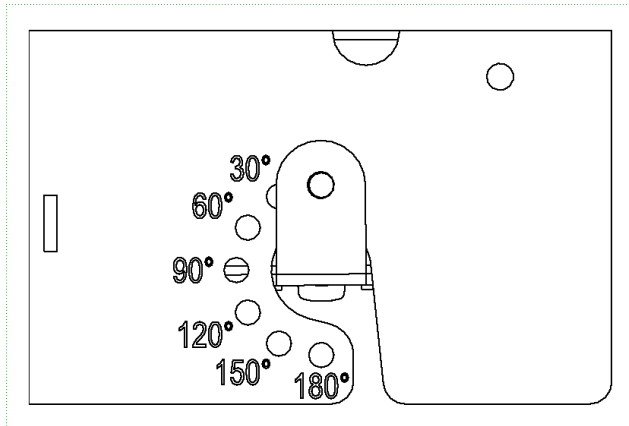

**DIRECT (0°)**

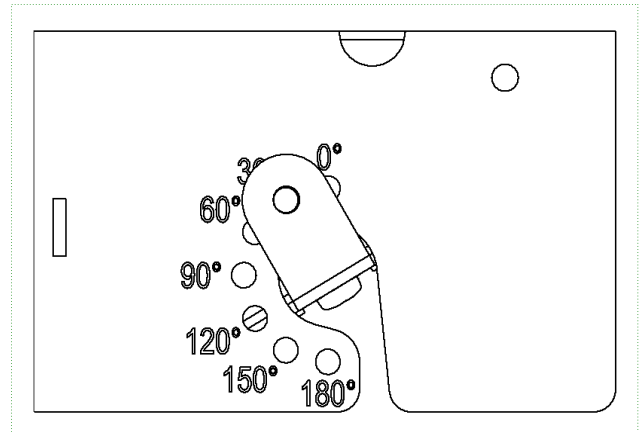

**30°**

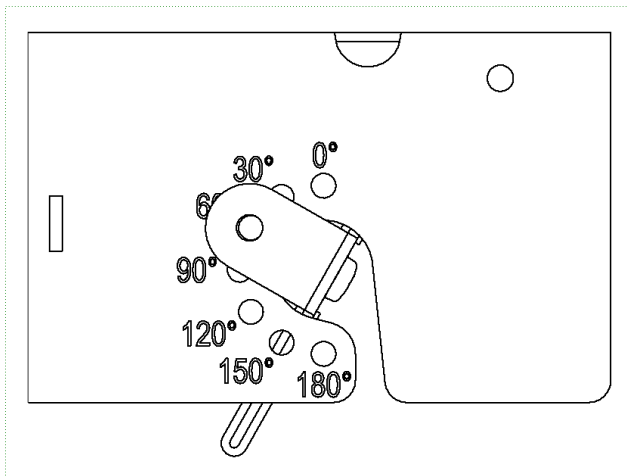

**60°**

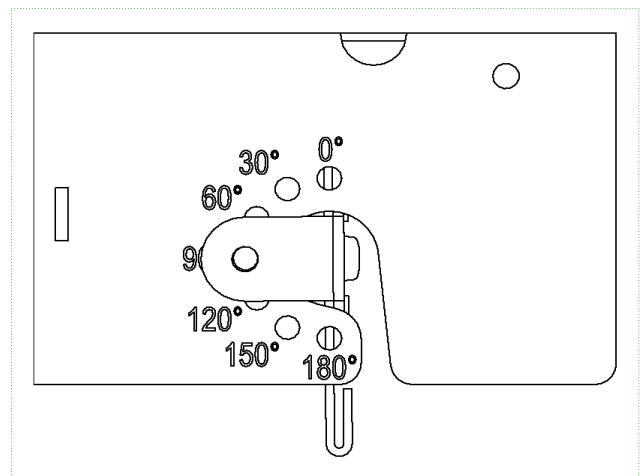

**90°**

<b><u>Optical Preset</u></b>	<b><u>Angle</u></b>
D	0° - Downlight
3	30° - Wide
6	60° - Extra Wide
9	90° - Side Light
I	180° - Indirect (100% Uplight)

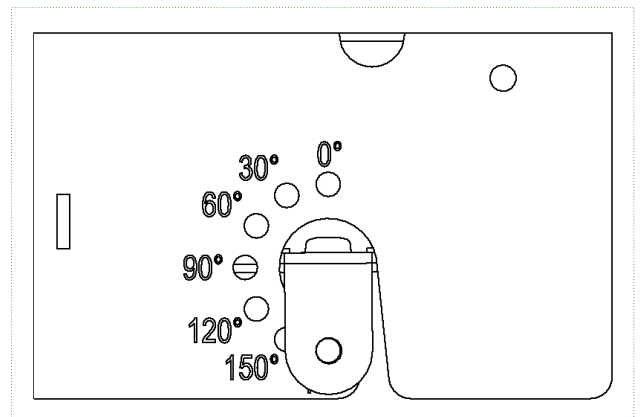

**INDIRECT (180°)**

# Zone Court Linear High Bay (ZCL) Series

## Installation and Assembly Instructions

### LENS / OPTIC

---

The lenses snap into the hem on the heatsink. To remove, squeeze lens while applying outward pressure to disengage the lens leg from the hem. Continue to repeat the process along the length of the lens to fully disengage. To install the lens, place one side of the lens leg into the hem, then squeeze together to engage the other leg into the opposite hem. Continue to repeat this process along the length of the lens until fully engaged.

The narrow optic snaps into the cutouts on the heatsink. There will be an audible “click” once the lens is snapped into place. Ensure that the optic mounting legs are fully snapped in place to achieve optimal optical performance. Removal of the narrow optic is similar to the lens removal.

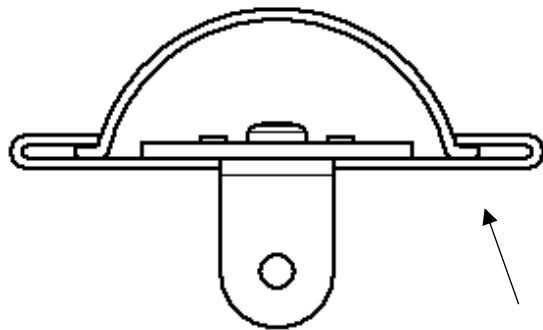

**CAC / CAD**

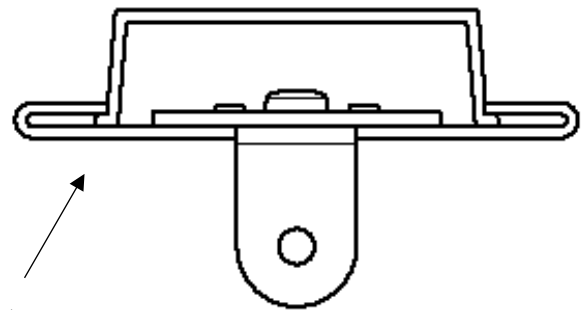

**FAC / FAD / FPC / FPD**

Lens snaps into heatsink hems

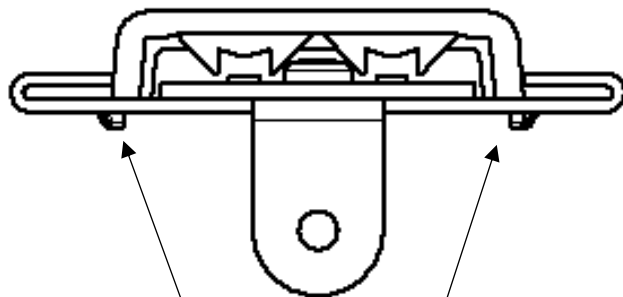

Optic snaps into heatsink cutouts

**NAC**

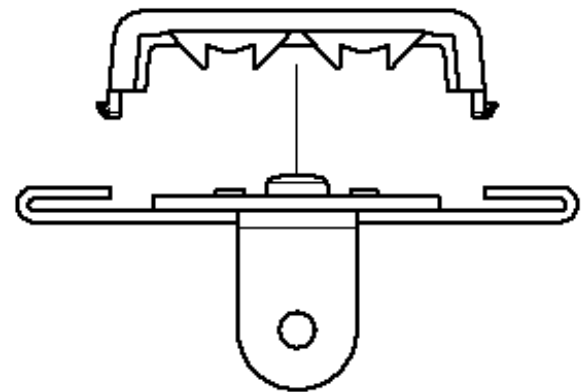

\*4ft fixtures require multiple optics along the length. These optics overlap.

# Zone Court Linear High Bay (ZCL) Series

## Installation and Assembly Instructions

### ZCL IDENTIFICATION

---

#### 2 FT

12,000lm / 15,000lm / 18,000 lm

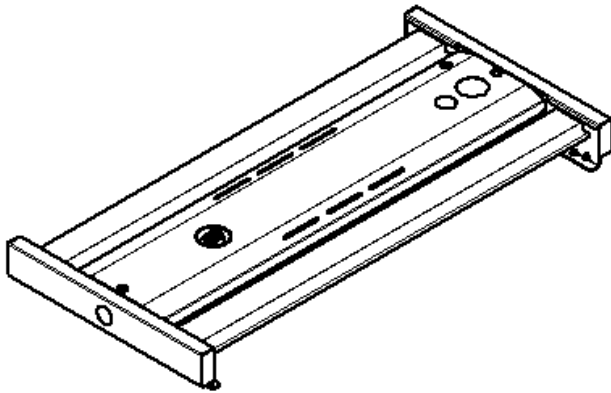

24,000lm / 30,000lm / 36,000 lm

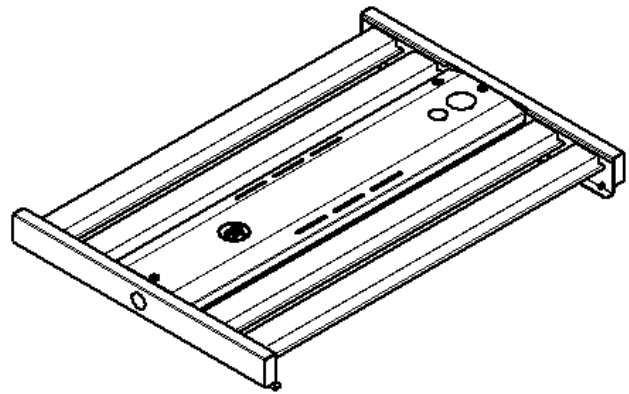

#### 4 FT

48,000lm / 60,000lm

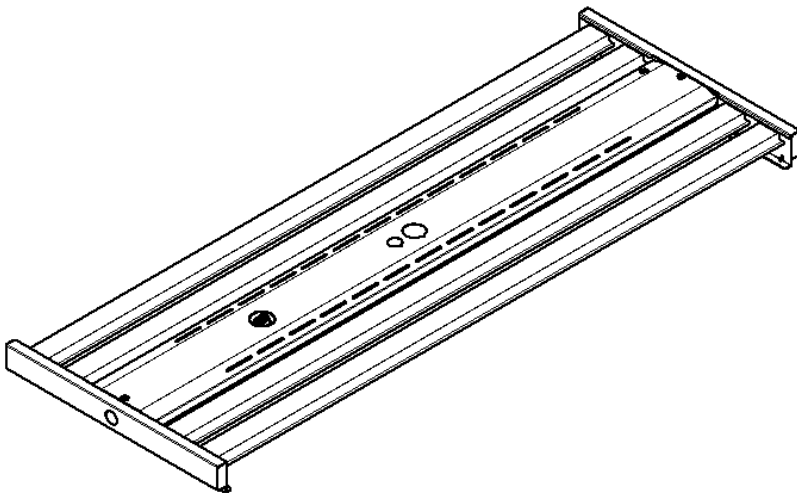



# Zone Court Linear High Bay (ZCL) Series

## Installation and Assembly Instructions

### ZCL-LG (LOW GLARE) IDENTIFICATION

---

#### 2 FT

12,000lm

15,000lm / 18,000lm / 24,000lm / 27,000lm

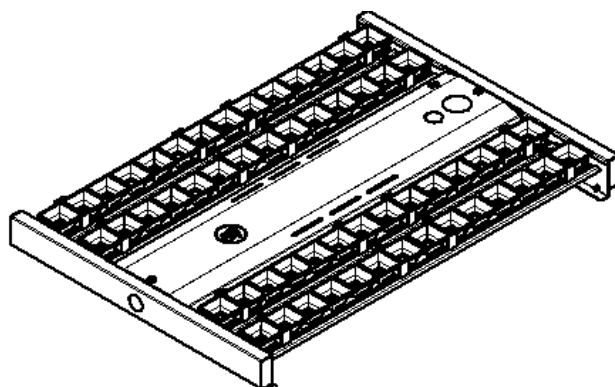
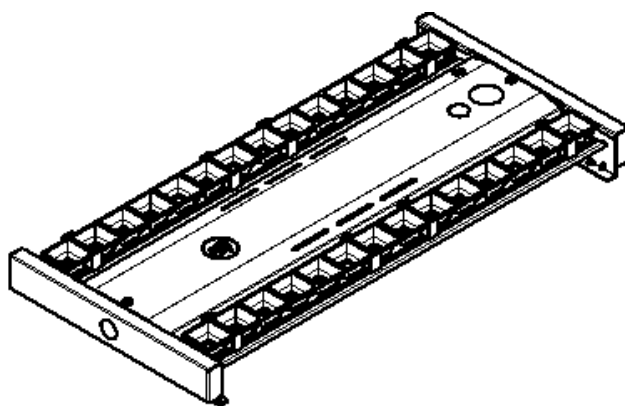

#### 4 FT

36,000lm / 48,000lm / 54,000lm

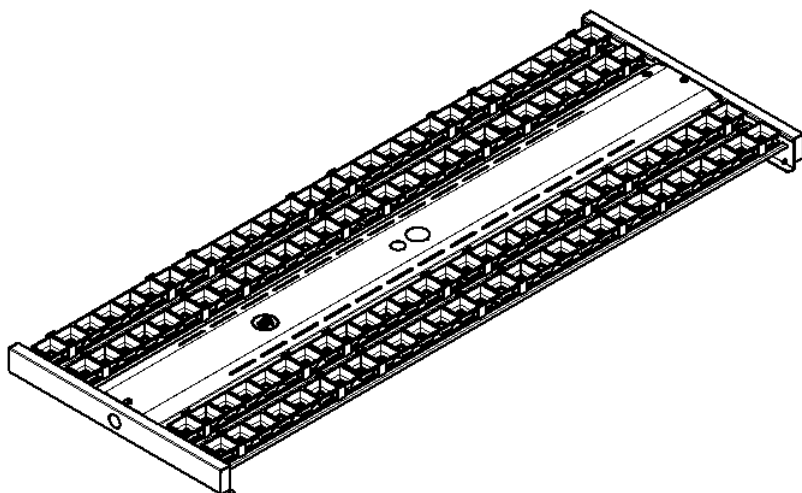

# Zone Court Linear High Bay (ZCL) Series

## Installation and Assembly Instructions

EM

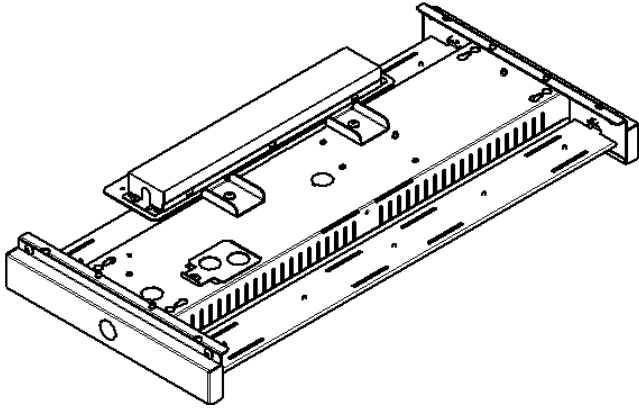

EMHV

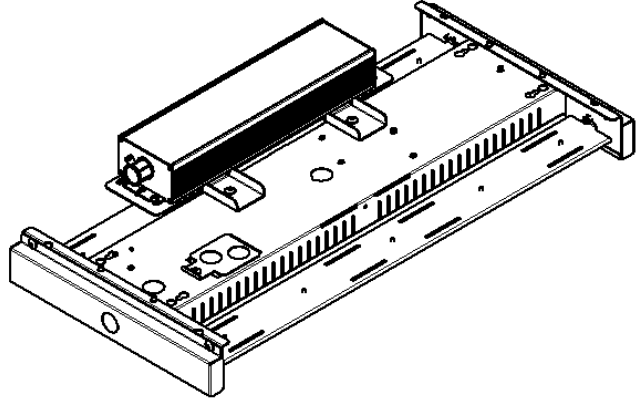

### Accessories

SHC

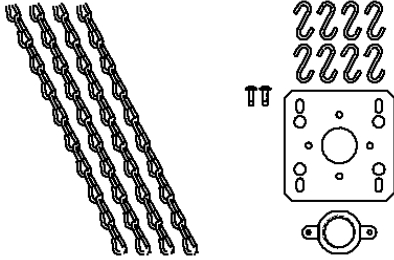

TCH10

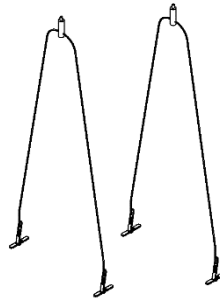

MCH10

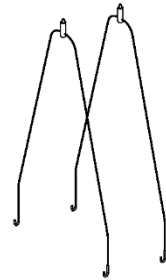

PMK

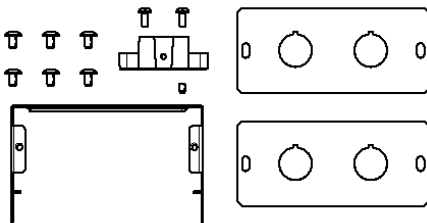

SMK

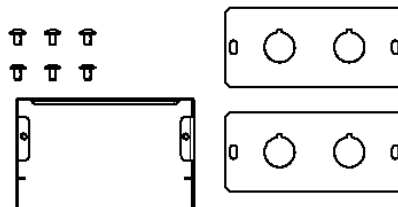

ACH

