

Value-Series Exit Sign (VE)

Installation Instructions

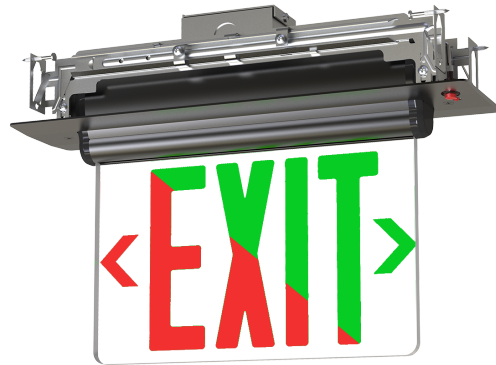

IMPORTANT SAFEGUARDS READ AND FOLLOW ALL SAFETY INSTRUCTIONS.

When using electrical equipment, basic safety precautions should always be followed including the following:

- **DISCONNECT AC POWER SUPPLY BEFORE SERVICING.**
- Installation and servicing of this equipment should be performed by qualified service personnel only.
- Ensure that the electrical wiring conforms to the National Electrical Code NEC® and local regulations if applicable.
- For use with metal enclosure wiring systems.
- Do not mount near gas or electrical heaters.
- Do not use outdoors.
- Equipment should be mounted in locations and at heights where it will not be readily subjected to tampering by unauthorized personnel.
- The use of accessory equipment not recommended by the manufacturer may cause an unsafe condition.
- Any modification or use of non-original components will void the warranty and product liability.
- Do not use this equipment for other than intended use.
- Use caution when servicing batteries. Battery acid can cause burns to skin and eyes. If acid is spilled on skin or eyes, flush acid with fresh water and contact a physician immediately.
- Allow battery to charge for 24 hours before first use.

SAVE THESE INSTRUCTIONS!

Visit us online at www.lsicorp.com

Value-Series Exit Sign (VE)

Installation Instructions

Recessed / Wall Recessed Mounting

1. Open front cover by blade screw driver, attach battery connector on PCBA (With Battery units only), disassemble J-box cover, punch out wire hole. Secure J-box on the top of fixture using (2) TM4*8 screws (supplied). Feed the AC wires out of J-box cover. Reattach J-box cover and front cover. (Fig. 1)
2. Unscrew and remove one end cap (test switch side). Disconnect test switch and LED indicator connector, remove test switch and LED indicator and LED bushing and set aside for next step. Reattach end cap on housing using (3) PB3*12 screws (supplied). (Fig. 2)
3. Snap LED bushing on the trim plate, assemble test switch and LED indicator on the trim plate. (Fig. 3)
4. Cut a 14-5/8" x 3-1/4" opening in the ceiling or wall, ensure the opening dimensions are less than the trimplate dimensions of 15-3/4"x 4".
5. Position recessed kits and hanger bars between joists. Make sure bar hangers are hanged in the right position. Position recessed kits temporarily by hammering "nail-in" tabs on bar hangers, then secure permanently with nails. Bar hangers should be level with bottom of joists. For T-bar installation, hang the ends of the hanger bars over the vertical part of the T-bar. (Fig. 4)
6. Adjust height of recessed kits vertically using adjusting slots and then tightening all screws on adjusting slots and bar hanger bracket to secure adjusting bracket and bar hangers.

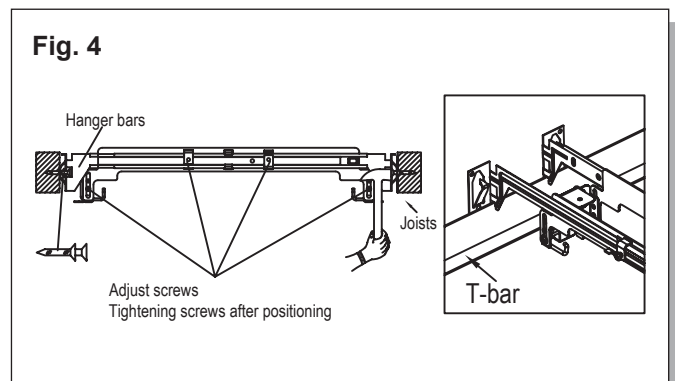
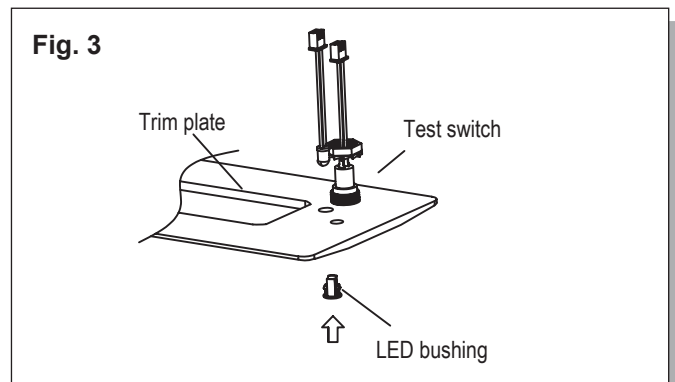
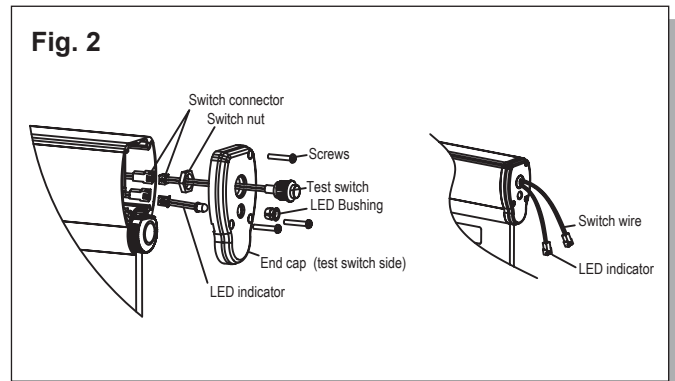
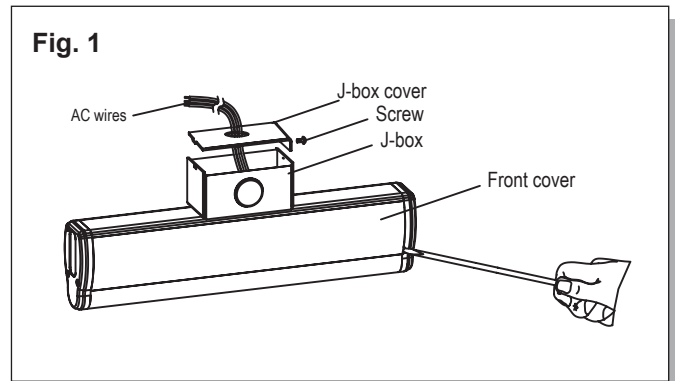

Red and Green Color Changeable

- This product default setting is red color.
- Slide the knob of slider switch to another side, then change to green color.

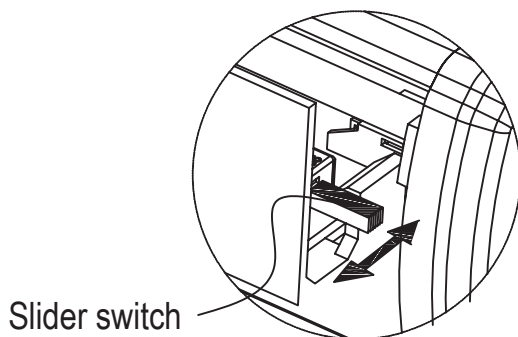

Value-Series Exit Sign (VE)

Installation Instructions

Recessed / Wall Recessed Mounting (continued)

7. Connect AC supply wiring; white wire for neutral, black wire for 120VAC input, orange wire for 277VAC input, green wire for grounding (see **Electrical Connections**). After wiring, insert wire nuts inside of J-box. (Fig. 5)
8. Insert EXIT panel into main body assembly gently. If EXIT panel is for single face, make sure EXIT letter direction is correct. (Fig. 6)
9. Insert fixture into hanger bar assembly and snap by spring. Connect test switch and LED indicator, notice the wires color should be match. Fix trim plate on the metal box using provided screws. (Fig. 7)

Determine Direction

- If chevron is needed, remove instruction film only.
- If chevron is not needed, remove chevron and instruction film.



Fig. 5

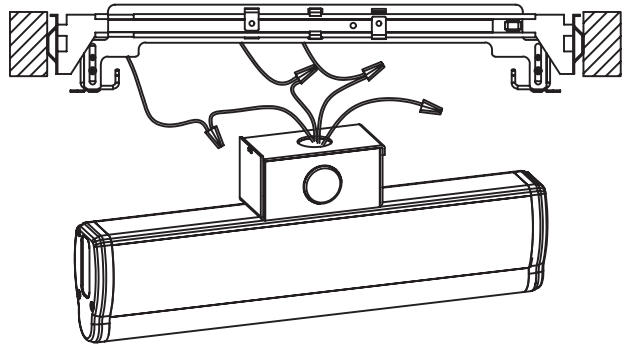

Fig. 6

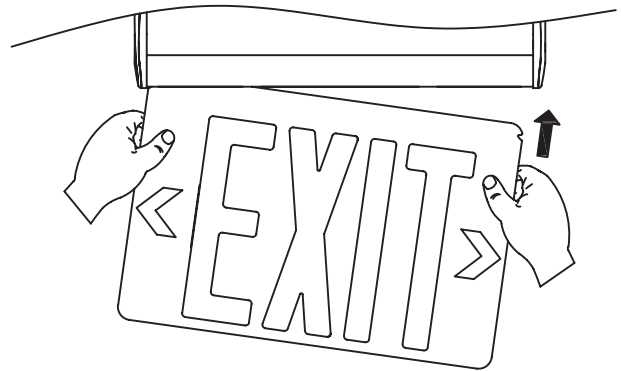
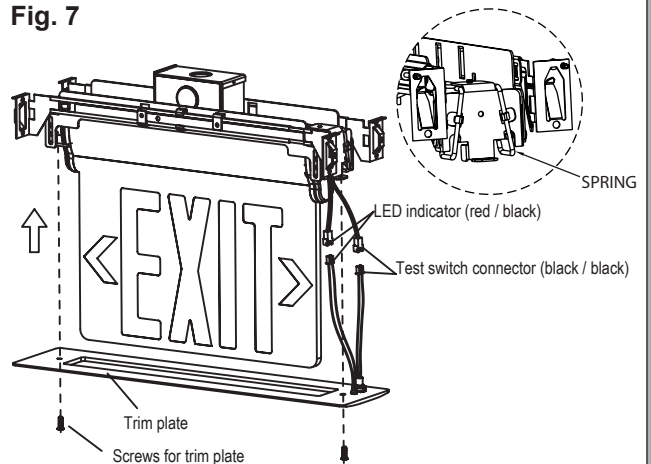

Fig. 7



Value-Series Exit Sign (VE)

Installation Instructions

Recessed / Wall Recessed Mounting (continued)

10. For wall recessed, ceiling mounting rotated 90° becomes recessed wall mounting.
11. Peel off protective film from acrylic panel.. (Fig. 8)
12. Determine direction for chevron indicator.
Note: Alcohol or other irritant detergent should not be used to clean the acrylic panel.

Surface Ceiling & Wall Mounting

1. Attach crossbar to junction box using #8-32*1" screws (supplied by others) .
2. Use screwdriver to open front cover to connect battery connector (With Battery units only). (Fig. 9)
3. Feed AC supply wires through canopy center hole.
4. Assemble canopy onto main body assembly with (2) PM4*12 screws(supplied) and make proper wire connections. (See **Electrical Connections**).
5. Use (2) PM4-40 screws (supplied) tighten canopy to crossbar. (Fig. 10)

Fig. 8

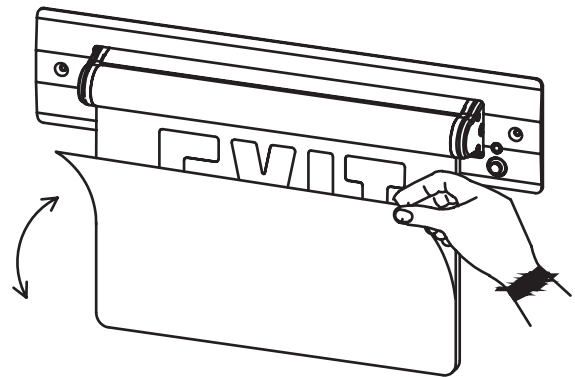
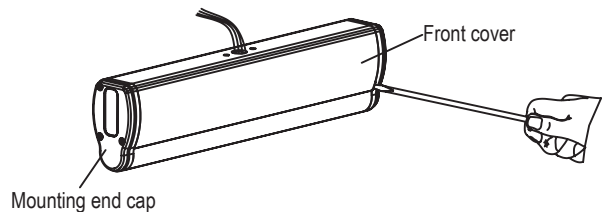

Fig. 9



Electrical Connections

- Make the proper supply wire connections.
- If using 120VAC, connect the black and white wires to the building utility.
- If using 277VAC, connect the orange and white wires to the building utility.
- Cap off unused wires. In all cases, use standard wire nuts in connection to wires.

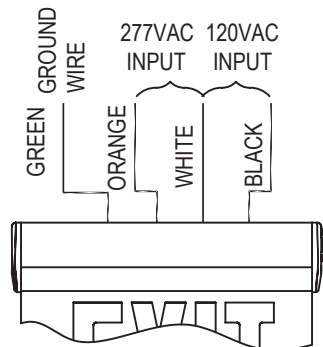
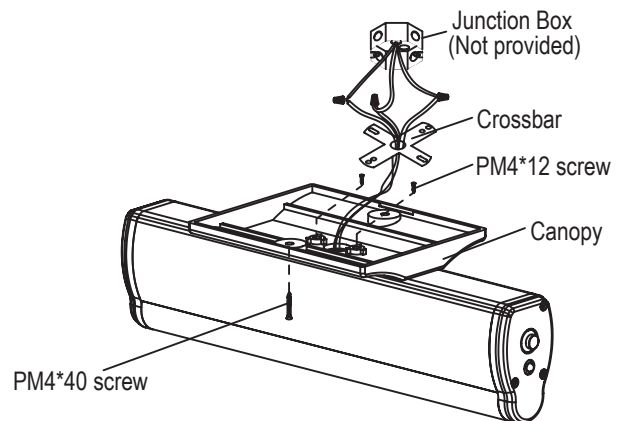

Fig. 10



Value-Series Exit Sign (VE)

Installation Instructions

Surface Ceiling & Wall Mounting (continued)

6. Insert EXIT panel into main body assembly gently. If EXIT panel is for single face, make sure EXIT letter direction is correct.
7. Peel off protective film from acrylic panel. (Fig. 11)
8. Determine direction for chevron placement.
9. The unit can be installed on any surface. You may rotate the EXIT panel in any angle from 0° to 180°, Ceiling mounting rotate 90° becomes a wall mount configuration. (Fig. 12)

Surface End Mounting

1. Attach crossbar to junction box.
2. Use screwdriver open front cover to connect battery connector.
3. Remove the hole plug from mounting end cap.
4. Pull out all AC supply wires and feed wires through the center holes of mounting end cap and then canopy. (Fig. 13)
5. Reference steps 4 - 8 in **Surface Ceiling & Wall Mounting** above for surface end mounting.

Fig. 11

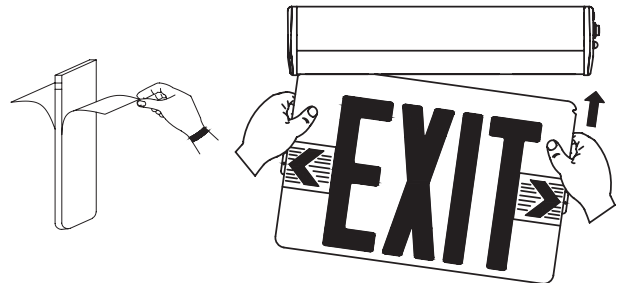

Fig. 12

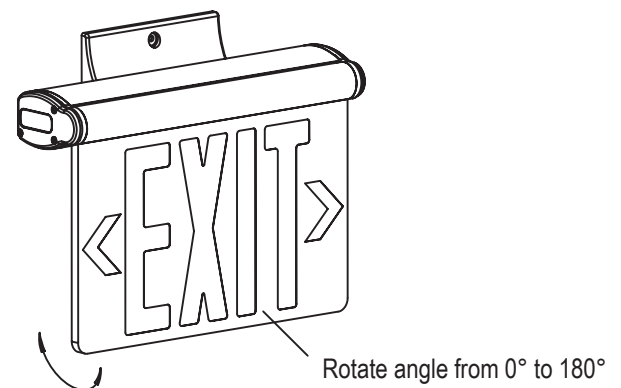
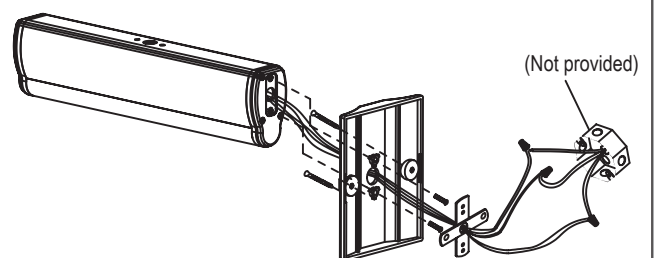

Fig. 13



Value-Series Exit Sign (VE)

Installation Instructions

Testing and Reporting Instructions (SD2 models)

1. When AC power is supplied to fixture, the unit will automatically initiate a self-test and self-diagnostic test as follows:

- Verifies battery disconnection, charger board failure at every 5 seconds.
- 1 minute self-testing every month.
- 30 minutes self-testing on every 6 months after installation.
- 90 minutes self-testing on every 12 months after installation.

2. Dual color LED lamp indicator shows the following status:

- Green color: On / Ready
 Blinking: Testing
- Red color: (Service Alert)
- Service Alert LED Code (Red color LED lamp indicator)

●	One blink,	4 second pause	Battery is not connected
● ●	Two blinks,	4 second pause	Battery voltage too low
● ● ●	Three blinks,	4 second pause	Charger board circuit failure
● ● ● ●	Four blinks,	4 second pause	Transfer function failure
● ● ● ● ● ● ●	Seven blinks,	4 second pause	LED strip failure

Note: After solving the fault of emergency equipment, please press test button for 2 seconds then release to reset. LED indicator will show green.

3. SD2 models also have a manual test function, press test button as follows:

Press test button once	30 seconds discharge test
Press test button twice within 2 seconds	3 minutes discharge test
Press test button 3 times within 2 seconds	30 minutes discharge test
Press test button 4 times within 2 seconds	90 minutes discharge test