

# Installation and Assembly Instructions SFR Soffit Fixture Recessed

## ⚠ WARNING

### Risk of fire, electric shock, injury or property damage

Risk of electric shock--Disconnect power to equipment before installing or servicing.  
This equipment must be installed according to all applicable codes & ordinances.  
Installation and service of this equipment must be performed by qualified service personnel.  
Do not install damaged equipment.  
Read these instructions before installing, servicing or maintaining this equipment.  
Save these instructions for maintaining and servicing.

## ⚠ CAUTION

Failure to follow instructions or altering equipment could result in damage and void warranty.  
Edges may cut--wear gloves while handling or servicing this equipment.  
Inspect equipment for damage from shipping and handling.

### LUMINAIRE PREPARATION

1. Remove the luminaire from the carton and inspect luminaire for damage. Do not install a damaged luminaire.
2. **Important:** 6" of soffit clearance is required for luminaire installation.

### WIRING INFORMATION

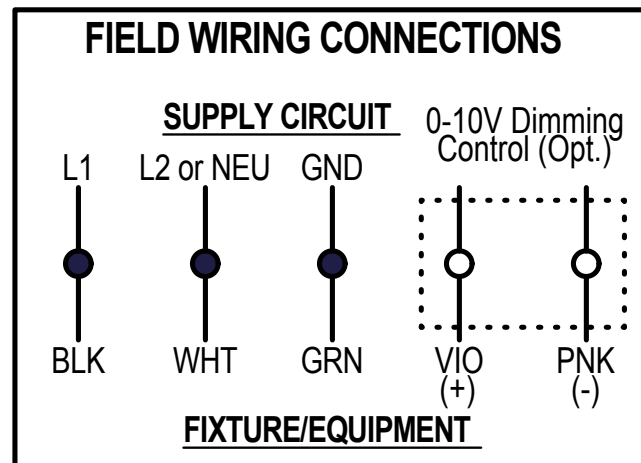

### Tools Required

- 4-1/2" Hole Saw & Drill
- Wire Strippers/Cutters
- 5/16" Nut Driver

Installation Questions  
Call LSI Field Service Dept.  
800-436-7800 Fax 877-861-1368

# Installation and Assembly Instructions SFR Soffit Fixture Recessed

### Step 1

1. Cut a 4.5" (4-1/2") diameter access hole in mounting surface using a hole saw. Make sure hole edge is free of burrs. Pull conduit/wiring through hole to below surface.

### Step 2 (Fig. 1)

2. Remove (4) 8-32 screws from Junction Box Cover and save.
3. Remove (1) knockout plug per conduit fitting used.
4. Connect luminaire wires to appropriate supply leads using properly sized connectors (supplied by others). Refer to wiring information to make connections.
5. Replace Junction Box Cover using screws removed in step 1. Torque screws to 20±5 in-lb.

### Step 3 (Fig. 2)

6. Raise arms on both mounting clips to their fully raised position.

### Step 4 (Fig. 3)

7. Feed luminaire assembly through hole, making sure mounting clip arms are still raised. Release clip arms once they are through hole. Make sure mounting flange and gasket are firmly seated against mounting surface.

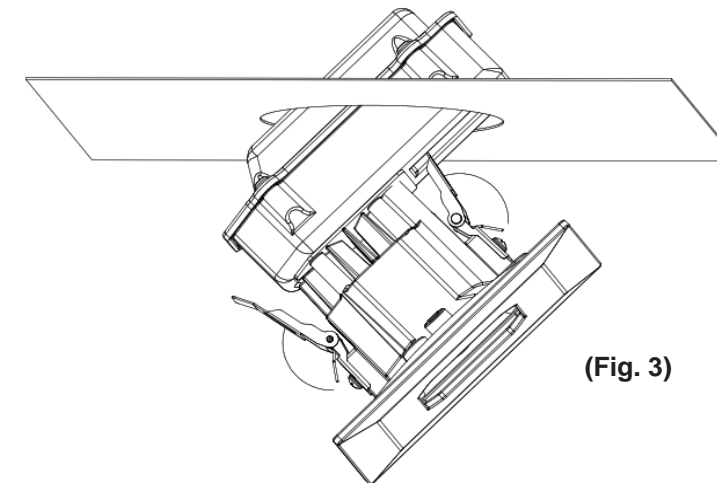

(Fig. 3)

### Step 5 - Optional (Fig 4)

8. If top of mounting surface is accessible, install (2) Locking Collars, using (2) 10-24 screws provided.
9. Torque screws to 30±5 in-lb.

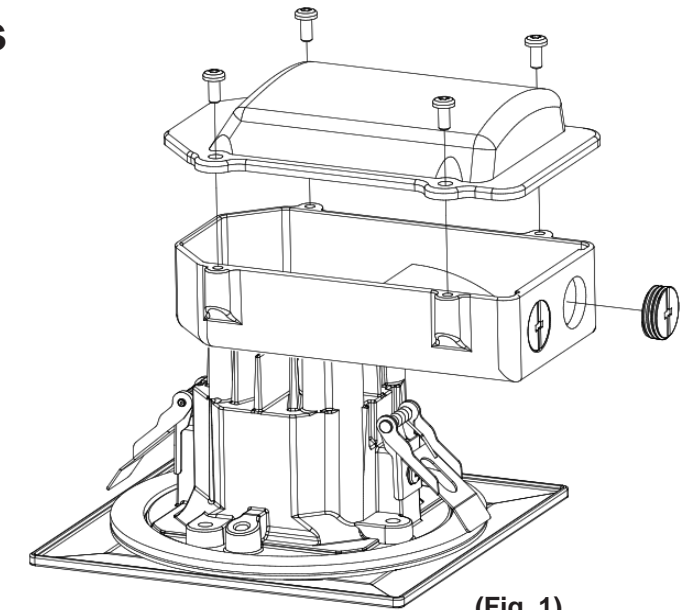

(Fig. 1)

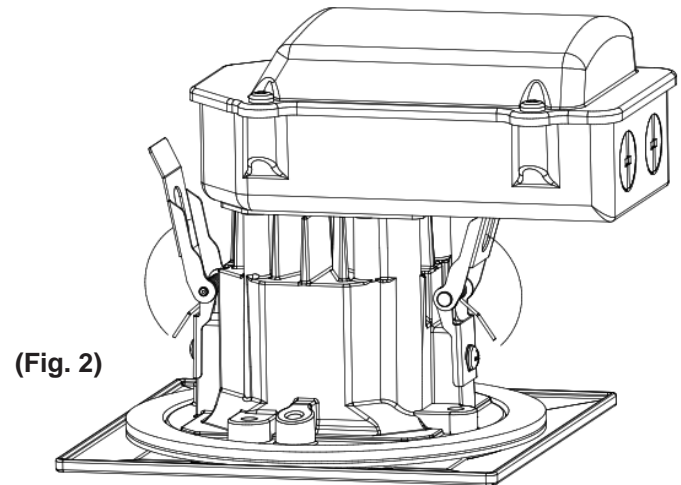

(Fig. 2)

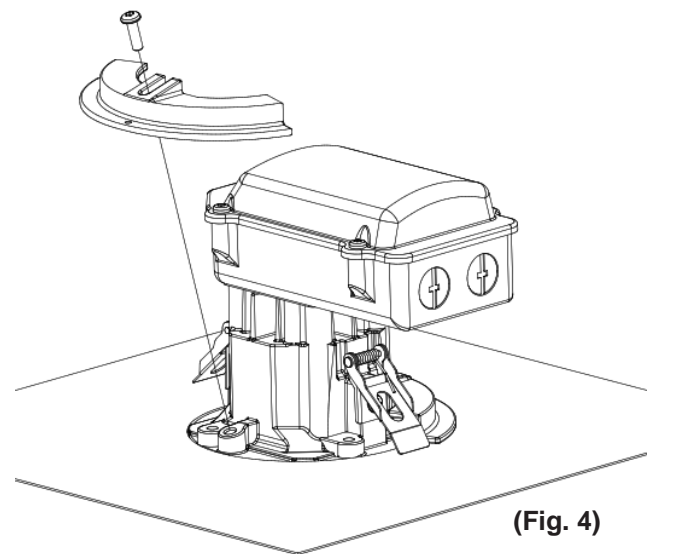

(Fig. 4)

Installation Questions  
Call LSI Field Service Dept.  
800-436-7800 Fax 877-861-1368