

# Installation and Assembly Instructions Zone Large Area Light (ZNL) Series



## ⚠️ WARNING

### Risk of fire, electric shock, injury or property damage

Risk of electric shock--Disconnect power to equipment before installing or servicing.  
This equipment must be installed according to all applicable codes & ordinances.  
Installation and service of this equipment must be performed by qualified service personnel.  
Do not install damaged equipment.  
Read these instructions before installing, servicing or maintaining this equipment.  
Save these instructions for maintaining and servicing.

## ⚠️ CAUTION

Failure to follow instructions or altering equipment could result in damage and void warranty.  
Edges may cut--wear gloves while handling or servicing this equipment.  
Inspect equipment for damage from shipping and handling.

### LUMINAIRE INSPECTION

1. Remove the luminaire from the carton and inspect luminaire for damage. Do not install a damaged luminaire.

### WIRING INFORMATION

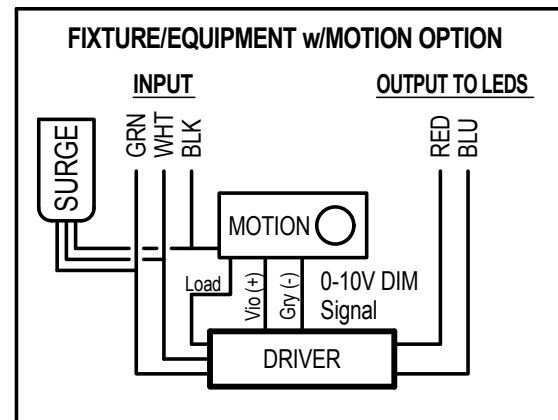
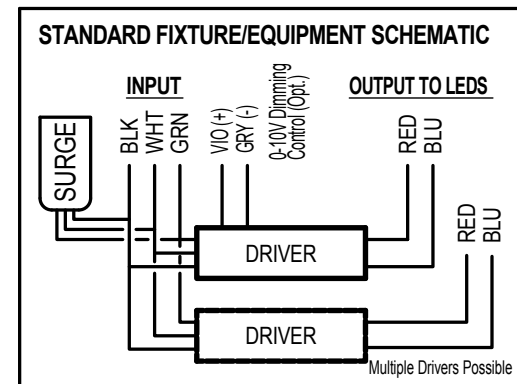
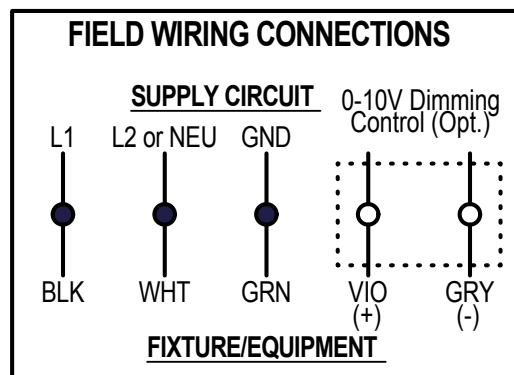

**Integral Bluetooth Motion and Photocell Sensor Option – IMSBT**  
The sensor configuration app is available for both iOS and Android devices. Search the APP Store for LSI sensor configuration and download. It is used to set up a password, change default settings and testing. If no password is set within 7 days of the sensor being powered up it will need to be reset. For complete details download the LSI Sensor Config App User Guide <https://www.lsi-industries.com>

# Installation and Assembly Instructions Zone Large Area Light (ZNL) Series

## Luminaire Preparation and Mounting to Pole

1. Verify the luminaire optic type CT and rotation (None, Left, Right) agree with site lighting plan for the specific pole location.
2. Open fixture driver compartment by loosening door fastener (not required for FMS option). Mounting hardware is located in luminaire (for FMS option remove (2) Nuts from factory installed studs and use on interior of pole for mounting as shown).
3. Fasten luminaire to pole per the figure below. Tighten fasteners to 25 ft. lbs.
4. Route wires through center hole and grommet into driver compartment and make wiring connections.

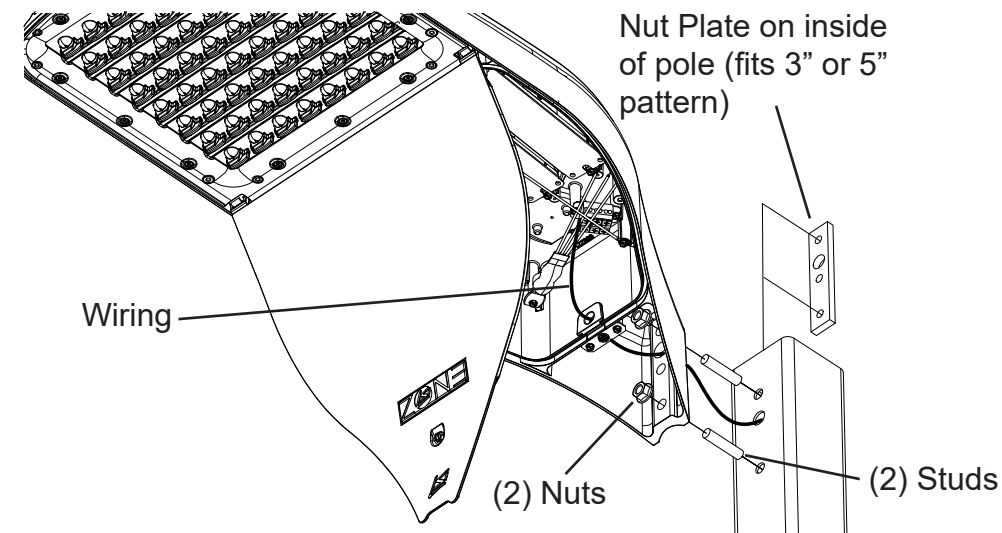

## IL & IH Light Shield Attachment

1. Locate (4) drill spots on lens frame and drill (4) 11/64" diameter holes through lens frame (1/2" deep) to receive self-threading 10-24 fasteners.
2. Align IL or IH Light Shield notches to Lens Frame arrows and place the Shield on the Lens Frame.
3. Attach IL or IH Light Shield to Lens Frame with (4) fasteners provided.

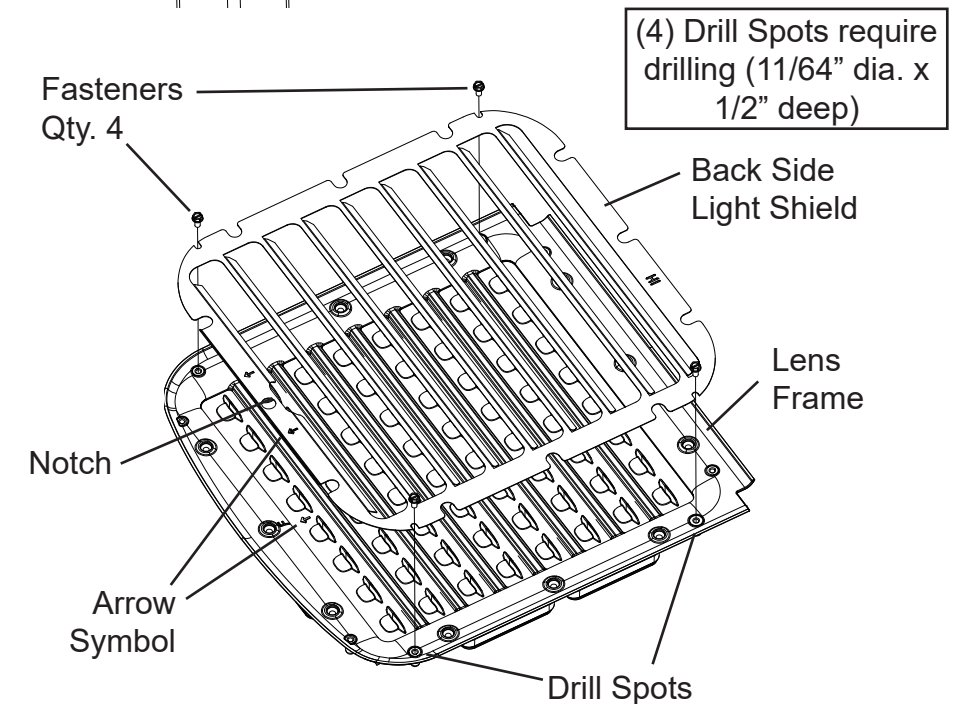

Installation Questions  
Call LSI Field Service Dept.  
800-436-7800 ext. 3300