

HLN Hilton Series Integral Louver House Side Shield Installation and Assembly Instructions

FOR XCN4 SERIES, SEE OPPOSITE SIDE!

WARNING - Risk of fire or electrical shock! Disconnect power before installing shield!

WARNING - Before proceeding, read all instructions carefully to ensure proper and safe installation!

1. Louver can only be mounted one way (follow illustration below for proper mounting orientation).
2. Kit contains one Integral Louver Shield and (4) self-threading Torx head screws.
3. Align screw clearance holes in shield with the predrilled holes in the lens frame casting.
4. Using a Torx screwdriver, tighten screws to 20 IN-LBS.
5. Installation of shield is now complete.

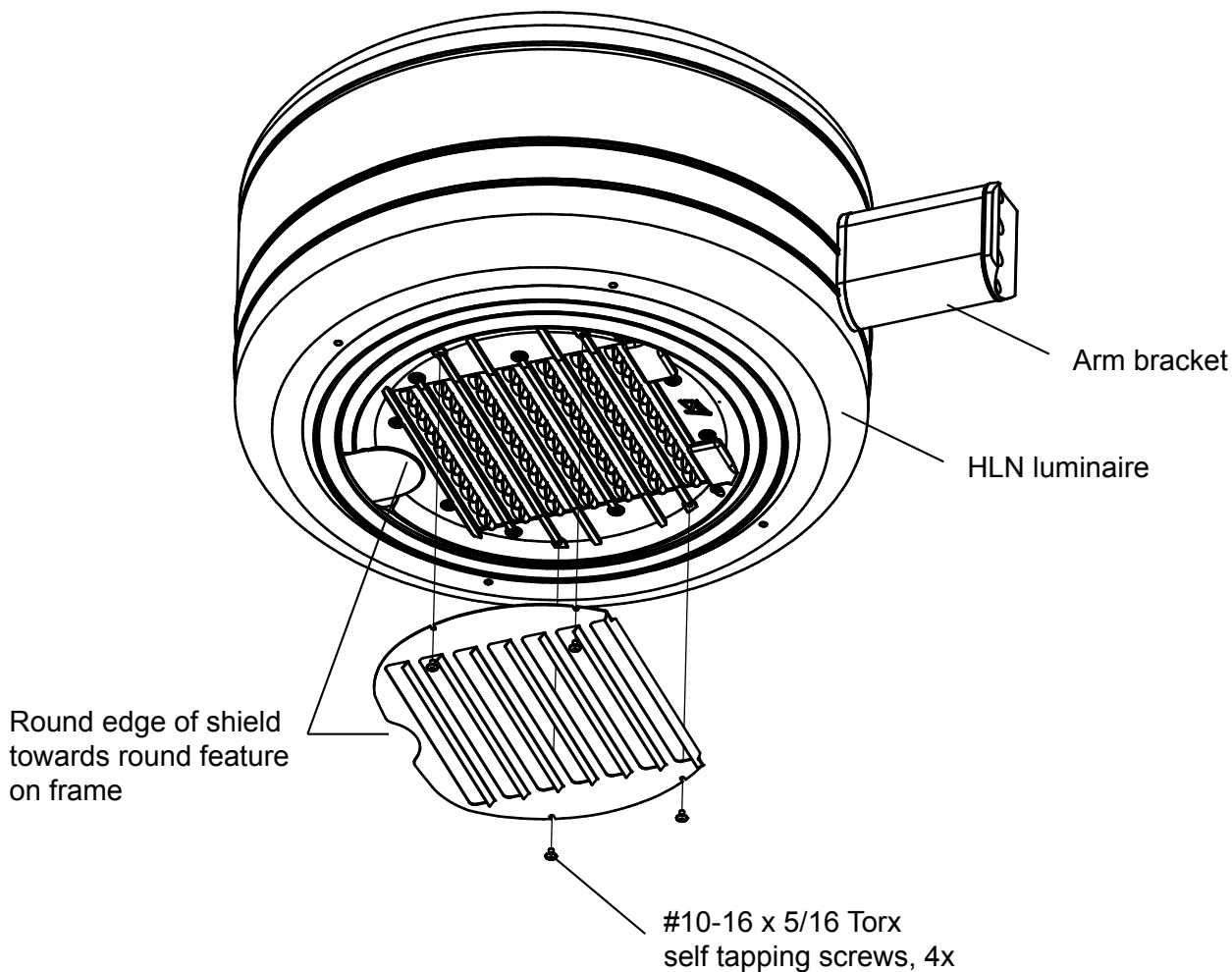

Installation Questions?
Call LSI Field Service Department at:
1-800-436-7800 Ext. 3300 Fax: (513) 793-0147



XCN4 Constitution Series Integral Louver House Side Shield Installation and Assembly Instructions

FOR HLN SERIES, SEE OPPOSITE SIDE!

WARNING - Risk of fire or electrical shock! Disconnect power before installing shield!

WARNING - Before proceeding, read all instructions carefully to ensure proper and safe installation!

1. Louver can only be mounted one way (follow illustration below for proper mounting orientation).
2. Kit contains one Integral Louver Shield and (4) self-threading Torx head screws.
3. Align screw clearance holes in shield with the predrilled holes in the lens frame casting.
4. Using a Torx screwdriver, tighten screws to 20 IN-LBS.
5. Installation of shield is now complete.

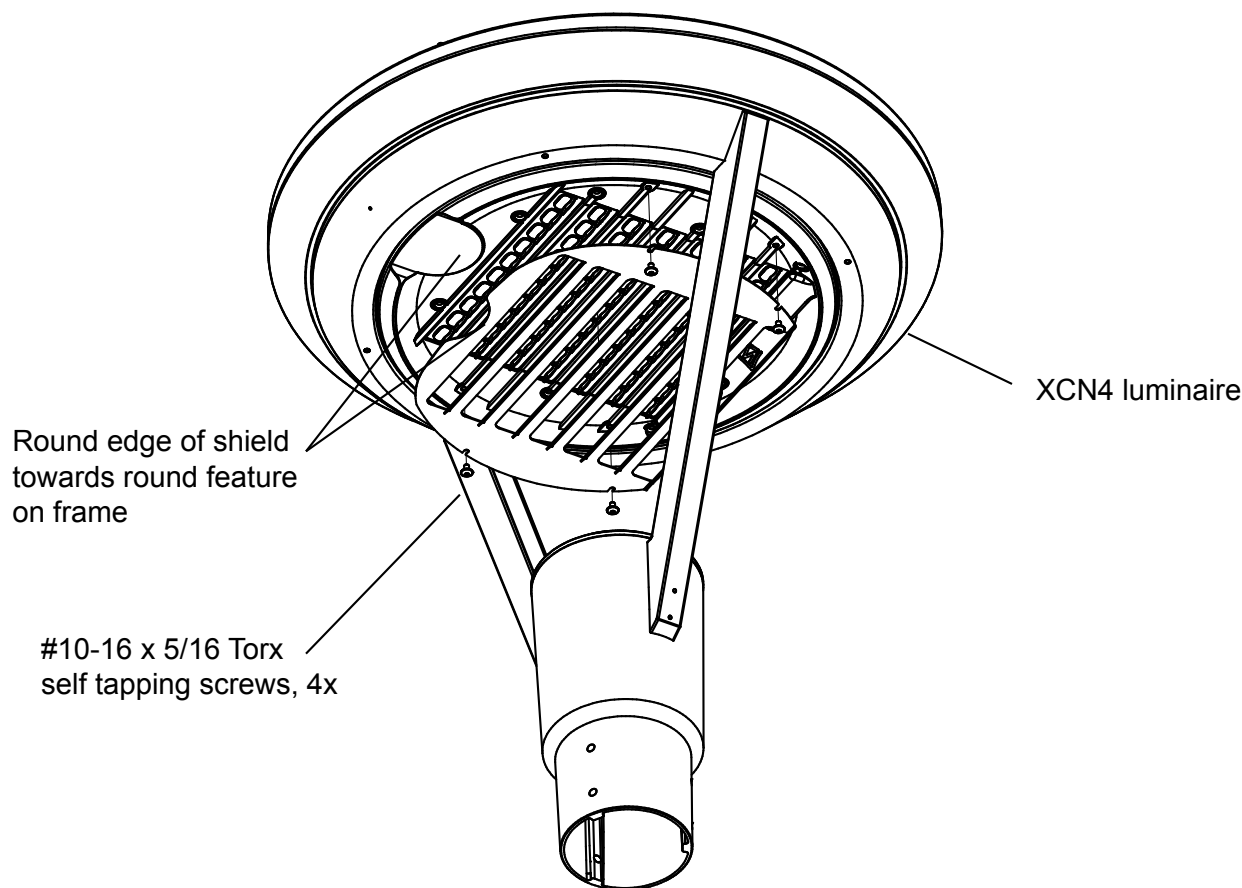

Installation Questions?

Call LSI Field Service Department at:
1-800-436-7800 Ext. 3300 Fax: (513) 793-0147

