

# EMERGENCY WIRELESS FIXTURE CONTROL RELAY 120/277 6A (EWFCR 6A)

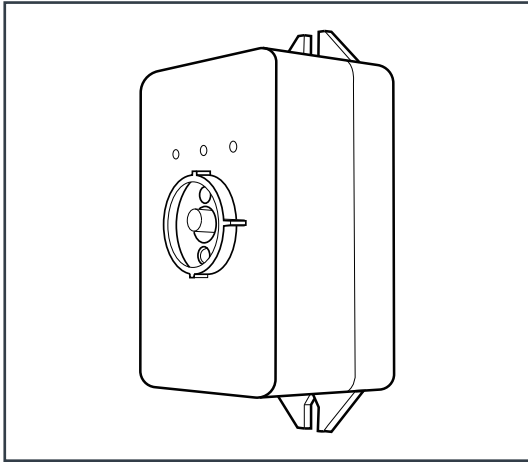

## SPECIFICATIONS

### ELECTRICAL

- UL924 Listed
- ARRA Compliant
- 120V/277V Dual Sensing Input
- Dry Contact Output
- N/O, N/C (Form C) Contact (#1)
- 20A Rating 120/277V
- N/O, N/C (Form C) Contact (#2)
- 6A Rating 30VDC

### MECHANICAL

- UL94V-0 Flame Rating
- Shipping Weight: 8oz
- Temperature: 32°F - 140°F
- Color: Black
- Limited Five-Year Warranty



## TROUBLESHOOTING & MAINTENANCE

If the EWFCR does not function properly on startup perform the following tests:

- Turn regular branch circuit breaker to “OFF” position and verify that connected loads behave as desired. If not, verify that N/O and N/C sides of contact have been wired properly.
- No maintenance is required to keep the EWFCR functional. However, regular testing should be performed when the lamps or ballasts have been replaced or when facility remodeling has taken place.
- The EWFCR can be installed above the suspended ceiling in a junction box or in the light fixture ballast channel. These mounting methods ensure the EWFCR is accessible, complying with all codes and requirements. The EWFCR can also be mounted in plenum, when tiles are removable.

## OVERVIEW

The UL924 Listed EWFCR 6A emergency shunt relay provides two dry N/O, N/C contact closures that changes position when there is a utility power interruption. It is uniquely suited for advanced control schemes that require a single bypass for each fixture, such as wireless fixture controls.

## FEATURES

- Dual sensing input dry contacts output, line voltage and 0–10V contacts
- The 6A Line Voltage Bypass Contact can be used for various purposes including shunting/ bypassing an emergency light switch, remote signaling of another control device
- The 1A Low Voltage Bypass contact is used for bypassing a 0–10V line to full brightness, fire alarm interface, and other low voltage/class 2 applications
- Includes momentary test switch and green utility power indicator LED
- Its small size is ideal for fixture mounting alongside wireless lighting controls

## IMPORTANT SAFEGUARDS

When using electrical equipment, basic safety precautions should always be followed:

1. This product can be used with ballast, tungsten and general use loads
2. Assure connections are in accordance with the National Electrical Code and local regulations
3. To avoid electric shock, disconnect both normal and emergency power supplies before servicing
4. This product is intended to be used to control indoor and outdoor located loads
5. An unswitched AC power source is required (120 or 277VAC)
6. Do not install near gas or electric heaters
7. Do not attempt to service a sealed Emergency Power Control.
8. The use of accessory equipment is not recommended by the manufacturer and may cause an unsafe condition
9. Do not use this product for other than intended use
10. Servicing should be performed by qualified service personnel
11. Equipment should be mounted in locations and at the heights where it will not readily be subjected to tampering by unauthorized personnel

## DIMENSIONS

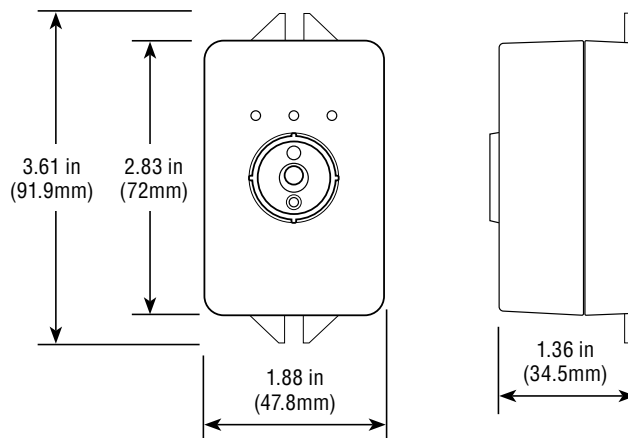

Project Name \_\_\_\_\_ Catalog # \_\_\_\_\_

1-800-436-7800 (Support, Option 8) [www.lsi-industries.com](http://www.lsi-industries.com)

01/18/18

© 2018  
LSI INDUSTRIES INC.

# EMERGENCY LIGHTING CONTROL RELAY 120/277 6A (EWFCR 6A)

## INSTALLATION

In order to install the EWFCR in accordance with national/local code requirements, a qualified electrician should review and understand the installation instructions: Check voltage and current requirements. Verify and lock out circuit breakers on both normal power and 24 hours emergency circuit. Install a self-adhesive 2in x 3in caution label in each fixture or load controlled by an EWFCR unit cautioning that this load is supplied from 2 different power sources, regular and emergency. Review wiring diagram and connect wires, one group at a time, in accordance with the numeric identification. The EWFCR is a universal mount unit, convenient and fast to install virtually anywhere.

## UNIVERSAL MOUNT

### Wall or Ceiling Installation

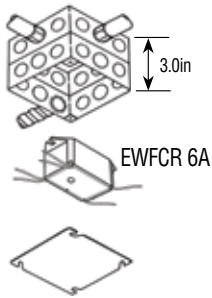

Recommended box size: 4.69in with blank cover

### Fire Ceiling Installation

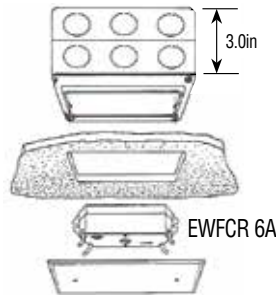

### Fixture Mount Installation

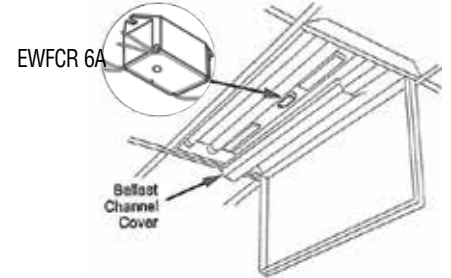

## WIRING DIAGRAMS

### Line Voltage & 0-10V Shunt Application

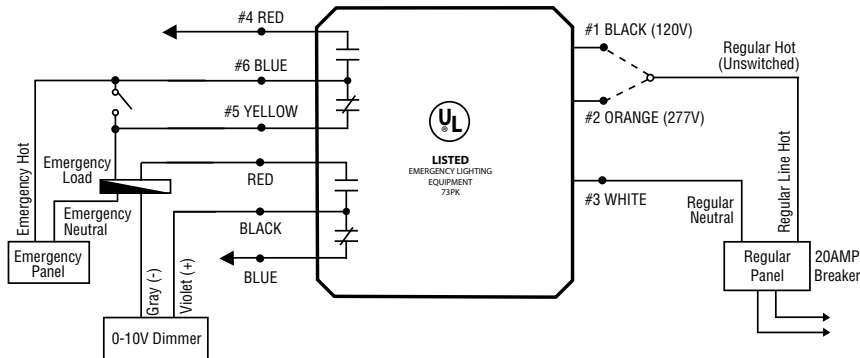

### Integrated Wireless Shunt Application

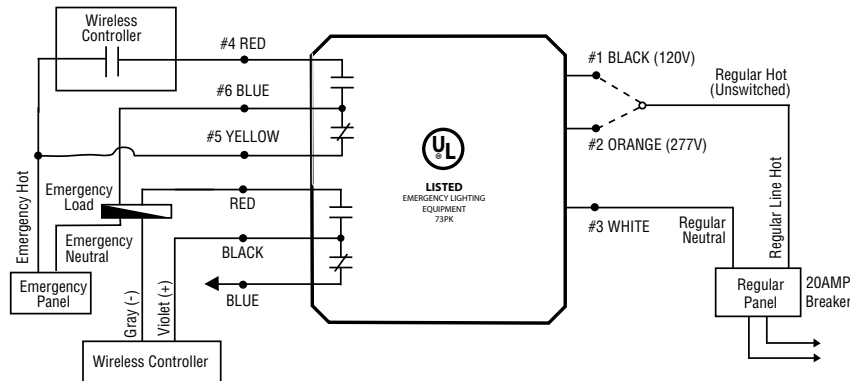

## ORDERING INFORMATION

PART NO.	CAT. NO.	DESCRIPTION
649124	EWFCR 6A	Emergency Wireless Fixture Control Relay 120/277 6A, Dual Sensing Input Dry Contacts Output, Line Voltage And 0-10V Contacts



Project Name \_\_\_\_\_ Catalog # \_\_\_\_\_

1-800-436-7800 (Support, Option 8) www.lsi-industries.com

01/18/18  
© 2018  
LSI INDUSTRIES INC.