

EMERGENCY LIGHTING CONTROL RELAY 120/277 6A WITH 0-10V DIMMING (ELCR 6A10D)

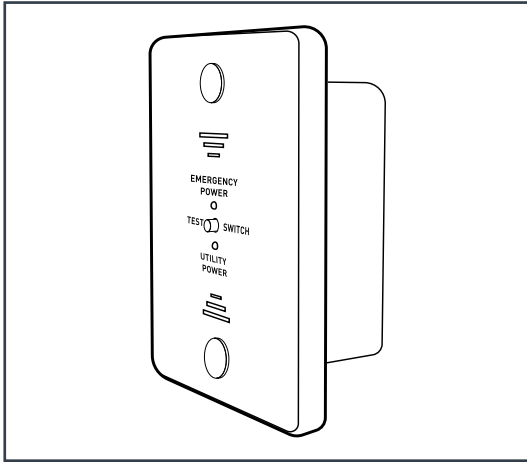

OVERVIEW

In the past, emergency lights were kept on 24 hours a day to meet life safety codes. Now, you can use a UL924 listed Emergency Power Control, Model ELCR 6A10D, to convert regular light fixtures into approved emergency lights. The ELCR allows switching/dimming of designated emergency luminaires during normal operation & automatically brings emergency luminaires to full brightness during a utility power interruption. Save energy and money while ensuring compliance with both life safety and energy codes.

During normal operation, the same room switch, occupancy sensor, relay panel, or lighting control switches regular and emergency fixtures on and off simultaneously.

During a utility power interruption, the ELCR automatically bypasses the regular lighting controls, turning the emergency lights ON, regardless of switch position.

The ELCR is ceiling or wall mounted in a junction box with a single gang plaster ring and is usually located in the area where the emergency fixtures are installed.

APPLICATIONS

- Hallways • Classrooms • Conference Rooms

SPECIFICATIONS

ELECTRICAL

- cULus UL924 Listed
- Dual Voltage: 120V/277V Sensing Input, 120V/277V Load
- 20A Ballast Load Rating
- 1800W (120V) / 1500W (277V) Incandescent Load
- Voltage Surge Protection

MECHANICAL

- 4.69" Junction Box w/ single gang ring
- UL94-5VA Rating: Safe for installation above the suspended ceiling
- Shipping Weight/Color: 8 oz. / White
- Temperature: 32°F - 140°F (0°C - 60°C)
- Limited Five-Year Warranty

FEATURES

- Unique, Patented Automatic Diagnostic Feature: When the room switch is turned off, the ELCR will run a 2.5 second self-test routine, verifying that the emergency power source was available and that the ELCR, ballast, and lamp(s) are all functioning correctly. This feature eliminates the need for time-consuming and costly manual monthly testing and is approved for this purpose. This also allows the unit to be installed in remote or inaccessible locations, because the unit does not rely on access to its manual test switch
- Fire Alarm, Remote Test & 0-10V Dimming Option
- Utility & Emergency Power Indicator LEDs
- Slim, attractive flush mount profile allows easy access to manual test switch and LEDs
- Emergency luminaire and red supervision LED will not illuminate if emergency supply is disconnected during normal operation. Provides immediately visible warnings

DIMENSIONS

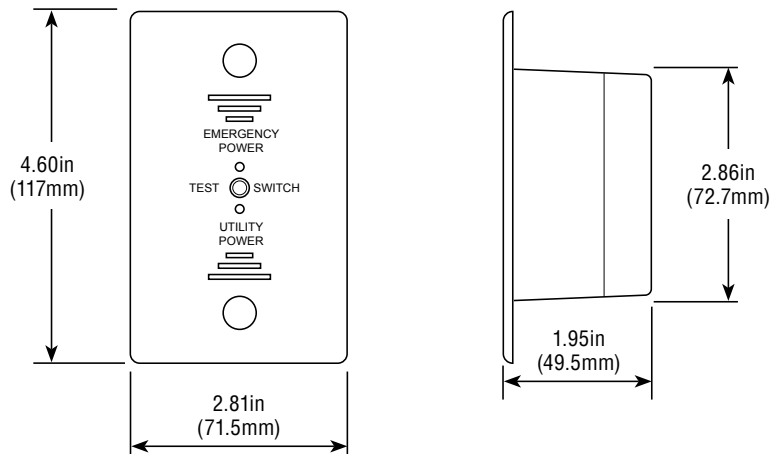

ORDERING INFORMATION

PART NO.	CAT. NO.	DESCRIPTION
649127	ELCR 6A10D	Emergency Lighting Control Relay 120/277 6A, Switched Load Override with 0-10V Dimming, Flush Mount



Project Name _____ Catalog # _____

1-800-436-7800 (Support, Option 8) www.lsi-industries.com

01/18/18
© 2018
LSI INDUSTRIES INC.

EMERGENCY LIGHTING CONTROL RELAY 120/277 6A WITH 0-10V DIMMING (ELCR 6A10D)

THEORY OF OPERATION

The emergency luminaire power is derived from a 24 hour central emergency power source. The local utility power company normally supplies the power through a UL1008 Transfer Switch or equal, but during a utility power failure, the transfer switch automatically switches to the emergency power source.

- Normal Operation:** The room switch turns on and off both regular and emergency luminaires simultaneously. This is accomplished by having the room switch leg power activate the Emergency Power Control, ELCR.
- Emergency Operation:** Wire input #1 or #2 and neutral are connected internally to a sensing circuit. During a power interruption on the sensing input, this circuit causes contact X to drop into a N.C. position and turns on the emergency load(s). Review wiring diagram, on reverse, for details.
- Automatic Diagnostic & Testing Operation:** When the zone control is turned off, such as at the end of the day, the emergency luminaires stay on at full brightness for 2.5 seconds & indicate that an emergency power source was available & that the ELCR, ballast, & lamp(s) are all functioning correctly. This satisfies the monthly test requirement required by law. When extended duration testing is desired, such as during initial start-up foot candle readings, the manual test button can be pressed.
- Emergency Power Clarification:** Emergency Line power is supplied at all times from a 24 hour emergency power panel. During normal time this panel is supplied with utility power. During a utility power failure, it is supplied with generator or equivalent power.

FLUSH-MOUNT CEILING INSTALLATION

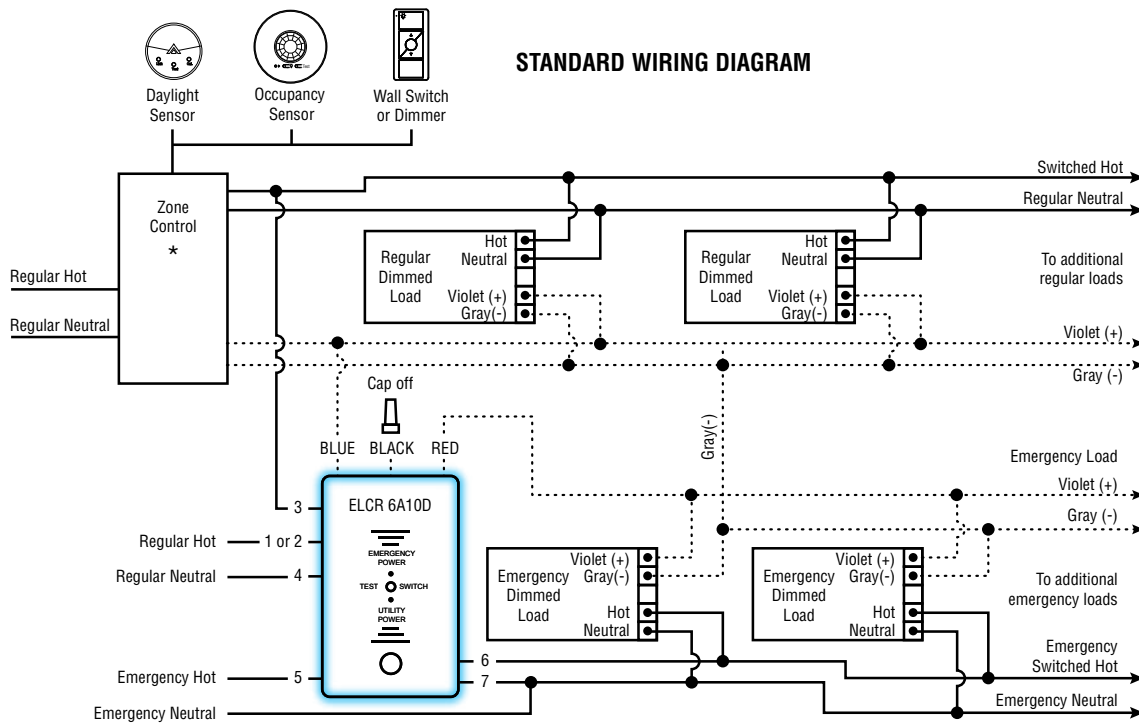
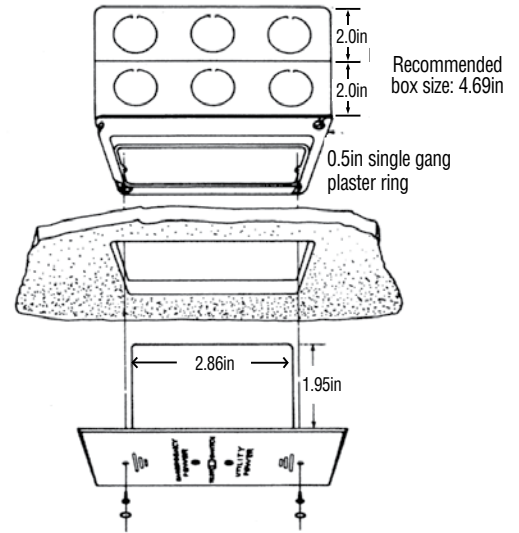

STANDARD WIRING DIAGRAM

* NOTE: Zone Control device can be any combination of the following:

- Intelligent zone controller including both low voltage dimming output & line voltage switching output.
- Line voltage switching devices (such as: occupancy sensor contact, time clock, relay panel) & low voltage dimming devices including daylight sensors, wall dimmers & other low voltage dimming signals (0-10V or digital)

REGULAR POWER WIRING		
WIRE #	COLOR	CONNECTION
1	BLACK	Regular Hot (120V)
2	ORANGE	Regular Hot (277V)
3	RED	Switched Hot
4	WHITE	Regular Neutral
5	BLUE	Regular Hot (120V)
6	YELLOW	Regular Hot (277V)
7	WHITE/BLUE STRIPE	Switched Hot

PLENUM CABLE B LOW VOLTAGE WIRING	
BLUE	Dimmer Violet (+)
RED	Emergency Load Violet (+)
BLACK	Cap off



EMERGENCY LIGHTING CONTROL RELAY 120/277 6A WITH 0-10V DIMMING (ELCR 6A10D)

INITIAL TESTING AND TROUBLESHOOTING

In a new installation, where 10 or 100 separate devices may be used, each having as many as 14 wires to be correctly connected, it is important that a fast convenient method is used to check the connections. In order to test that the wires are connected correctly, without any inconvenience to other occupants, do not turn off regular utility supplied power or turn on the emergency generator until you have checked each ELCR device and light fixtures using the following methods.

TROUBLESHOOTING & MAINTENANCE

When the normal room or area switch is on, emergency load and regular load fixtures should all be illuminated. If ELCR 6A10D does not function properly on startup perform the following tests:

1. To test normal operation, ensure branch circuit breaker is connected and utility power is available. If green LED is not illuminated, confirm wiring connections and continuity to branch panels.
2. To test emergency operation, ensure emergency source is connected and red LED is illuminated. Turn room switch to "OFF" position, and ensure

that emergency lights stay illuminated for at least 2.5 seconds. If emergency lights do not stay on for at least 2.5 seconds, confirm wiring connections and perform testing on emergency panel and emergency power source.

No maintenance is required to keep the ELCR 6A10D functional. However, regular testing should be performed when the lamps or ballasts have been replaced or when facility remodeling has taken place.

FREQUENTLY ASKED QUESTIONS

Question: What if there is only 1 light fixture in the room? What if all light fixtures are emergency fixtures?

Answer: Follow the standard wiring diagram on page 2. Treat the fixture(s) as "emergency dimmed loads" & follow standard wiring diagram on page 2. "Regular dimmed load" is not used in this application.

Question: What if using a digital low voltage dimmer control & ballasts, such as DALI protocol?

Answer: Follow the standard wiring diagram on page 2. Violet and Gray leads will be designated as "D1,D2" or equivalent for digital low voltage signal.

If no line voltage switch is used, see Alternate Wiring C, on page 4.

SINGLE LINE DRAWINGS

On a 20AMP circuit, 1 emergency power control (ELCR 6A10D) can control up to 20AMP of emergency lighting load, or 20 emergency power controls can each control 6AMP of emergency lighting load.

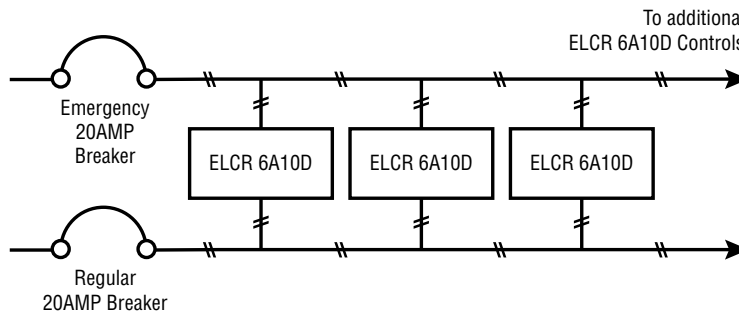

STANDARD ZONE CONTROLLER LINE DRAWING

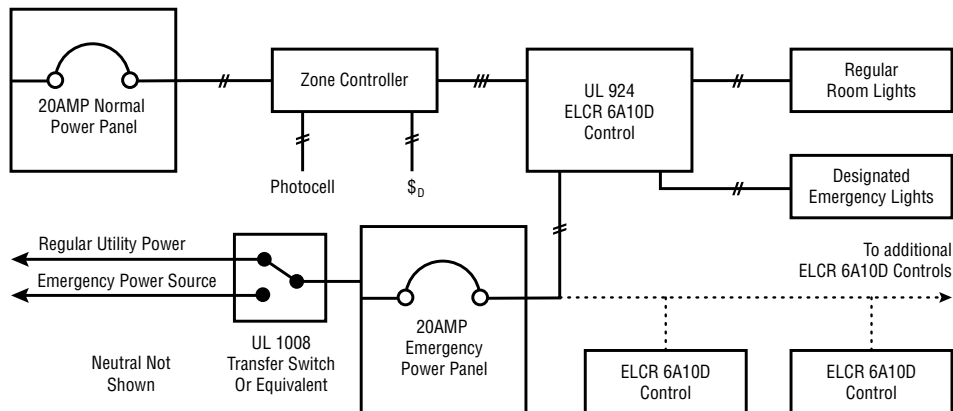

EMERGENCY LIGHTING CONTROL RELAY 120/277 6A WITH 0-10V DIMMING (ELCR 6A10D)

SPECIAL APPLICATIONS/ALTERNATE WIRING DIAGRAMS

The wide range of 0-10V controls and loads available has led to a number of different requirements and standards. The ELCR 6A10D is designed to accommodate many alternate or special applications, and to ensure proper operation for all ballast or controller manufacturers.

A

When grounding the low voltage input of a ballast is required during emergency operation:
Use Alternate Diagram "A." Plenum Cable B Black to ground, all line voltage leads are identical.

B

When a minimum resistive load is required on the low voltage input of a ballast during emergency operation:
Use Alternate Diagram "B." Connect a resistor (minimum resistance 75KΩ) between Plenum Cable B black lead and gray input of emergency ballasts, all line voltage leads are identical.

C

When using a digital low voltage dimmer control with no line voltage switching:
Use Alternate Diagram "C." Please note that for this application the automatic diagnostic feature does not function, therefore manual monthly testing is required by NEC.

ALTERNATE WIRING DIAGRAM "A"

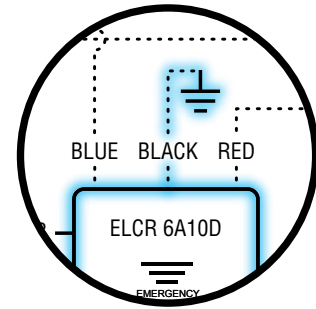

ALTERNATE WIRING DIAGRAM "B"

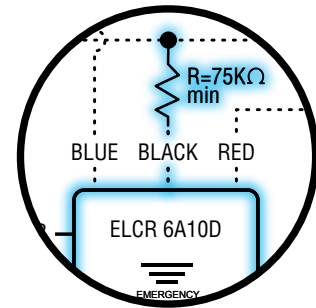

ALTERNATE WIRING DIAGRAM "C"

