

49" HIGH-VISIBILITY REMOTE REFRIGERATED UPRIGHT CASES

AVAILABLE IN 6' - 12' LENGTHS

Critical
TEMP



49" HIGH-VISIBILITY REFRIGERATED UPRIGHT CASES

DESCRIPTION

JSI's critical temp Refrigerated Upright Cases are available in our full range of styles and finish options to perfectly match your entire department. The low front design allows for maximum product visibility and a variety of merchandising options.

BEST USED FOR

- Front Entry
- Island Groupings
- Mix & Match with Refrigerated and Ambient Fixtures
- Berries

FEATURES



LOW 16" DECK HEIGHT

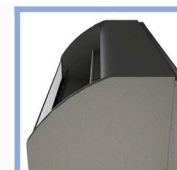

SLEEK, CURVED SIDES AND HOOD

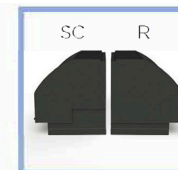

SAME PROFILE, SELF CONTAINED OR REMOTE

STANDARD FEATURES

- High Efficiency Motors
- Digital Solar Thermometer
- Removable Service Panels
- Electronic Control
- Designed to Maintain Product Temperatures at <41° F
- Electric Condensate Pan

OPTIONAL ACCESSORIES

- Metal Toe kicks
- 12", 15", and 17" deep LED lit Shelves
- Corner Guards and Bumper
- Adjustable Wire Deck
- Foam Pad
- Price Tag Molding
- Magnetic Filter Screen
- Available in many laminates, or with front accent trim.

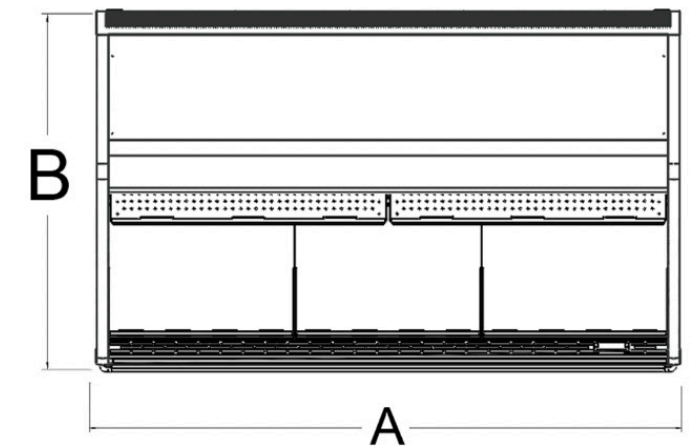
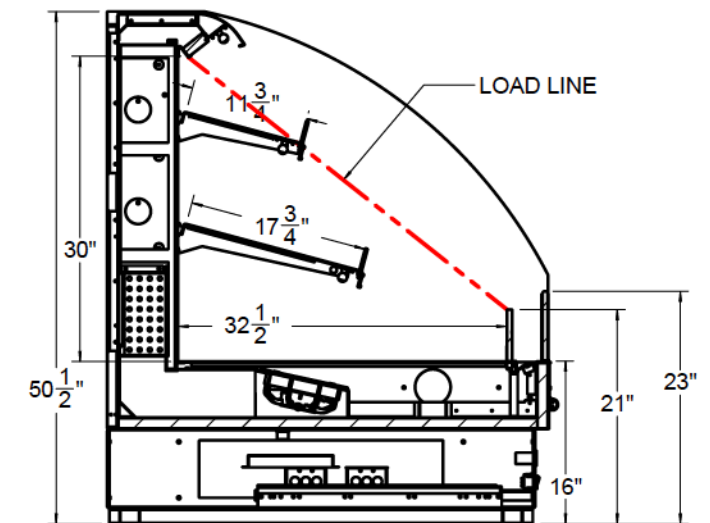

MODEL	DIMENSIONS*		POWER						
	A	B	V	Ph	Hz	MCA	MOP	HP	BTU/hr @ 75F
RBS146HVB-49	75 1/2"	45 1/2"	208	1	60	15.3	20	3/4	7660
RBS148HVB-49	99"	45 1/2"	208	1	60	18.5	25	1	9180
RBS1410HVB-49	123"	45 1/2"	208	1	60	21.3	25	1 1/4	11900
RBS1412HVB-49	147"	45 1/2"	208	1	60	23.3	30	1 1/4	11900



140 Park Street • Milo, Maine 04463 • 800.332.5507 TEL • 207.943.5632 FAX • JSISTOREFIXTURES.COM

Milo, Maine • Bangor, Maine • Payson, Utah • Collingwood, Ontario

Please refer to our "Styles, Groupings, Stains and Accessories" brochure to see our wide range of materials, finishes, merchandising foam, and accessories.

*Dimensions are approximate and will vary based on wrap styles