

V-SERIES HIGH VISIBILITY REMOTE REFRIGERATED CASE

CRITICAL
TEMP



V-SERIES HIGH VISIBILITY REMOTE CASE

DESCRIPTION

Our V-Series refrigerated display cases bring added value to any program and are available in metal finishes.

BEST USED FOR

- Spot Merchandising
- Promotional displays
- Convenience stores
- Prepackaged meals

FEATURES

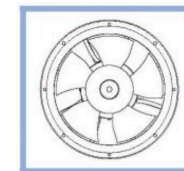

HIGH-EFFICIENCY
MOTORS

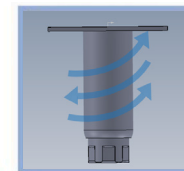

ADJUSTABLE
LEVELERS



MAINTAINS CRITICAL
TEMPERATURE

STANDARD FEATURES

- High Efficiency Motors
- High Efficiency Condensing Unit
- Removable Service Panels
- Electronic Control
- Designed to Maintain Product Temperatures at <41° F
- Electric Condensate Pan

OPTIONAL ACCESSORIES

- Corner Guards
- Corner Brackets
- Black Bumper
- Various Product Risers
- Magnetic Filter Screen
- 12" and 15" Adjustable Metal Shelves

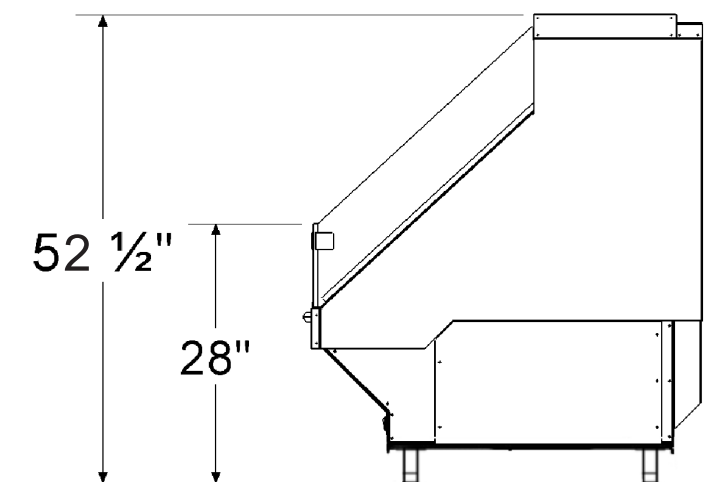
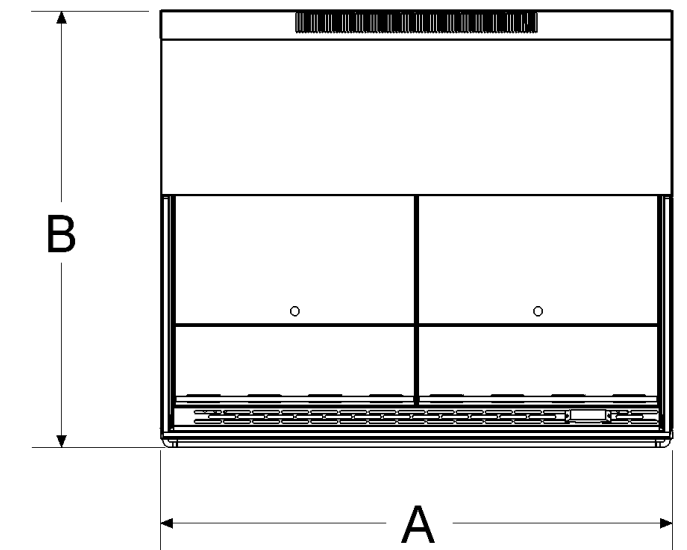

MODEL	DIMENSIONS*		POWER						
	A	B	V	Ph	Hz	MCA	MOP	HP	BTU/hr @ 75F
RBS134HV	52 1/2"	42 3/4"							



2017
DOE
COMPLIANT

140 Park Street • Milo, Maine 04463 • 800.332.5507 TEL • 207.943.5632 FAX • JSISTOREFIXTURES.COM

Milo, Maine • Bangor, Maine • Payson, Utah • Collingwood, Ontario

Please refer to our "Styles, Groupings, Stains and Accessories" brochure to see our wide range of materials, finishes, merchandising foam, and accessories.

*Dimensions are approximate and will vary based on wrap styles