

FRESH TO GO REFRIGERATED ROUND CASES

TYPE II CERTIFIED



Critical
TEMP

FRESH TO GO REFRIGERATED ROUND CASES

DESCRIPTION

Fresh To Go is our new line of refrigerated merchandisers that accommodate almost any store layout. These can be merchandised from 270, or a full 360 degrees! Adjust shelving up or down to create the perfect display.

BEST USED FOR

- Spot Merchandising
- Promotional displays
- Convenience stores
- Prepackaged meals

FEATURES



HEIGHT ADJUSTABLE
SHELVES

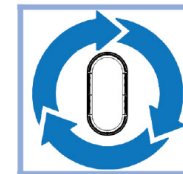

360° OF
MERCHANDISING



EASY ACCESS
CONTROLS

STANDARD FEATURES

- High Efficiency Motors
- Digital Solar Thermometer
- Removable Service Panels
- Electronic Control
- Designed to Maintain Product Temperatures at <41° F
- Electric Condensate Pan

OPTIONAL ACCESSORIES

- LED canopy lighting
- LED shelf lighting
- Custom Powdercoat options
- "Organics" product stops

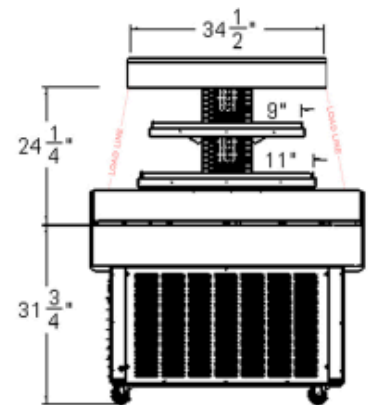
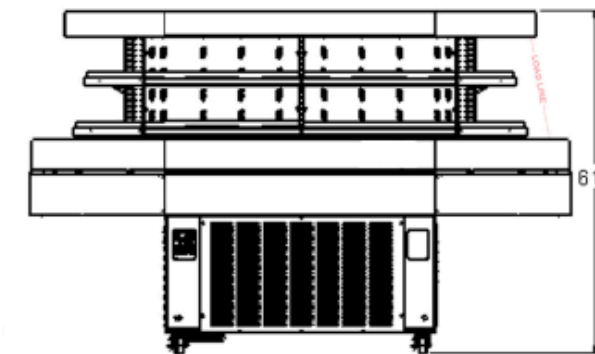
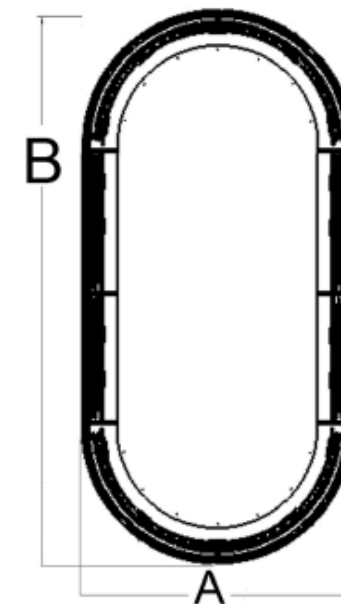

MODEL	DIMENSIONS*		POWER						
	A	B	V	Ph	Hz	MCA	MOP	HP	BTU/hr @ 90F
RIU048-62-F	48 1/2"	96"	208	1	60	40.8	60	2 1/2	23600

Please refer to our "Styles, Groupings, Stains and Accessories" brochure to see our wide range of materials, finishes, merchandising foam, and accessories.

*Dimensions are approximate and will vary based on wrap styles



140 Park Street • Milo, Maine 04463 • 800.332.5507 TEL • 207.943.5632 FAX • JSISTOREFIXTURES.COM

Milo, Maine • Bangor, Maine • Payson, Utah • Collingwood, Ontario