

# 2-TIER HIGH-VISIBILITY REFRIGERATED CASE



**7.5\"/>**

## 2-TIER HIGH-VISIBILITY REFRIGERATED CASE

### DESCRIPTION

JSI's Refrigerated Cases will help reduce shrink and drive sales higher in your fresh departments. These merchandisers are available in our full range of styles and finish options to perfectly match your store's décor.

### BEST USED FOR:

- Spot Merchandising
- Front Entry
- Mix & Match with Refrigerated and Ambient Fixtures
- Critical Temp Product

### FEATURES

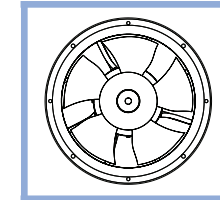

High-Efficiency Fan Motors

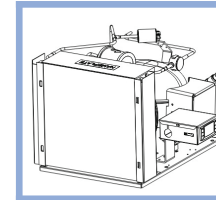

High-Efficiency Condensing Unit

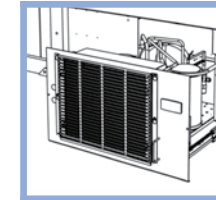

Slide-Out Service Drawer

### STANDARD FEATURES

- Electronic Control
- Removable Service Panels
- Digital Solar Thermometer
- Designed to Maintain Product Temperatures at <41°F
- Electric Condensate Pan

### OPTIONAL ACCESSORIES

- Corner Guards
- Corner Brackets
- Black Bumper
- Various Product Risers
- Magnetic Filter Screen
- Available in metal or wood wrap and in a variety of finishes

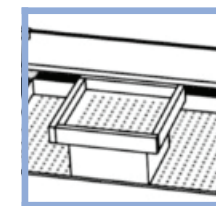

Pedestal Riser

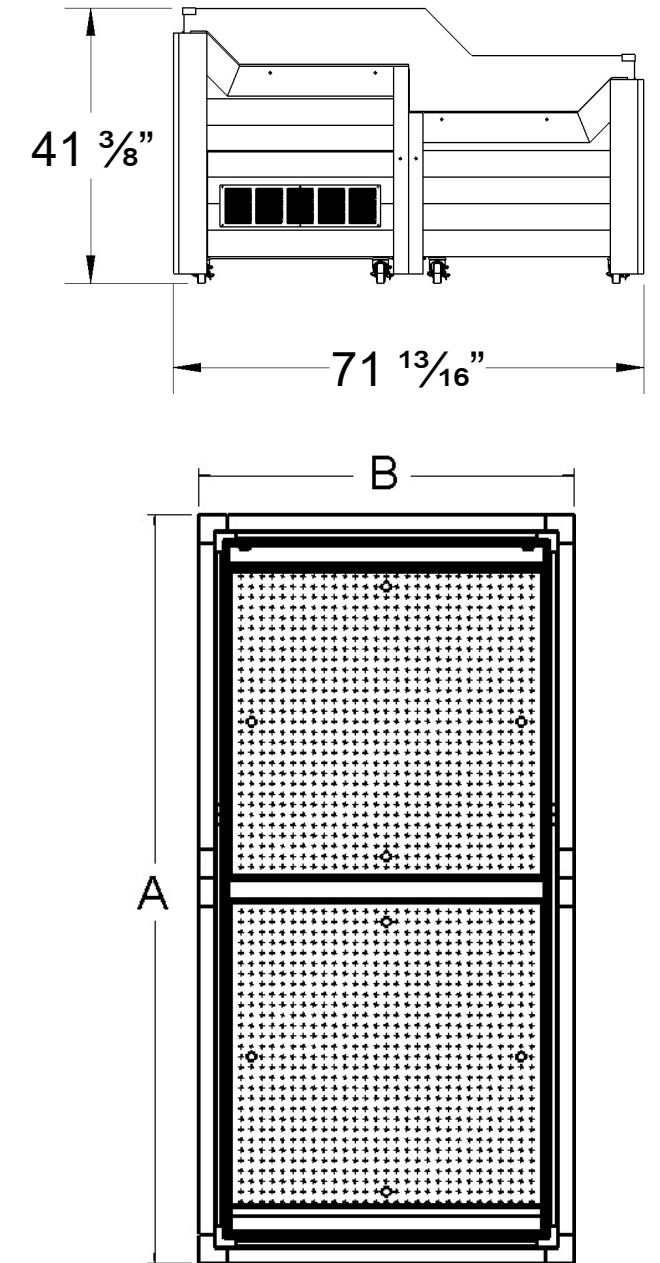

140 Park Street • Milo, Maine 04463 • 800.332.5507 TEL • 207.943.5632 FAX • [JSISTOREFIXTURES.COM](http://JSISTOREFIXTURES.COM)  
 Milo, Maine • Bangor, Maine • Payson, Utah • Collingwood, Ontario

MODEL	DIMENSIONS*		POWER						
	A	B	V	Ph	Hz	MCA	MOP	HP	BTU/hr @ 75F
RBD0362HV	72"	36"	120	1	60	18.2	25	½	4750

Please refer to our "Styles, Groupings, Stains and Accessories" brochure to see our wide range of materials, finishes, merchandising foam, and accessories.  
 \*Dimensions are approximate and will vary based on wrap styles

