

49" HIGH VISIBILITY REFRIGERATED SLANT CASE

AVAILABLE IN 6' - 12' LENGTHS

CRITICAL TEMP



140 Park Street • Milo, Maine 04463 • 800.332.5507 TEL • 207.943.5632 FAX • JSISTOREFIXTURES.COM

Milo, Maine • Bangor, Maine • Payson, Utah • Collingwood, Ontario

JSISTOREFIXTURES.COM

49" HIGH VISIBILITY REFRIGERATED SLANT CASE

DESCRIPTION

JSI's R290 Refrigerated Slant Cases keep products fresh and visually enticing with precise temperature control and a sleek, energy-efficient design. Available in our full range of styles and finish options.

BEST USED FOR

- Spot Merchandising
- Front Entry
- Mix & Match with Refrigerated and Ambient Fixtures
- Critical Temp Product

STANDARD FEATURES

- High Efficiency Motors
- Digital Solar Thermometer
- Removable Service Panels
- Electric Condensate Pan
- Designed to Maintain Product Temperatures at <41°F
- Cleanable Magnetic Filters

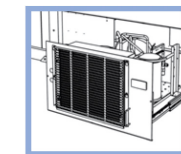

SLIDE OUT SERVICE DRAWER

OPTIONAL ACCESSORIES

- Corner Guards and Brackets
- Adjustable Wire Deck
- Foam Pad
- Price Tag Molding
- Merchandising Steps
- Various Shelf Styles and Sizes
- Magnetic Filter Screen
- Available in a variety of materials and finishes

FEATURES



LOW GWP NATURAL REFRIGERANT



ELECTRONIC CONTROLS

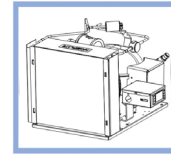

HIGH EFFICIENCY CONDENSING UNIT

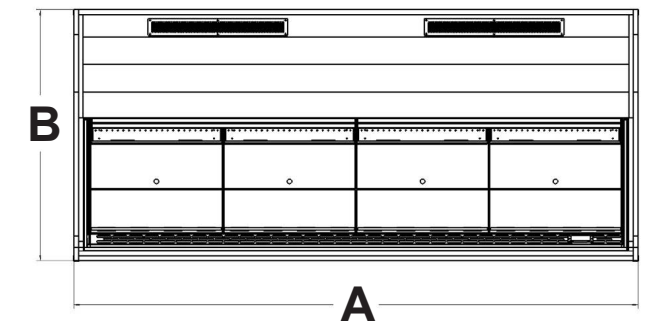
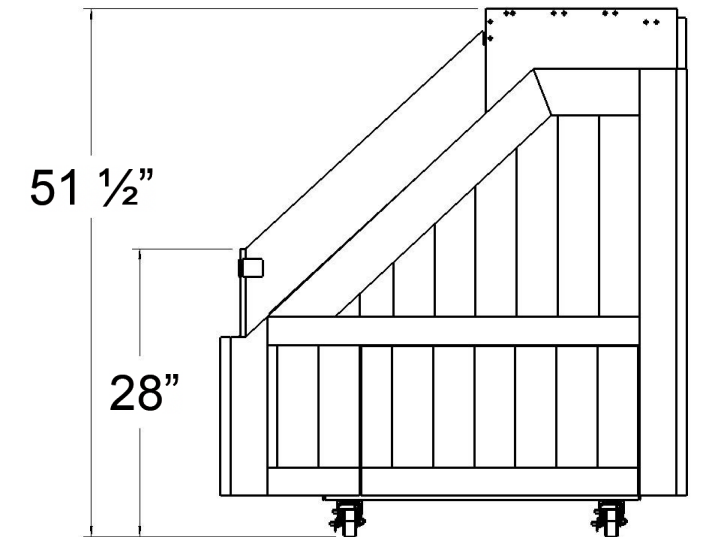

MODEL	DIMENSIONS*		POWER						
	A	B	V	Ph	Hz	MCA	MOP	HP	BTU/hr @ 75F
RBS033HV-49	39"	45"	120	1	60	13.7	15	1/2	5470
RBS034HV-49	51"	45"	120	1	60	13.7	15	1/2	5470
RBS036HV-49	75"	45"	208	1	60	20.2	25	1	10100
RBS038HV-49	99"	45"	208	1	60	20.3	25	1	10100
RBS0310HV-49	123"	45"	208	1	60	22.0	30	1 1/4	13100
RBS0312HV-49	147"	45"	208	1	60	22.1	30	1 1/4	13100

Please refer to our "Styles, Groupings, Stains and Accessories" brochure to see our wide range of materials, finishes, merchandising foam, and accessories.

*Dimensions are approximate and will vary based on wrap styles



2017 JOE COMPLIANT

JSISTOREFIXTURES.COM