

56" H HIGH-VISIBILITY REFRIGERATED SLANT CASES

AVAILABLE IN 6' - 10' LENGTHS

Critical
TEMP



56" H HIGH-VISIBILITY REFRIGERATED SLANT CASES

DESCRIPTION

JSI's critical temp Refrigerated Slant Cases are available in our full range of styles and finish options to perfectly match your entire department. The low front design allows for maximum product visibility and a variety of merchandising options.

BEST USED FOR:

- Front Entry
- Island Groupings
- Mix & Match with Refrigerated and Ambient Fixtures
- Berries

FEATURES



Electronic Controls

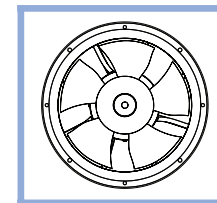

High-Efficiency Fan Motors

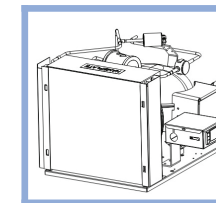

High-Efficiency Condensing Unit

STANDARD FEATURES

- High Efficiency Motors
- Digital Solar Thermometer
- Removable Service Panels
- Electronic Control
- Designed to Maintain Product Temperatures at <41°F
- Electric Condensate Pan

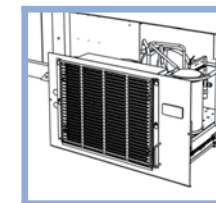

Slide-Out Service Drawer

OPTIONAL ACCESSORIES

- Merchandising Steps
- Various Shelf Styles and Sizes
- Corner Guards and Brackets
- Adjustable Wire Deck
- Foam Pad
- Price Tag Molding
- Magnetic Filter Screen
- Available in metal or wood wrap and in a variety of finishes

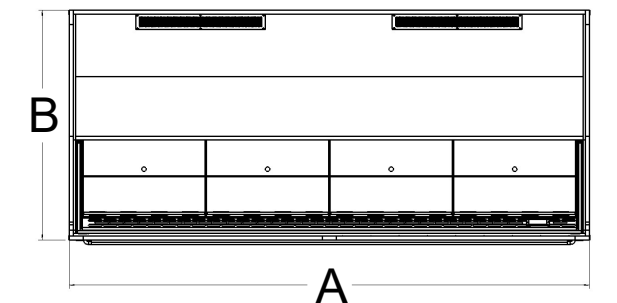
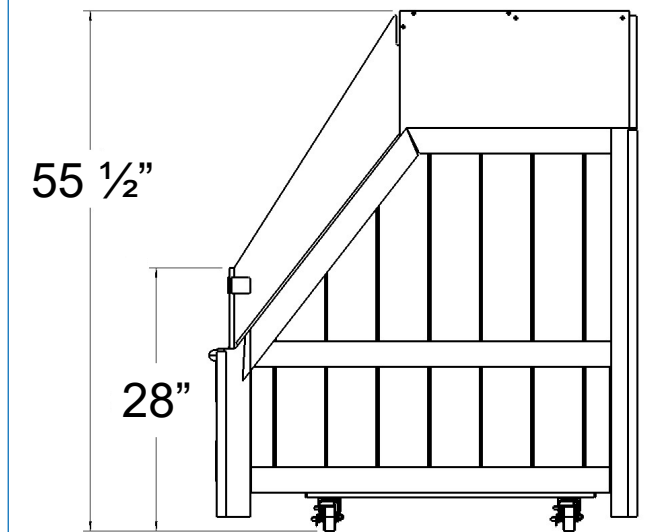

MODEL	DIMENSIONS*		POWER						
	A	B	V	Ph	Hz	MCA	MOP	HP	BTU/hr @ 75F
RBS036HV-56	74 1/2"	44 1/2"	208	1	60	15.3	20	3/4	7660
RBS038HV-56	101"	44 1/2"	208	1	60	18.5	25	1	9180
RBS0310HV-56	125 1/2"	44 1/2"	208	1	60	21.3	25	1 1/4	11900

