

# 62" H HIGH-VISIBILITY REFRIGERATED SLANT CASES

AVAILABLE IN 2' - 4' LENGTHS

Critical  
TEMP



## 62" H HIGH-VISIBILITY REFRIGERATED SLANT CASES

### DESCRIPTION

JSI's critical temp Refrigerated Slant Cases are available in our full range of styles and finish options to perfectly match your entire department. The low front design allows for maximum product visibility and a variety of merchandising options.

### BEST USED FOR:

- Spot Merchandising
- Front Entry
- Mix & Match with Refrigerated and Ambient Fixtures
- Critical Temp Product

### FEATURES



Electronic Controls

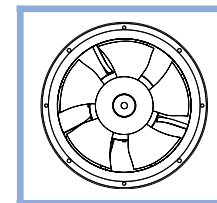

High-Efficiency Fan Motors

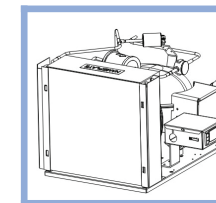

High-Efficiency Condensing Unit

### STANDARD FEATURES

- High Efficiency Motors
- Digital Solar Thermometer
- Removable Service Panels
- Electronic Control
- Designed to Maintain Product Temperatures at <41°F
- Electric Condensate Pan

### OPTIONAL ACCESSORIES

- Merchandising Steps
- Various Shelf Styles and Sizes
- Corner Guards and Brackets
- Adjustable Wire Deck
- Foam Pad
- Price Tag Molding
- Magnetic Filter Screen
- Available in metal or wood wrap and in a variety of finishes

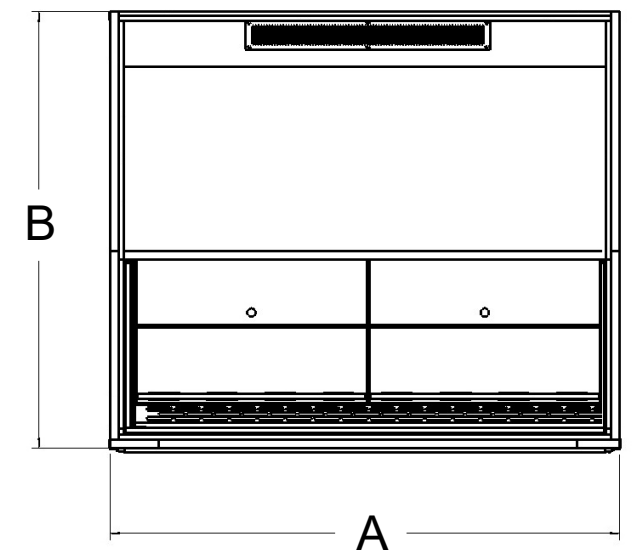
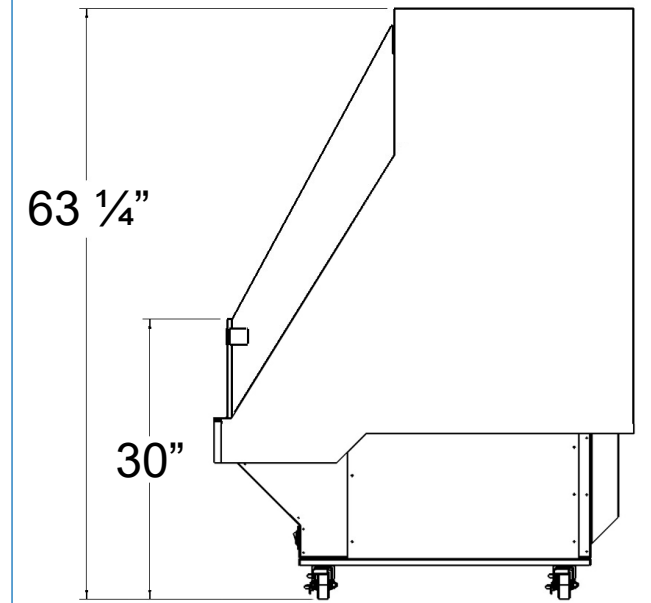

MODEL	DIMENSIONS*		POWER						
	A	B	V	Ph	Hz	MCA	MOP	HP	BTU/hr @ 75F
RBS032HV-62	24"	36"	120	1	60	12.7	20	1/3	3300
RBS033HV-62	38"	42"	120	1	60	12.7	20	1/3	3300
RBS034HV-62	50 1/2"	44 1/2"	120	1	60	19	25	1/2	5280



2017  
DOE  
COMPLIANT

 **JSI** Delivering a fresh experience