

2-TIER REFRIGERATED ORCHARD BIN

CRITICAL TEMP



2-TIER REFRIGERATED ORCHARD BIN

DESCRIPTION

Our 2-Tier Refrigerated Orchard Bins are the ultimate grab-and-go solution for fresh prepared foods. Keep products fresh and visually enticing with precise temperature control and a sleek, energy-efficient design.

BEST USED FOR

- Spot Merchandising
- Front Entry
- Mix & Match with Refrigerated and Ambient Fixtures
- Critical Temp Product

FEATURES



LOW GWP NATURAL REFRIGERANT



ELECTRONIC CONTROLS

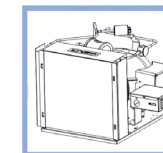

HIGH EFFICIENCY CONDENSING UNIT

STANDARD FEATURES

- Electronic Control
- Removable Service Panels
- Digital Solar Thermometer
- Designed to Maintain Product Temperatures at <41°F
- Electric Condensate Pan

OPTIONAL ACCESSORIES

- Corner Guards
- Corner Brackets
- Black Bumper
- Various Product Risers
- Magnetic Filter Screen
- Available in a variety of styles and finishes

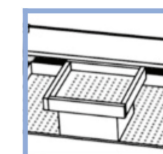

PEDESTAL RISER

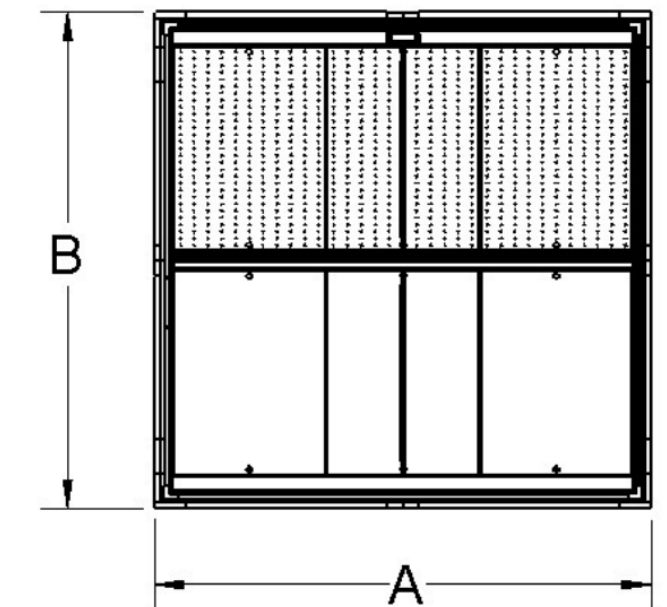
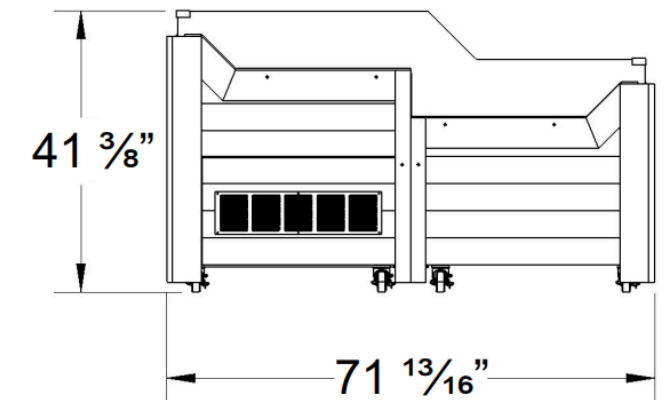

MODEL	DIMENSIONS*		POWER						
	A	B	V	Ph	Hz	MCA	MOP	HP	BTU/hr @ 75F
RBD0362	72"	36"	120	1	60	13.6	15	1/2	5470
RBD0552	60"	60"	208	1	60	15.5	20	3/4	8480
RBD0662	72"	72"	208	1	60	15.5	20	3/4	8480



140 Park Street • Milo, Maine 04463 • 800.332.5507 TEL • 207.943.5632 FAX • JSISTOREFIXTURES.COM
Milo, Maine • Bangor, Maine • Payson, Utah • Collingwood, Ontario

Please refer to our "Styles, Groupings, Stains and Accessories" brochure to see our wide range of materials, finishes, merchandising foam, and accessories.

*Dimensions are approximate and will vary based on wrap styles

