



REMOTE REFRIGERATION CATALOG



ONE PARTNER. COMPLETE REFRIGERATION SOLUTIONS.

Together with Carter, LSI brings customers a broader refrigerated display offering that now includes **remote refrigeration solutions**. This expanded portfolio provides more choice, greater design flexibility, and stronger support for creating high performing grocery and retail environments.



FD Cabinet

Full Glass Door



PRODUCT OVERVIEW

Our full height glass doored cabinet combines sleek aesthetics with powerful performance, making it the ultimate frozen food solution for modern stores. Includes (5) 22" deep shelves including price tag moulding as standard.

Choose from water-cooled, air-cooled and remote refrigeration options.

Available in 62", 92" 123" and 154" lengths.

FEATURES

- Frozen food - 75F @55%RH
- Remote, Air Cooled, and Water Cooled options
- Available as 2 , 3, 4 and 5 Door
- Danfoss or RDM
- Solid or Wire shelves
- Vertical lighting
- End walls specified per customer
- (5) 22" Shelves Plus, Base
- Ticket strip and optional Shelf risers
- EC EBM fans
- Electronic controller
- Mullion lighting
- Automatic defrost
- Multiplexable
- Solenoid valves as standard
- RAL exterior specified per customer
- RAL interior specified per customer
- End user specific colours & finishes available



DIMENSIONS

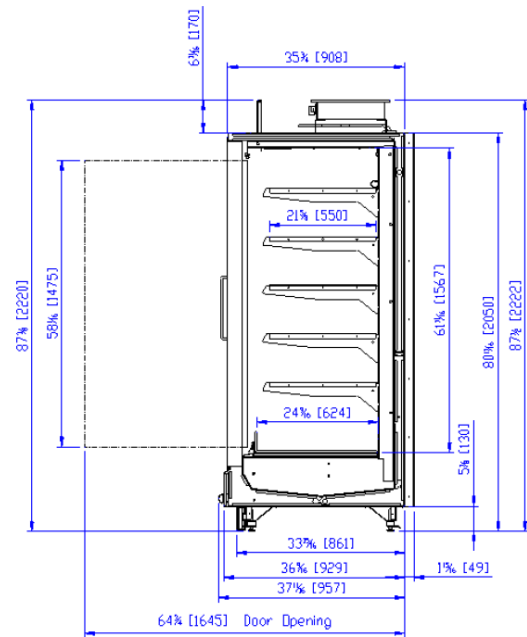

Model	Height	Width (Ex. End)	End Wall Thickness	Depth
FD Cabinet	80.7"	154"	1.25" or 2"	36.6"
FD Cabinet	80.7"	123"	1.25" or 2"	36.6"
FD Cabinet	80.7"	92"	1.25" or 2"	36.6"
FD Cabinet	80.7"	62"	1.25" or 2"	36.6"

IB Cabinet

Multi-Deck



PRODUCT OVERVIEW

The IB is our deepest open multi deck case designed for large format stores. It is high performance, high efficiency commercial refrigeration solution engineered for maximum merchandise capacity and product visibility.

Designed for flexibility and sustainability, the IB is available configured for use with HFC or CO2 direct expansion rack system, or as an R290 water cooled integral solution where racks are not applicable.

Available in 4', 6', 8', 10' and 12' lengths.

FEATURES

- Temperature range 32F/39F
- R744: Remote
- HFC: Remote
- R290: Self-contained
- Solid, mirrored end walls
- Plexiglass dividers or intermediate ends available for segmentation
- 24" shelf depth
- Various control strategies available
- Canopy and shelf lighting
- Night Blind
- Range of all real colours available
- Aerofoil technology available as an ancillary



DIMENSIONS

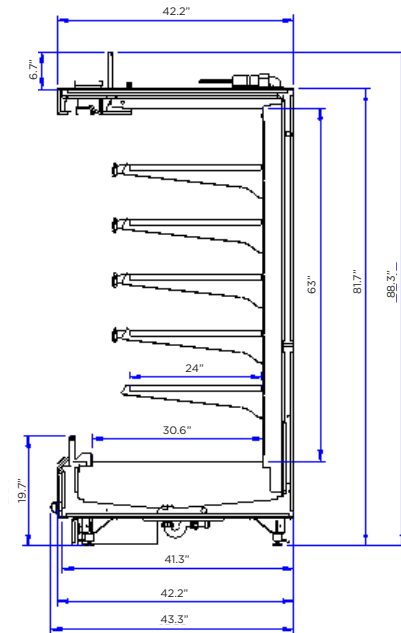

Model	Height	Width (Ex. End)	End Wall Thickness	Depth
IB Cabinet	81.7"	147.6"	1.25" or 2"	42.2"
IB Cabinet	81.7"	98.4"	1.25" or 2"	42.2"
IB Cabinet	81.7"	84.1"	1.25" or 2"	42.2"
IB Cabinet	81.7"	73.8"	1.25" or 2"	42.2"
IB Cabinet	81.7"	49.2"	1.25" or 2"	42.2"

IC Cabinet

Multi-Deck



PRODUCT OVERVIEW

Designed for maximum product exposure and efficient chilled storage, our full height multi deck case is a staple solution for modern main store environments.

The chilled full height remote multi deck cabinet with (5) 24" deep shelves including standard price tag moulding.

Available as: 81.7" x (40.4", 42.3", 79", 79.25", or 121") x 42.2" (H x W x D)



FEATURES

- Temp. Class 3M1 (32F/41F) For Dairy
- Temp. Class 3M0 (32F/39F) For Meat
- R744 Refrigerant
- Danfoss or RDM
- Vertical lighting
- Solid, mirrored end walls
- Plexiglass dividers or intermediate ends available for segmentation
- (5) 20" Shelves Plus, Base
- Price tag moulding, optional Shelf risers
- EC EBM fans
- Electronic controller
- Canopy lighting
- Automatic defrost
- Night-blind
- Multiplexable
- Solenoid valves as standard
- Aerofoil technology available as an ancillary
- RAL exterior specified per customer
- RAL interior specified per customer

DIMENSIONS

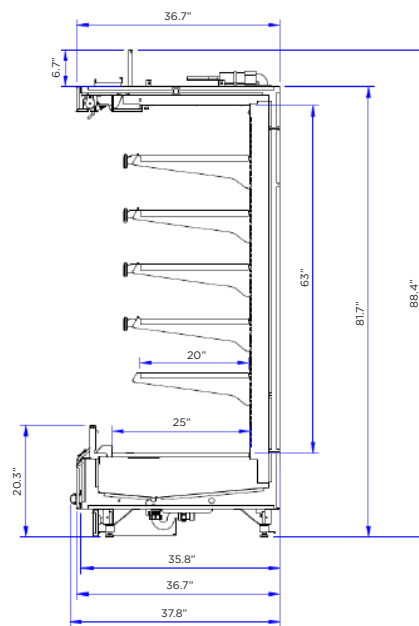

Model	Height	Width (Ex. End)	End Wall Thickness	Depth
IC Cabinet	81.7"	40.4"	1.25" or 2"	36.8"
IC Cabinet	81.7"	42.3	1.25" or 2"	36.8"
IC Cabinet	81.7"	79"	1.25" or 2"	36.8"
IC Cabinet	81.7"	79.25"	1.25" or 2"	36.8"
IC Cabinet	81.7"	121"	1.25" or 2"	36.8"

ID Cabinet

Multi-Deck



PRODUCT OVERVIEW

Introducing our high performance open multideck cabinet, designed to elevate your chilled food presentation while maintaining optimal temperature control and energy efficiency.

Includes (5) 18" deep shelves including price tag moulding as standard.

Available in 4', 6', 8' and 12' lengths.

FEATURES

- Meat / Dairy / Produce - 75F @ 55%RH
- Remote, Air Cooled, and Water Cooled options
- Danfoss or RDM
- Solid shelves
- Vertical lighting
- End walls specified per customer
- (5) 18" Shelves Plus, Base
- Ticket strip and optional Shelf risers
- Shelf strengtheners as standard
- EC EBM fans
- Electronic controller
- Soft close manual night blind
- Canopy lighting
- Automatic defrost
- Multiplexable
- Solenoid valves as standard
- RAL exterior specified per customer
- RAL interior specified per customer
- End user specific colours & finishes available



DIMENSIONS

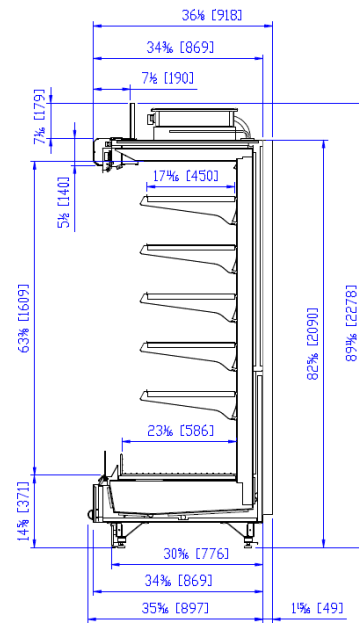

Model	Height	Width (Ex. End)	End Wall Thickness	Depth
ID Cabinet	82.3"	144"	1.25" or 2"	34.2"
ID Cabinet	82.3"	96"	1.25" or 2"	34.2"
ID Cabinet	82.3"	72"	1.25" or 2"	34.2"
ID Cabinet	82.3"	48"	1.25" or 2"	34.2"

IH Cabinet

Multi-Deck



PRODUCT OVERVIEW

Built for demanding retail environments, this full height doored cabinet offers a high-capacity, visually striking solution for chilled product display, combining structural integrity with flexible merchandising.

Includes (5) 20" deep shelves including price tag moulding as standard.

Available in 4', 6', 7', 8', and 12' lengths.



FEATURES

- Meat 3M0 32/39F 75F 55RH / Dairy
- R744 Refrigerant
- Danfoss or RDM
- Solid or Wire shelves
- Vertical Mullion lighting.
- (5) 20" Shelves Plus, Base
- Price tag moulding, optional Shelf risers
- Sliding and hinged available
- End wall specified per customer
- EC EBM fans
- Electronic controller
- Canopy lighting available
- Automatic defrost
- Multiplexable
- Solenoid valves as standard
- RAL exterior specified per customer
- RAL interior specified per customer

DIMENSIONS

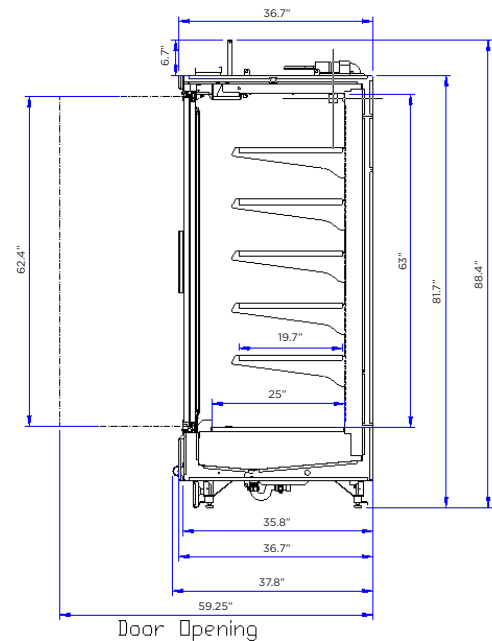

Model	Height	Width (Ex. End)	End Wall Thickness	Depth
IH Cabinet	81.7"	40.4"	1.25" or 2"	36.7"
IH Cabinet	81.7"	84"	1.25" or 2"	36.7"
IH Cabinet	81.7"	42.8"	1.25" or 2"	36.7"
IH Cabinet	81.7"	80.7"	1.25" or 2"	36.7"
IH Cabinet	81.7"	121"	1.25" or 2"	36.7"



CARTER

LSICORP.COM/CARTER
800.436.7800

