

IC Cabinet

Multi-Deck



PRODUCT OVERVIEW

Designed for maximum product exposure and efficient chilled storage, our full height multi deck case is a staple solution for modern main store environments.

The chilled full height remote multi deck cabinet with (5) 24" deep shelves including standard price tag moulding.

Available as: 81.7" x (40.4", 42.3", 79", 79.25", or 121") x 42.2" (H x W x D)



FEATURES

- Temp. Class 3M1 (32F/41F) For Dairy
- Temp. Class 3M0 (32F/39F) For Meat
- R744 Refrigerant
- Danfoss or RDM
- Vertical lighting
- Solid, mirrored end walls
- Plexiglass dividers or intermediate ends available for segmentation
- (5) 20" Shelves Plus, Base
- Price tag moulding, optional Shelf risers
- EC EBM fans
- Electronic controller
- Canopy lighting
- Automatic defrost
- Night-blind
- Multiplexable
- Solenoid valves as standard
- Aerofoil technology available as an ancillary
- RAL exterior specified per customer
- RAL interior specified per customer

DIMENSIONS

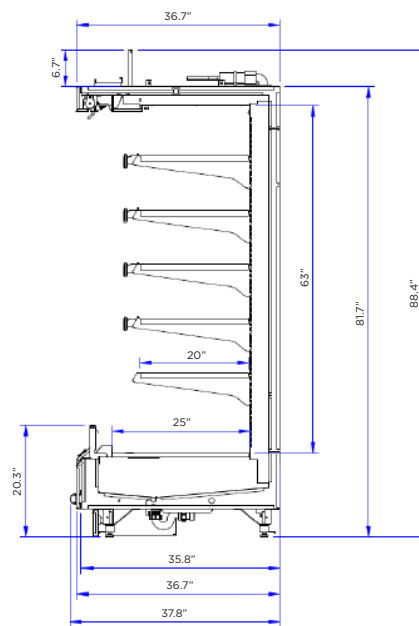

Model	Height	Width (Ex. End)	End Wall Thickness	Depth
IC Cabinet	81.7"	40.4"	1.25" or 2"	36.8"
IC Cabinet	81.7"	42.3"	1.25" or 2"	36.8"
IC Cabinet	81.7"	79"	1.25" or 2"	36.8"
IC Cabinet	81.7"	79.25"	1.25" or 2"	36.8"
IC Cabinet	81.7"	121"	1.25" or 2"	36.8"