

# IB Cabinet

Multi-Deck



## PRODUCT OVERVIEW

The IB is our deepest open multi deck case designed for large format stores. It is high performance, high efficiency commercial refrigeration solution engineered for maximum merchandise capacity and product visibility.

Designed for flexibility and sustainability, the IB is available configured for use with HFC or CO2 direct expansion rack system, or as an R290 water cooled integral solution where racks are not applicable.

Available in 4', 6', 8', 10' and 12' lengths.

## FEATURES

- Temperature range 32F/39F
- R744: Remote
- HFC: Remote
- R290: Self-contained
- Solid, mirrored end walls
- Plexiglass dividers or intermediate ends available for segmentation
- 24" shelf depth
- Various control strategies available
- Canopy and shelf lighting
- Night Blind
- Range of all real colors available
- Aerofoil technology available as an ancillary



## DIMENSIONS

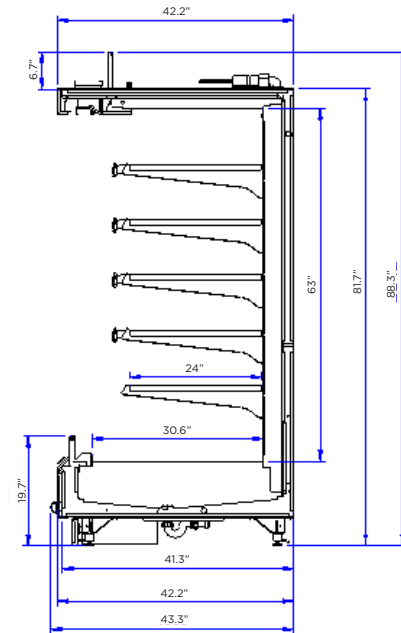

Model	Height	Width (Ex. End)	End Wall Thickness	Depth
IB Cabinet	81.7"	147.6"	1.25" or 2"	42.2"
IB Cabinet	81.7"	98.4"	1.25" or 2"	42.2"
IB Cabinet	81.7"	84.1"	1.25" or 2"	42.2"
IB Cabinet	81.7"	73.8"	1.25" or 2"	42.2"
IB Cabinet	81.7"	49.2"	1.25" or 2"	42.2"