



## **SERVICE MANUAL**

**FOR**

**UNDERCOUNTER REFRIGERATORS  
FREEZERS**

**PREPERATION TABLES/SANDWICH UNITS  
GRAB N GO UNITS**

Please fill in the following information for your NEW unit, carefully read the instructions in this manual and file it for future reference.

MODEL NO. \_\_\_\_\_

SERIAL NO. \_\_\_\_\_

PURCHASED FROM \_\_\_\_\_

INSTALL DATE \_\_\_\_\_



**1-800-222-0450**

**EMI Industries LLC. – New Jersey Division**

A Division of EMI Industries, Inc.  
301 Division St., Boonton, N.J. 07005  
P 973-423-0226  
[www.emiindustries.com](http://www.emiindustries.com)

# Table of Contents

Warning and Cautions Before Servicing.....	page 3
General Information and Important Facts.....	page 4
Installation and Location.....	page 5
Ventilation.....	page 5
Leveling Unit.....	page 5
Optional Casters.....	page 6
Cabinet Doors.....	page 7
Start Up Procedure.....	page 8
Electrical Connections.....	page 9
Remote Applications.....	page 9
Operation.....	page 10
Refrigeration System and Adjustment.....	page 10
Freezer System and Adjustment.....	page 11
Cold Rail/Mechanical Cold Pan.....	page 13
Grab N Go.....	page 14
Evaporator Assembly.....	page 15
Multiple Evaporators.....	page 15
Interior Accessories.....	page 16
Shelving Installation.....	page 16
Safety Precautions.....	page 17
Maintenance.....	page 17
Periodic Cleaning Procedure.....	page 17
Precautions.....	page 18
Alternate Material Care.....	page 18
General Preventative Maintenance.....	page 19
Parts and Service.....	page 19
Trouble Shooting and Service Guide.....	page 20
Product Limited Warranty.....	page 23
Appendix.....	page 24

## Wiring Schematics:

Wiring Harness.....	page 24
Self Contained Refrigerator .....	page 25
Self Contained Refrigerator w/ electronic motor.....	page 26
Self Contained Refrigerator w/ raised rail-cold pan.....	page 27
Self Contained Refrigerator w/ raised rail-cold pan w/electronic motor.....	page 28
Self Contained Refrigerator w/ low pressure switch....	page 29
Self Contained Refrigerator w/ low pressure switch w/electronic motor.....	page 30
Self Contained Grab N Go.....	page 31
Self Contained Freezer.....	page 32
Self Contained Refrigerator w/ frost top.....	page 33
Remote Refrigerator.....	page 34
Remote Refrigerator w/raised rail-cold pan.....	page 35
Remote Freezer.....	page 36
Remote Freezer w/raised rail-cold pan.....	page 37

## Refrigeration Schematics:

Self Contained Refrigerator.....	page 38
Self Contained Freezer.....	page 38
Self Contained Refrigerator w/rail-cold pan.....	page 39
Self Contained Grab N Go.....	page 39
Remote Refrigerator.....	page 40
Remote Freezer.....	page 40
Remote Refrigerator w/rail-cold pan.....	page 41

## Warnings and Cautions Before Servicing

Misuse of the equipment and failure to comply with the operating and servicing instructions supplied by EMI Industries can be dangerous.

Most of the equipment described in this manual operates at 115 Volt. There are some products that require a 230 Volt electrical supply. An unprotected experience with 230 volts of electricity can be extremely dangerous. Before working on electrical circuits, make sure that the power cord has been disconnected.

All refrigerant gas charges specified on the serial nameplate of the unit must be strictly adhered to and accurately measured, preferably by weighing. EMI Industries will accept no responsibility for the consequences of using inaccurately measured charges.

Equipment maintenance, replacement of components and internal adjustments must **ONLY** be carried out by qualified and experienced refrigeration personnel.

### **Safety at Work:**

Service personnel are responsible for familiarizing themselves with the equipment owner's safety policy and regulations.

### **Disclaimer Notice:**

EMI Industries reserves the right to change information in this document without notice. Updates to information in this document reflect our commitment to continuing product development and improvement.

## General Information And Important Facts

**This manual has been compiled to aid in the installation, operation, and maintenance of your new equipment. Please take the time to read all of the material in order to become more familiar with your equipment and its operation.**

- Self contained models are self defrosting and use automatic defrost condensate water evaporating systems. All self contained mechanical cold pans must be discharged to an indirect drain.
- All models require adequate time to reach normal operating temperatures before placing any food inside the cabinet or pans if provided ( see "Operation Section" for information on typical pulldown times and cabinet temperatures).
- On all open top refrigerators it is advised to keep the top lid closed when the unit is not in use. Never operate open top models without pans in place.
- Before product is shipped from the factory, they are performance tested for a minimum of 12 hours. A final leak check, noise and vibration check, and visual examination is conducted by a certified internal audit team to guarantee a quality product.

The carrier signs to this effect when he accepts the product for shipping.

***Important Note:*** To insure maximum compliance with respect to safety and sanitation, units are listed under re-examination service with the following agencies:

- U.L. (Underwriter's Laboratories)
- E.T.L. (Electrical Testing Laboratories)
- N.S.F. (National Sanitation Foundation)

## Installation and Location

### Ventilation:

The final location of the unit is very important for efficient, trouble-free operation. Environments which provide adequate quantities of clean, dry air circulation are preferred. On models with open top refrigeration, avoid locations near direct sunlight where temperatures can be in excess of 100° F.

***Important Note:*** The condensing unit, located behind the louvered door panel requires an adequate air supply. Restricting the louvers reduces the flow of air creating an undesired heat load on the compressor causing an adverse operating condition.

### Leveling Unit:

Your unit is equipped with adjustable stainless steel heavy duty legs to help level your model. Each leg is screwed to a mounting plate attached to the bottom of the unit. The bullet – type leveling foot shown in Figure 1 can be turned by hand or with a wrench to level the unit.

***Important Note:*** During installation, make sure each leg is tightened extremely well. Loose fitting legs could cause the unit to sway when opening and closing the doors.

If the unit is not leveled properly, it will not operate at maximum efficient conditions.

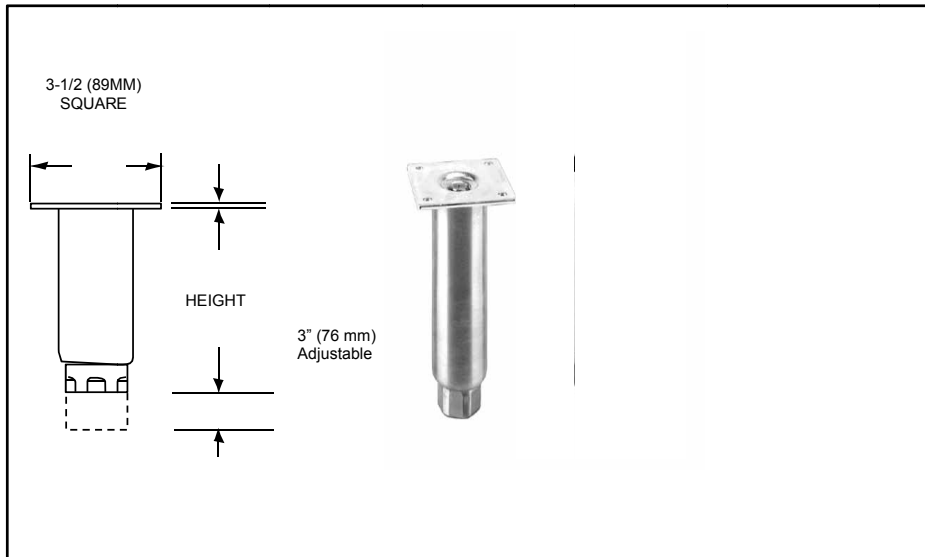
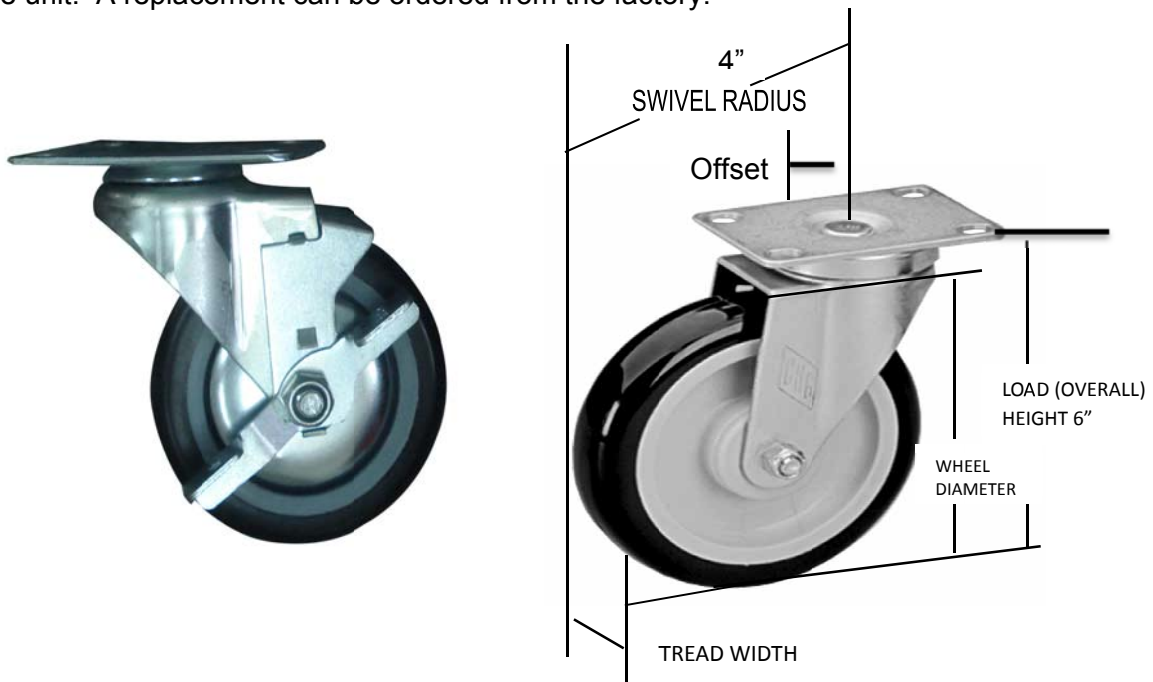

**Figure 1**

**Optional Casters:**

If you ordered your unit with optional casters, it will be shipped to you with the casters factory installed. Each caster is a full swivel type. At least (2) of the casters provided have brakes.

Each caster can be replaced if necessary by removing the (4) bolts holding the plate to the unit. A replacement can be ordered from the factory.



**Figure 2**

### Cabinet doors:

Refrigerator and freezer models come with self-closing doors and removable gaskets which feature a snap-in design for easy replacement. These doors have been developed for easy removal from the cabinet allowing them to be placed on a convenient work surface for gasket replacement.

1. Grooved extruded plastic strips with mitered corners are installed into foamed outer stainless steel cabinet doors.
2. V-shaped section located on bottom side of gasket and extend around entire perimeter is aligned with grooves in strips.
3. The gasket is then pressed down against the grooved strip providing a very reliable snap fit.
4. To remove gasket, simply pull away from door to separate V-shaped section of gasket from grooves in extruded strips.



Figure 3

All doors have been aligned at the factory prior to shipping. During shipping, vibration may cause doors to shift. If the doors require realignment, proceed as follows:

1. Swing door to open position and loosen, but **Do Not Remove** the screws holding the hinge to the body.
2. Relocate the door to its required position by hand or by tapping lightly on the door edge with a hammer and a block of wood.
3. Tighten all screws securely.



To remove the hinge assembly from the door, remove the door from the unit as explained above.

1. Remove cover plate
2. Remove all screws holding hinge block to face of unit.
3. Remove all screws that hold hinge to the door edge.
4. Install new hinge assembly to unit and door.
5. Return door to unit and realign by following procedure described above.

## Startup Procedure

Before starting your unit and placing food inside, the interior of the cabinet should be carefully cleaned. Follow the sequence below:

1. Using a sponge, wash with mild warm water solution.
2. Clean with a baking soda solution (3 tbsp. baking soda to 1 qt. of warm water).
3. Rinse with clear water.
4. Dry with soft cloth.

***Important Note:*** Never use harsh detergents, cleaners, scouring powders or chemicals when cleaning your model. Failure to dry interior surfaces after cleaning may result in streaking or staining of the metal.

## Electrical Connections:

To insure proper operation, your new refrigerator or freezer must be connected to an individual circuit that can supply the full voltage as stated on the cabinet serial nameplate. For correct voltage, phase/freq. and ampacity check the data on nameplate.

Certify that this information exactly matches the electrical characteristics at the installation location. For reference, a copy of each electrical wiring diagram is located at the rear of this manual.

**1. 115 Volt, 60 Hz, 1 Phase Model.** These models are provided with a U.L. approved power cord and polarized NEMA plug (5-15P or 5-20P style).

**2. 230 Volt, 60 Hz, 1 Phase Model.** These models are provided with a power cord and plug or an electrical "junction box" located in the condensing unit compartment.

***Important Note:*** The condensing unit supplied with all self-contained models is designed to operate with a voltage fluctuation of  $\pm 10\%$  of the voltage indicated on the cabinet serial nameplate. Full voltage of the correct service, on an individual line not affected by the operation of other electrical appliances, must be available to the condensing unit at all times. Burnout of the compressor can occur due to exceeding high or low voltage limits.

After your model has been installed, leveled, cleaned, and electrically connected in accordance with this manual the system should run smoothly in accordance with generally accepted commercial standards.

If any unusual noises are heard, turn the unit off immediately and check for any obstructions of the condenser or evaporator fans. Fan motors, fan blades or fan housings can be jarred out of position through rough handling in transit or during installation.

## Remote Applications:

All models are also available for purchase as remote units. These units are provided with the following features:

- Expansion valve within the evaporator housing.
- Liquid and suction lines brazed closed.
- Refrigeration system supplied with nitrogen holding charge.

***Important Note:*** Installation of the refrigeration accessories, condensing unit, and electrical hook-up should be performed by qualified refrigeration personnel from a competent refrigeration company only. The wiring must conform to all local electrical codes.

## Operation

Both refrigerators and freezers require an appropriate amount of time to reach normal operating temperatures before food should be placed into the cabinet or pans (if provided). Pans should be installed with top lid closed during initial pulldown.

Model	Pull down time	Factory design cabinet temperature range
Refrigerators	1 hour	36° to 40° F (2.2° to 4.4°C)

Table 1

### Refrigeration System and Adjustment:

All self-contained refrigerators are designed and factory set to maintain an average cabinet temperature of 38°F. If an adjustment is necessary to maintain the temperature range shown in Table 1, turn the thermostat knob clockwise for a colder cabinet temperature or counterclockwise for a warmer cabinet temperature. See Figure 4.

The temperature control is accessible inside of the cabinet product compartment. It is typically located on one of the side walls of the evaporator housing. The sensing portion of the capillary is inserted into the evaporator approximately 3" from the end of the coil.

Control Specifications: Model No. Ranco A12-701  
Mid-Range Cut Out (Setting # 4): 23.5°F / Cut In: 41°F  
Capillary Length: 84"

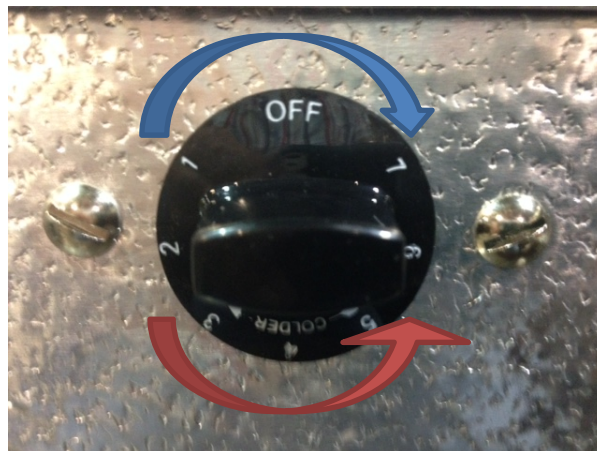

Figure 4

**Important Note:** All refrigerators are designed with an automatic “off-cycle” defrost system. Defrosting occurs automatically when the compressor is not operating during an off-cycle. Do not set the thermostat too cold where the cabinet temperature can fall below 34° F.

Model	Pull down time	Factory design cabinet temperature range
Freezers	2 hours	0° to 10° F (-17.8° to -12.2°C)

Table 2

**Freezer System and Adjustment:**

All self-contained freezers are designed and factory set to maintain an average cabinet temperature of 5° F. If an adjustment is necessary to maintain the temperature range shown in Table 2, turn the thermostat knob clockwise for a colder cabinet temperature or counterclockwise for a warmer cabinet temperature. See Figure 5.



Figure 5

All freezers are designed for the purpose of holding pre-frozen food and freezing small quantities of fresh food. They are not to be used as fast or blast freezers. **Do not** attempt to freeze bulk quantities of fresh foods.

The temperature control is accessible inside the cabinet compartment on the evaporator blower housing.

The capillary sensor is rolled in a 3” loop and taped to bottom cover of the blower housing next to fan motor bracket with aluminum tape. The capillary end does not get inserted into the evaporator coil

Control Specifications: Model No. Ranco A30-2211  
 Mid-Range Cut Out (Setting # 4): 16°F / Cut In: 40°F  
 Capillary Length: 84”

**Important Note:** Further adjustments outside of the factory design temperature range must be made by a qualified refrigeration technician only.

Each freezer is provided with a defrost clock shown in Figure 6. It is located in front of the condensing unit compartment.

After the initial startup, the clock will need to be synchronized to the correct time of day. Rotate the small center knob counterclockwise until the correct time shown on the larger outer dial aligns with the “time” pointer.

1. The defrost clock has been factory preset for (3) defrost periods per day at (8) hour intervals: 8:00 AM, 4:00 PM, and 12:00 AM. The three screws in Figure 6 show the start of each defrost cycles. A 4<sup>th</sup> screw is provided if an additional defrost cycle is needed.
2. The duration of each defrost “off time” cycle has been factory preset to 20 minutes. This is indicated by the position of the copper pointer on the smaller inner dial.
3. To change time between defrost periods, transfer screws shown in Figure 6 to any available threaded hole. Holes are located at two hour intervals.
4. To change duration of each defrost “off time”, depress copper pointer on smaller inner dial and move to new time location.

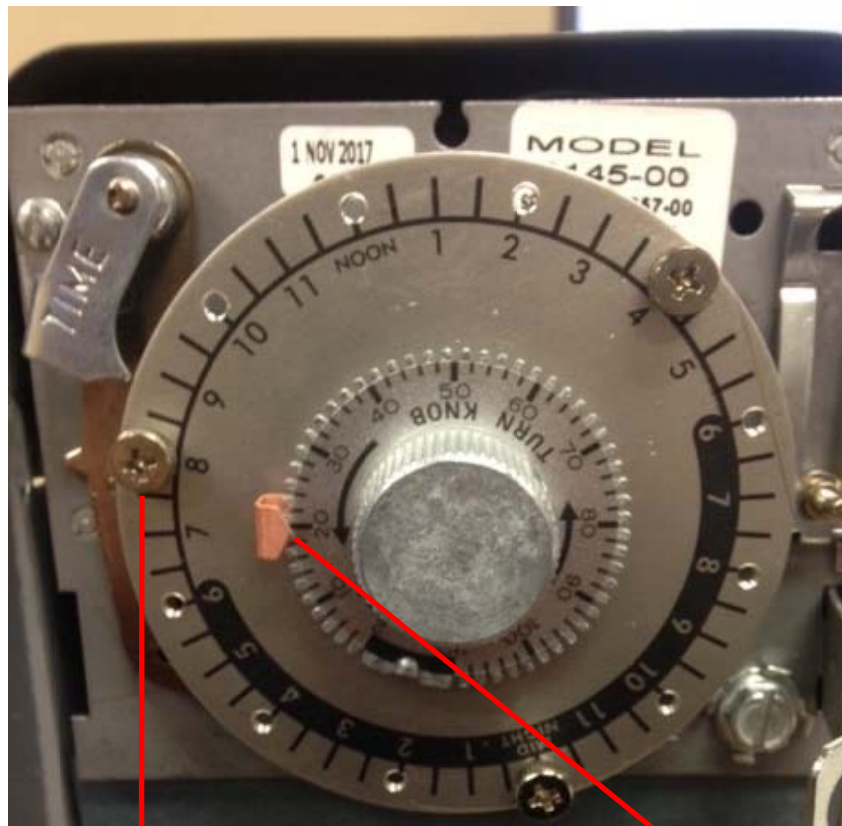

**Cycle “start time”  
screws**

Figure 6

**Cycle “off time”  
indicator**

## Cold Rail/Mechanical Cold Pan:

If the unit has a cold rail, a switch is provided to turn it on or off. Typically the switch, shown in Figure 7, is mounted on the front apron above the condensing unit compartment or inside the compartment housing.

The rail temperature can be changed to a colder or warmer setting by adjusting the temperature controller shown in Figure 8. The temperature adjustment screw is located on the top right hand side of the controller. Turn screw clockwise for a colder setting and counterclockwise for a warmer setting. The differential screw is located on top left hand side. Turn screw clockwise for lower setting or counterclockwise for higher differential setting.

Control Specifications: Model No. Ranco 010-1416  
Capillary Length: 72" (Cross Ambient )

Factory settings for this controller are: (see Figure 9)

Cut In: 15°F  
Cut Out: 7.5° F  
Differential: 7.5° F

**Note:** The defrost time on the cold rail is controlled manually by turning off the rail switch until the walls are frost free.

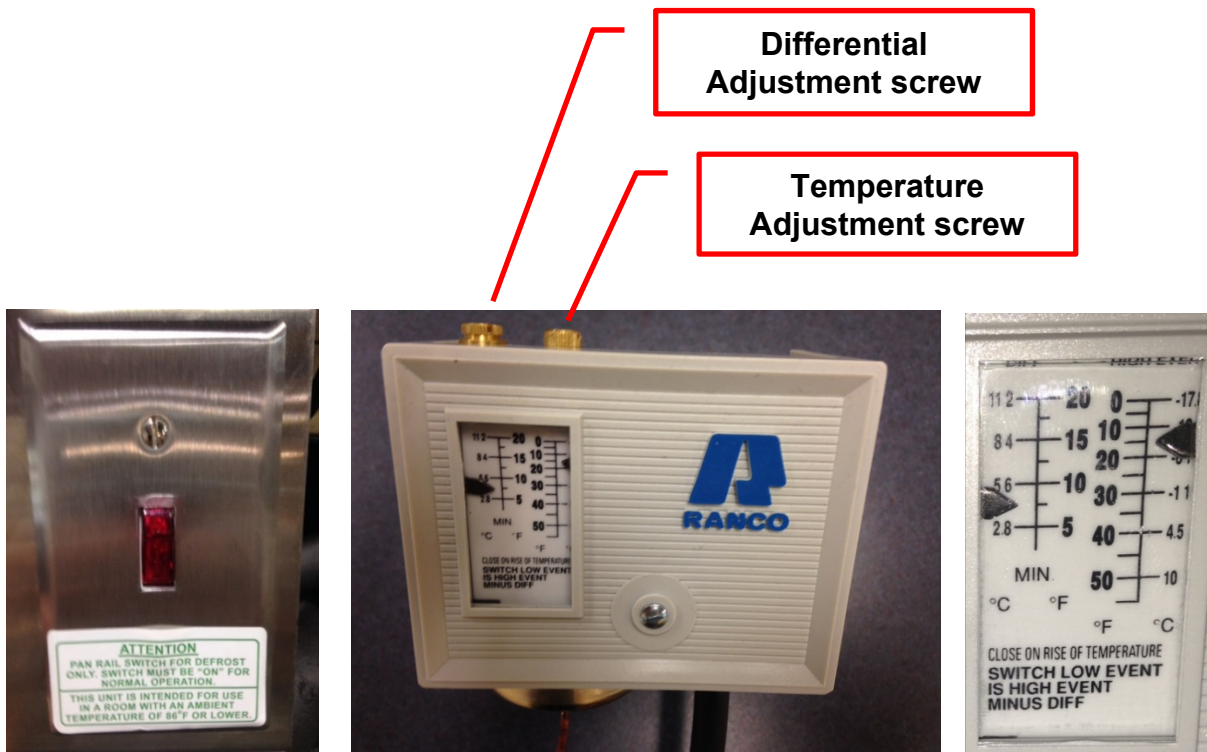

Figure 7

Figure 8

Figure 9



## Grab “N” Go:

The Grab ‘N’ Go unit has a switch similar to the cold rail to turn the compressor on or off. The switch, shown in Figure 7, is mounted on the front apron above the condensing unit compartment or inside the compartment housing.

The Grab ‘N’ Go temperature can be changed to a colder or warmer setting by adjusting the temperature controller shown in Figure 8. The adjustment screw is located on the top right hand side of the controller. Turn screw clockwise for a colder setting and counterclockwise for a warmer setting.

Each Grab ‘N’ Go is provided with a defrost clock shown in Figures 10 and 11. It is located in front of the condensing unit compartment.

After the initial startup, the clock will need to be synchronized to the correct time of day. Pull center dial out and rotate the dial until the center pointer is aligned with the correct time. Then push dial in until it seats.



Figure 10



Figure 11

The defrost clock has been factory preset for (1) defrost period per day at 12 A.M. for 1 hour. This is the minimum defrost period. If a longer time is desired, loosen the screw on the “green” pointer and move it counterclockwise around the dial to a new time for the defrost period to end. (Compressor restarts).

### Evaporator Assembly:

All under counter refrigerators, freezers, and preparation tables have an easily accessible, easily serviceable, forced-air evaporator assembly.

**Important Note:** Evaporator air flow fan must be kept free from any obstruction.

### Multiple Evaporators:

Some units are supplied with more than one evaporator blower and/or cold pan. These designs will have a low pressure switch located next to the compressor. When the temperature of each evaporator/cold pan is satisfied, the temperature controller will close a solenoid valve stopping refrigerant flow into the evaporator/cold pan. If all solenoid valves are closed, the compressor will pump down until the low pressure switch turns off the compressor.

Refrigeration schematics with low pressure switch are shown in the Appendix.

Low Pressure Switch Specifications: Model No. Ranco 010-1483  
Pressure Connection: SAE Flare Nut  
Capillary Length: 36"

Factory settings for this controller are: (see Figure 12)

Cut In: 36 psi  
Cut Out: 14 psi  
Differential: 22 psi



Figure 12



## Interior Accessories

The standard interior accessory package that is supplied from the factory with your unit consists of standard pilaster strips and pilaster clips. (4) clips per shelf and (1) epoxy coated shelf per section.

In addition to the standard epoxy coated shelf, custom perforated stainless steel shelving can also be provided.

### Shelving Installation:

Pilaster strips which support the shelving are secured to the cabinet walls with thumb screws which allow the strips to be readily removed for cleaning without the use of tools. Shelf clips are easily installed by inserting them into the pilasters at the desired shelf location and shelf installation is as simple as placing the shelf on the clips. See Figure 13.

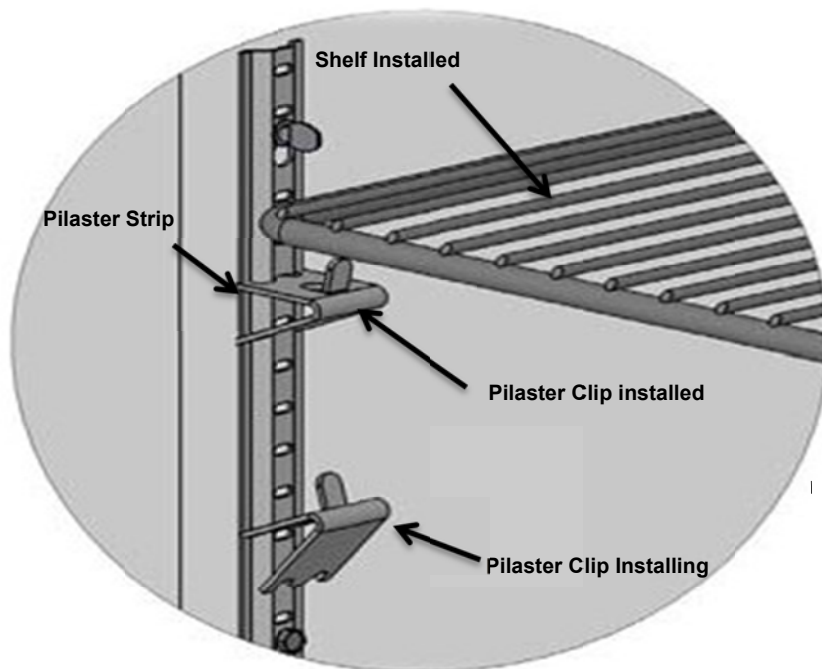

Figure 13

## Safety Precautions

**The following safety precautions should be followed when operating any appliances:**

1. Always disconnect the power cord to the unit before attempting to replace light bulbs or clean equipment to avoid electrical shock.
2. **Never** unplug the unit by pulling on the power cord. Always grip the plug firmly and pull straight out from the receptacle to prevent damaging the power cord.
3. Disconnect the power cord when the appliance is not in use.
4. **Do not** attempt to service this unit yourself as removing any covers may cause exposure to dangerous voltage.
5. Always route the power cord so that it is not likely to be walked on or pinched by other appliances. **Never** use extension cords.
6. **Do not** overload outlets with more than one appliance. This can result in fire or electrical shock.
7. **Do not** plug the unit into an electrical outlet controlled by a wall switch to prevent the refrigerator/freezer from being turned off accidentally.
8. Your model is equipped with a grounded and polarized plug. **Do not** defeat the purpose of this plug by removing the ground post or using a non-polarized adapter without properly grounding the outlet.
9. When a replacement part is required, always insist on factory authorized parts only.

## Maintenance

### **Periodic Cleaning Procedure:**

It is best to clean your refrigerator or freezer when the product load is at its lowest level inside your cabinet. To clean the interior or exterior cabinet surfaces, the following procedure is recommended:

1. Disconnect your model from its power supply and remove all food products from inside the cabinet.
2. Open all doors and allow the cabinet to reach room temperature. Remove all accessories (shelves, racks, pilasters, clips, etc.). Using a sponge, wash the interior, exterior, and accessories with a baking soda and warm water solution. Rinse thoroughly with clear water and dry with a soft clean cloth.
3. Return all accessories to their respective positions and reconnect electric power supply to the unit.

4. Energize unit and allow appropriate amount of time to reach normal operating temperature before returning food product to cabinet (see “operation Section” for pulldown times and cabinet temperatures).

***Important Note:*** Failure to dry all surfaces completely may cause water stains or streaking on stainless steel finish.

**Precautions:**

1. Never use harsh detergents, cleaners, scouring powders, or chemicals when cleaning your unit.
2. Strong bleaches tend to corrode many materials and should never come in contact with stainless steel.
3. Tincture of iodine, or iron should not come in contact with stainless steel. These solutions, which cause stainless steel to discolor, should be rinsed off immediately if contact occurs.
4. Gritty, hard abrasives will mar the finish of stainless steel and are not recommended.

**Alternate Material Care:**

Your refrigerator or freezer may be constructed with materials other than stainless steel. Alternate materials and their cleaning instructions are shown below:

**• Wood/Laminate**

**Cleaning Instructions:**

Wipe dirty surface with a clean cloth dampened with a mild soap/detergent and water solution (most household dishwashing detergents are acceptable).

**Warning:**

Excessive prolonged exposure to direct sunlight, high temperatures and high humidity should be avoided as they can damage the finish. Avoid ammonia based and/or silicone-containing cleaners as they can cause damage or discoloration to the finish over time.

**• Solid Surface**

**Cleaning Instructions:**

Routinely clean surfaces with a clean cloth dampened with a mild soap/detergent and water solution (most household dishwashing detergents are acceptable).

If you prefer, use an ammonia based cleaner, such as Windex or 409, and wipe dry.

**Warning:**

Do not expose surface to harsh chemicals, such as paint removers, turpentine, nail polish removers or stove and drain cleansers. If contact occurs, immediately wash surface off with water.

## **General Preventative Maintenance:**

**Performance of the air cooled condenser coil located inside of the condensing unit compartment of your new unit depends primarily on the amount of air passing through the condenser fins.**

1. Your refrigerator or freezer will run more efficiently, consume less energy, and provide maximum trouble free service throughout its lifetime if the condenser is kept clean and an adequate supply of clean air is provided at all times. Once a month, inspect the condenser coil and check for blockage. If the condenser coil is dirty or blocked, disconnect the power supply to your unit and remove the dirt from the condenser fins. Using a vacuum cleaner with a brush attachment may help in the cleaning process. After cleaning, restore electrical service to your unit.
2. Each unit has a drain tube located inside the cabinet that removes the condensation from the evaporator coil housing and routes it to an external condensate evaporator pan. The drain tube can become loose or disconnected during normal use. If you notice water accumulation on the inside of the unit, be sure the drain tube is connected to the evaporator drain pan. If water is collecting underneath the unit, make sure the end of the drain tube is in the condensate evaporator pan. The leveling of the unit is important as the units are designed to drain properly when level. Be sure all drain lines are free of obstructions.
3. Over time and with heavy-use doors, the hinges may become loose. If this happens, tighten the screws that mount the hinge brackets to the frame of the unit. Loose or sagging doors can cause the hinges to pull out of the frame, which may damage both the doors and the hinges. In some cases this may require qualified service agents or maintenance personnel to perform repairs.
4. Wipe casters with a damp cloth monthly to prevent corrosion.

## **Parts and Service:**

When contacting the factory for authentic replacement parts provide the following:

1. Cabinet model
2. Serial number (located on the serial nameplate inside cabinet wall)
3. Date of purchase

# Trouble Shooting and Service Guide

**Use the following as a guide to determine possible cause and corrective action procedure for customer issues.**

SYMPTOM	POSSIBLE CAUSE	PROCEDURE
Unit doesn't run	<ol style="list-style-type: none"> <li>1. Improper wiring or loose connections.</li> <li>2. Temperature controller faulty.</li> <li>3. Condenser fan motor faulty.</li> <li>4. Compressor overload protector faulty.</li> <li>5. Compressor relay faulty.</li> <li>6. Compressor faulty</li> </ol>	<ol style="list-style-type: none"> <li>1. Compare wiring to diagram and check for loose or broken connections.</li> <li>2. Replace temperature controller.</li> <li>3. Service and replace motor if necessary.</li> <li>4. See "Compressor Service Issues". Replace if necessary..</li> <li>5. See "Compressor Service Issues". Replace if necessary.</li> <li>6. See "Compressor Service Issues". Replace if necessary.</li> </ol>
Unit short cycles	<ol style="list-style-type: none"> <li>1. Overload repeatedly tripping due to extreme high side pressure</li> <li>2. Refrigerant system overcharged or air in the system.</li> <li>3. Low pressure control valve cut-out due to valve leak, or system undercharge.</li> <li>4. Solenoid not seating.</li> <li>5. Compressor faulty.</li> </ol>	<ol style="list-style-type: none"> <li>1. Insufficient airflow due to dirty condenser coil or faulty condenser fan motor. Clean coil or replace fan motor.</li> <li>2. Evacuate and recharge with correct charge.</li> <li>3. Replace valve, evacuate system and recharge with correct charge.</li> <li>4. Replace solenoid.</li> <li>5. See "Compressor Service Issues". Replace if necessary.</li> </ol>
Unit runs continuously or long periods of time.	<ol style="list-style-type: none"> <li>1. Low refrigerant charge due to leak in refrigeration system.</li> <li>2. Temperature control contacts stuck in closed position.</li> <li>3. Restriction in refrigeration system due to clogged filter drier.</li> <li>4. Expansion valve restriction or improper setting.</li> </ol>	<ol style="list-style-type: none"> <li>1. Fix leak, evacuate and recharge.</li> <li>2. Clean contacts or replace temperature controller.</li> <li>3. Replace filter dryer, evacuate and recharge unit.</li> <li>4. Replace expansion valve or set to proper superheat.</li> </ol>
Product zone temperature too high	<ol style="list-style-type: none"> <li>1. Evaporator coil iced over.</li> <li>2. Cabinet thermometer not reading properly.</li> </ol>	<ol style="list-style-type: none"> <li>1. Turn unit off and allow coil to defrost. Make sure control is not set too cold. Check condition of door gaskets.</li> <li>2. Check thermometer and recalibrate or replace if necessary.</li> </ol>
Product zone temperature too cold	<ol style="list-style-type: none"> <li>1. Temperature controller faulty.</li> </ol>	<ol style="list-style-type: none"> <li>1. Replace temperature controller.</li> </ol>

Suction line frosted or sweating	<ol style="list-style-type: none"> <li>1. Overcharge of refrigerant.</li> <li>2. Evaporator fan not running.</li> <li>3. Expansion valve stuck open.</li> <li>4. Expansion valve superheat too low.</li> </ol>	<ol style="list-style-type: none"> <li>1. Evacuate refrigeration system and recharge.</li> <li>2. Determine cause and correct or replace fan.</li> <li>3. Clean valve or replace if necessary. Evacuate and recharge.</li> <li>4. Adjust superheat to required setting.</li> </ol>
Liquid line frosted, cold, or sweating.	<ol style="list-style-type: none"> <li>1. Restriction in filter dryer.</li> <li>2. Liquid line service valve partially closed.</li> </ol>	<ol style="list-style-type: none"> <li>1. Replace drier, evacuate, and recharge.</li> <li>2. Open valve fully or replace if necessary.</li> </ol>
Rail not cold enough, base temperature is okay	<ol style="list-style-type: none"> <li>1. Temperature control faulty.</li> <li>2. Solenoid valve not energized.</li> <li>3. Expansion valve restriction or improper setting.</li> </ol>	<ol style="list-style-type: none"> <li>1. Replace temperature controller.</li> <li>2. Check temperature controller for power to solenoid.</li> <li>3. Replace expansion valve or set to proper superheat.</li> </ol>
Base not cold enough, rail temperature is okay.	<ol style="list-style-type: none"> <li>1. Temperature control faulty.</li> <li>2. Faulty evaporator fan motors.</li> <li>3. Solenoid valve not energized.</li> <li>4. Expansion valve restriction or improper setting.</li> </ol>	<ol style="list-style-type: none"> <li>1. Replace temperature controller.</li> <li>2. Determine cause and replace fan motors if necessary.</li> <li>3. Check temperature controller for power to solenoid.</li> <li>4. Replace expansion valve or set to proper superheat.</li> </ol>
Unit noisy	<ol style="list-style-type: none"> <li>1. Compressor mountings loose or hardened.</li> <li>2. Condenser fan damaged or hitting shroud.</li> <li>3. Evaporator fan(s) damaged or hitting shroud.</li> </ol>	<ol style="list-style-type: none"> <li>1. Tighten or replace compressor mountings.</li> <li>2. Inspect condenser fan and clear any obstruction.</li> <li>3. Inspect evaporator fan(s) and clear any obstructions.</li> </ol>
Water leak inside unit.	<ol style="list-style-type: none"> <li>1. Defective evaporator drain pan.</li> </ol>	<ol style="list-style-type: none"> <li>1. Replace pan.</li> </ol>

## Compressor Related Service Issues

SYMPTOM	POSSIBLE CAUSE	PROCEDURE
<p>Condensing unit will not start. Hums but trips on overload protector.</p>	<ol style="list-style-type: none"> <li>1. Improperly wired.</li> <li>2. Low voltage to unit.</li> <li>3. Start capacitor defective.</li> <li>4. Relay defective.</li> <li>5. Compressor motor has a shorted or open winding.</li> <li>6. Internal mechanical issues inside compressor.</li> </ol>	<ol style="list-style-type: none"> <li>1. Compare wiring to diagram and check for loose or broken connections.</li> <li>2. Determine cause and correct.</li> <li>3. See "Start Capacitor Issues" below. Replace if necessary.</li> <li>4. See "Relay Issues" below. Replace if necessary.</li> <li>5. Replace compressor.</li> <li>6. Replace compressor.</li> </ol>
<p>Condensing unit starts and runs, but short cycles on overload protector.</p>	<ol style="list-style-type: none"> <li>1. Overload protector defective.</li> <li>2. Run capacitor defective.</li> <li>3. Excessive discharge pressure.</li> <li>4. Insufficient air supply.</li> </ol>	<ol style="list-style-type: none"> <li>1. Replace overload.</li> <li>2. See "Run Capacitor Issues" below. Replace if necessary.</li> <li>3. Check restrictions in refrigeration system from compressor to condenser coil.</li> <li>4. Check airflow path to condenser inlet. Clear any obstructions</li> </ol>
<p>Start capacitor open, shorted, or out of specification</p>	<ol style="list-style-type: none"> <li>1. Relay contacts pitted, sticking, or not opening properly.</li> <li>2. Prolonged starting cycle due to:               <ol style="list-style-type: none"> <li>a. low voltage to unit</li> <li>b. starting load too high</li> </ol> </li> <li>3. Low capacitance</li> </ol>	<ol style="list-style-type: none"> <li>1. Clean contacts or replace relay. Replace Start capacitor.</li> <li>2. Replace start capacitor after:               <ol style="list-style-type: none"> <li>a. determine cause for low voltage and correct.</li> <li>b. evacuate and recharge</li> </ol> </li> <li>3. Measure capacitance and replace if out of specification.</li> </ol>
<p>Run capacitor open, shorted, or out of specification</p>	<ol style="list-style-type: none"> <li>1. Low capacitance</li> <li>2. Excessive high side voltage (exceeds 110% of rated maximum).</li> </ol>	<ol style="list-style-type: none"> <li>1. Measure capacitance and replace if out of specification.</li> <li>2. Determine cause and correct.</li> </ol>
<p>Relay defective</p>	<ol style="list-style-type: none"> <li>1. Contacts pitted or sticking due to voltage exceeding 110% of maximum or less than 90% of minimum voltage.</li> <li>2. Loose or vibrating mounting position.</li> <li>3. Loose wiring on relay.</li> </ol>	<ol style="list-style-type: none"> <li>1. Determine cause and correct voltage issue. Clean or replace relay if necessary.</li> <li>2. Secure to a rigid mounting position.</li> <li>3. Tighten all wiring screws.</li> </ol>

## Product Limited Warranty



### PRODUCT WARRANTY

EMI Industries guarantees its products against defect in workmanship and material for one year from date of purchase.

This warranty does not apply to damages, which may result from neglect, accidental or unauthorized damage, normal wear and tear, misuse of product, unauthorized repair, exposure to extremes in temperature and humidity, and alteration or abuse of product.

---

*Alan Harvill, President*

**This warranty is exclusive and in lieu of all other warranties expressed or implied, including any warranty of merchantability and fitness for a particular purpose.**

**EMI Industries does hereby exclude and shall not be liable to purchaser for any consequential or incidental damages.**

**EMI shall not be responsible for economic loss, profit loss, including without limitation, losses or damages arising from food or product spoilage claims, whether or not, they were cause by refrigeration failure.**



# Appendix

## Wiring Harness:

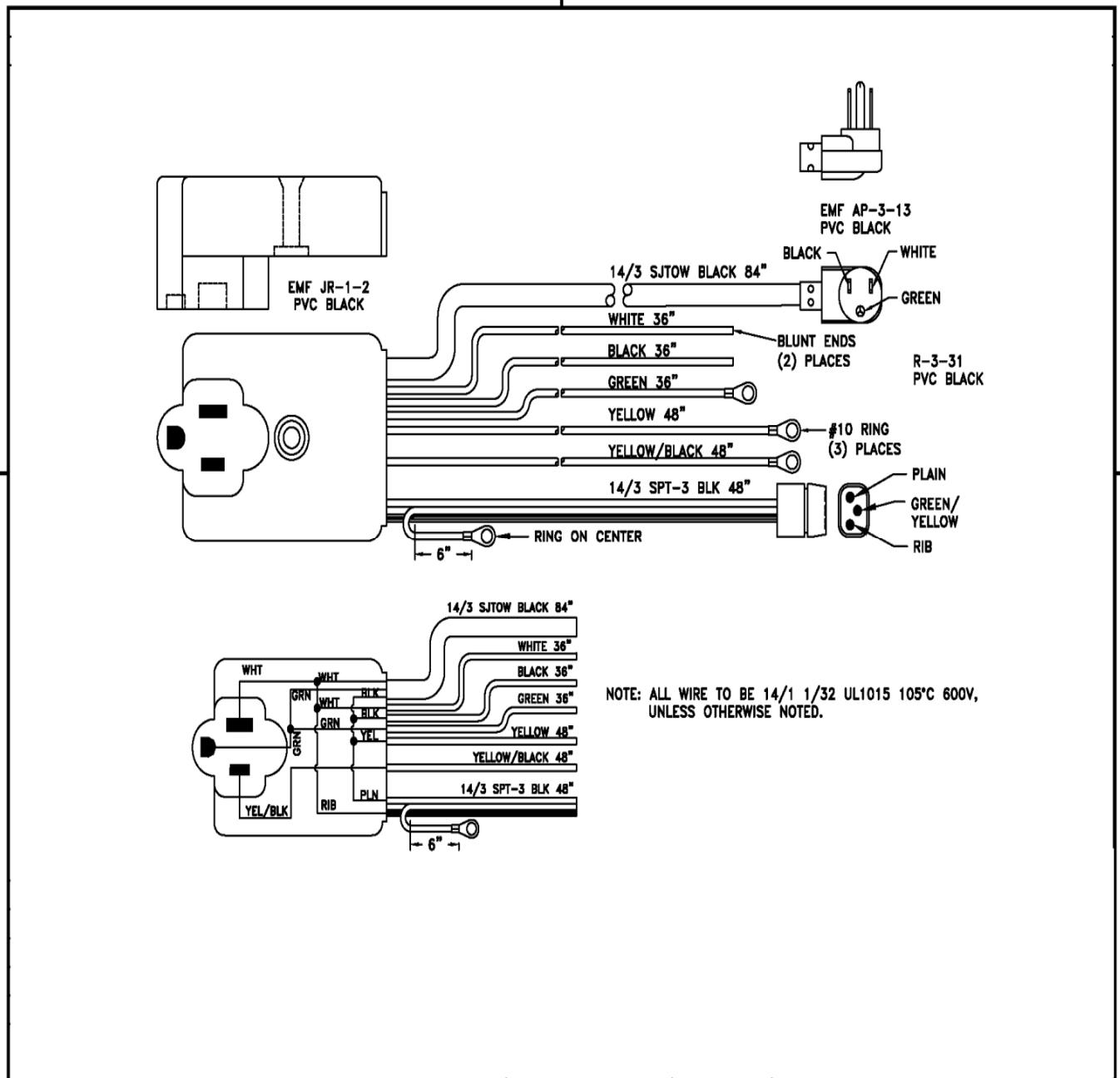

# Wiring Schematics:

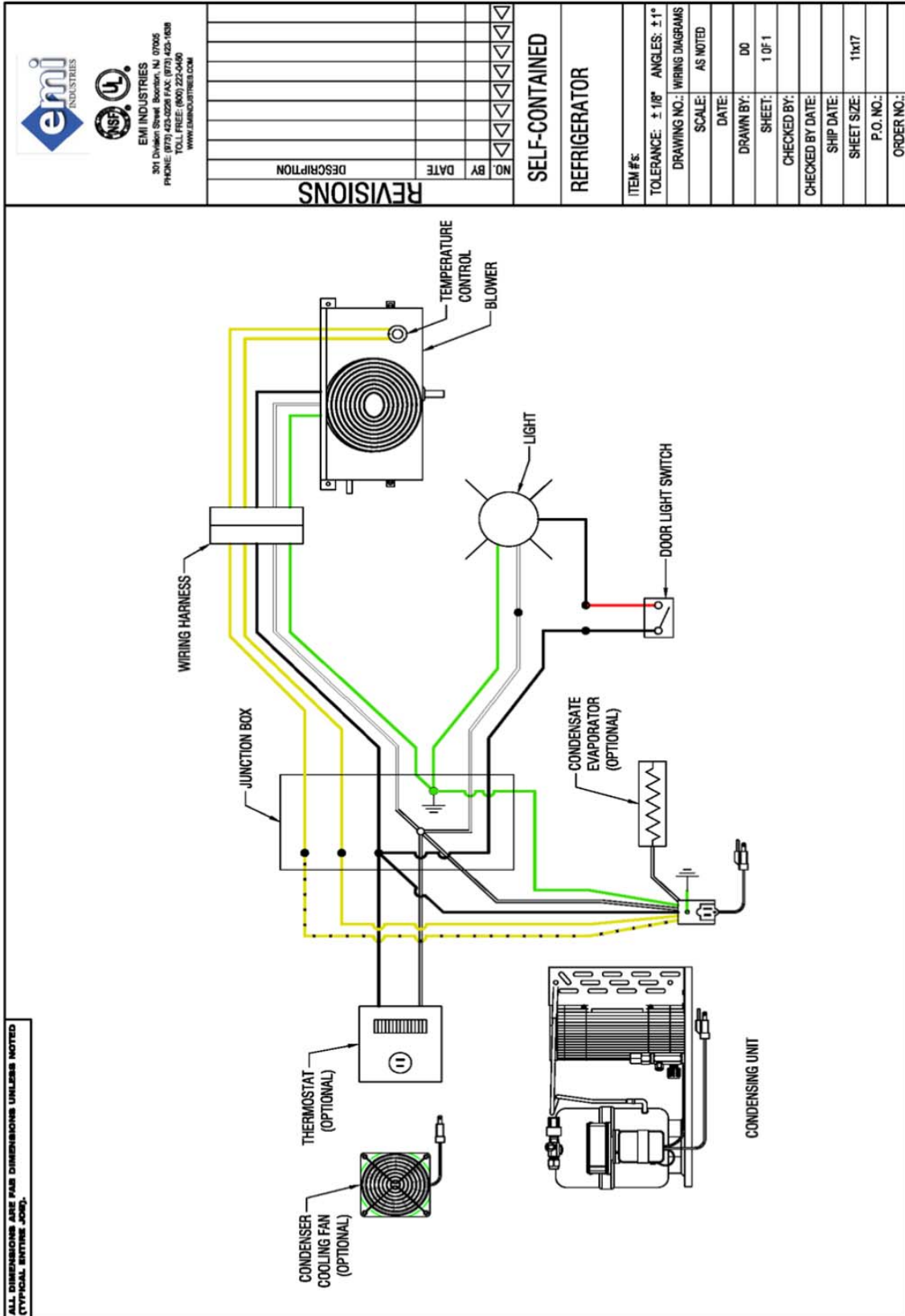

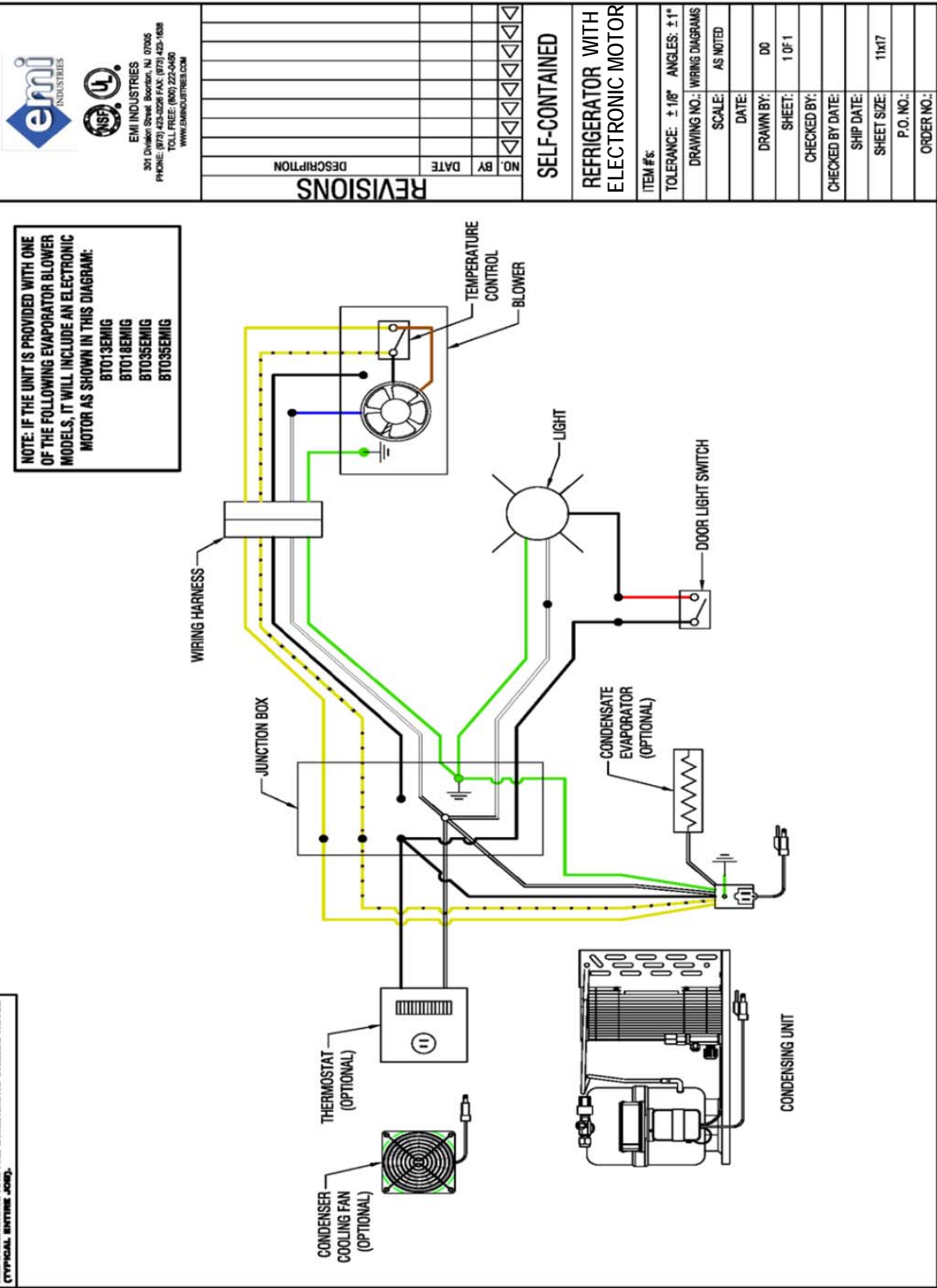

**emi**  
INDUSTRIES

EMIG INDUSTRIES  
 301 Division Street  
 Bonton, NJ 07005  
 PHONE: (973) 423-0226 FAX: (973) 423-1408  
 TOLL FREE: (800) 222-6466  
 WWW.EMIGCUSTOMER.COM

NO.	DATE	BY	DESCRIPTION

**SELF-CONTAINED REFRIGERATOR WITH ELECTRONIC MOTOR**

ITEM #s:

TOLERANCE: ± 1/8" ANGLES: ± 1°

DRAWING NO.: WIRING DIAGRAMS

SCALE: AS NOTED

DATE:

DRAWN BY: D0

SHEET: 1 OF 1

CHECKED BY:

CHECKED BY DATE:

SHIP DATE:

SHEET SIZE: 11x17

P.O. NO.:

ORDER NO.:

**Note:** When ordering replacement electronic motor, must specify blower model (# BTO XX EMIG).



EMI INDUSTRIES  
 301 Division Street, Boonton, NJ 07005  
 PHONE: (973) 425-0228 FAX: (973) 425-1838  
 TOLL FREE: (800) 222-0460  
 WWW.EMIINDUSTRIES.COM

### REVISIONS

NO.	BY	DATE	DESCRIPTION

### SELF-CONTAINED

### REFRIGERATOR W/ RAISED RAIL OR COLD PAN

ITEM #:	TOLERANCE: ± 1/8" ANGLES: ± 1°
DRAWING NO.: WIRING DIAGRAMS	SCALE: AS NOTED
DATE:	DRAWN BY: DD
SHEET: 1 OF 1	CHECKED BY:
SHIP DATE:	SHEET SIZE: 11x17
P.O. NO.:	ORDER NO.:

ALL DIMENSIONS ARE PER DIMENSIONS UNLESS NOTED  
 (TYPICAL ENTIRE JOB).

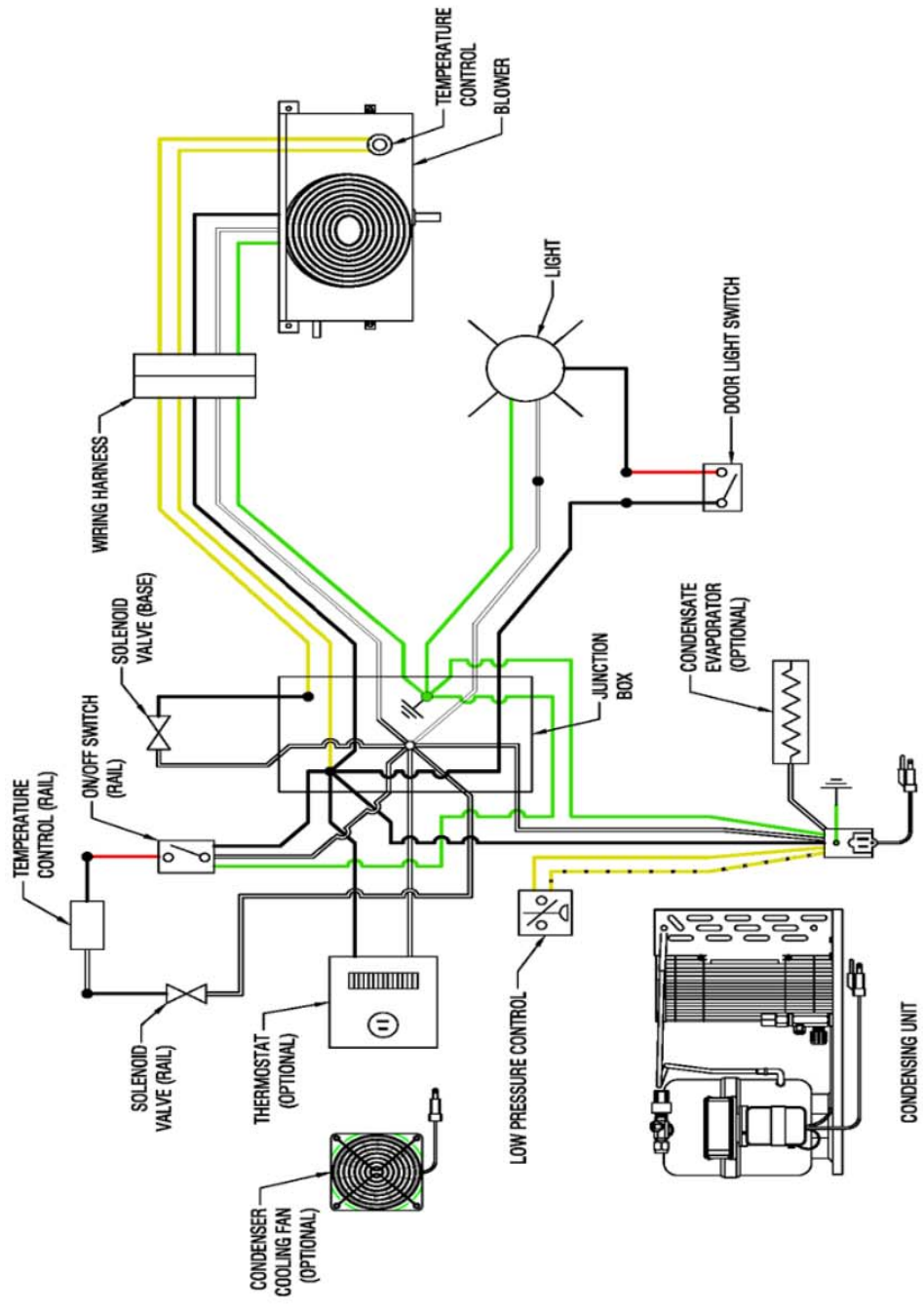



EMI INDUSTRIES  
301 Division Street, Boonton, NJ 07005  
PHONE: (973) 423-2208 FAX: (973) 423-1638  
TOLL FREE: (800) 222-6490  
WWW.EMINDUSTRIES.COM

NO.	BY	DATE	DESCRIPTION

**SELF-CONTAINED**

REFRIGERATOR W/  
RAISED RAIL / COLD  
PAN WITH  
ELECTRONIC  
MOTOR

SCALE:	AS NOTED
DATE:	
DRAWN BY:	DO
SHEET:	1 OF 1
CHECKED BY:	
CHECKED BY DATE:	
SHIP DATE:	
SHEET SIZE:	11x17
P.O. NO.:	
ORDER NO.:	

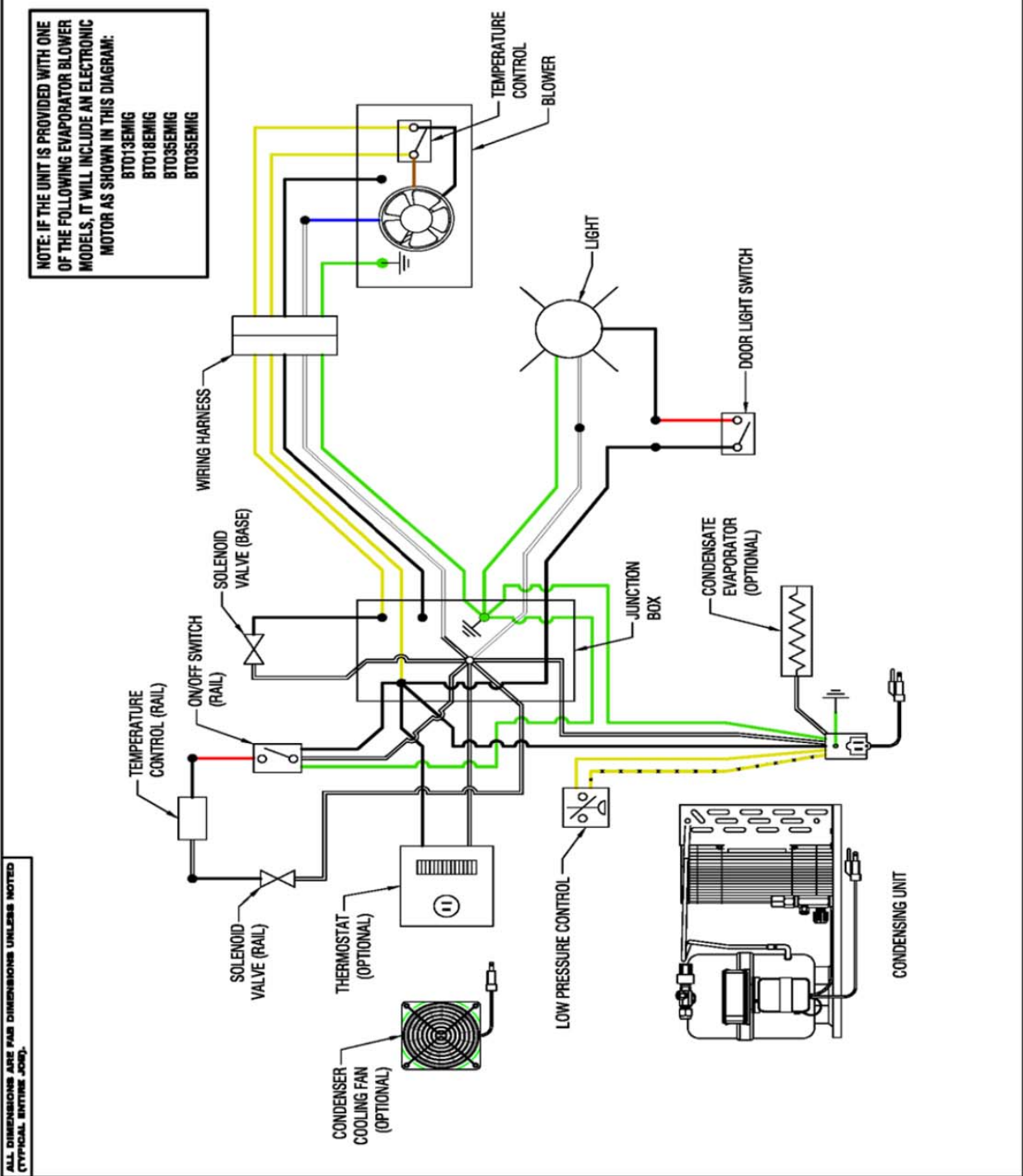

**Note:** When ordering replacement electronic motor, must specify blower model (# BTO XX EMIG).

ALL DIMENSIONS ARE FAB DIMENSIONS UNLESS NOTED  
(TYPICAL ENTIRE JOB).

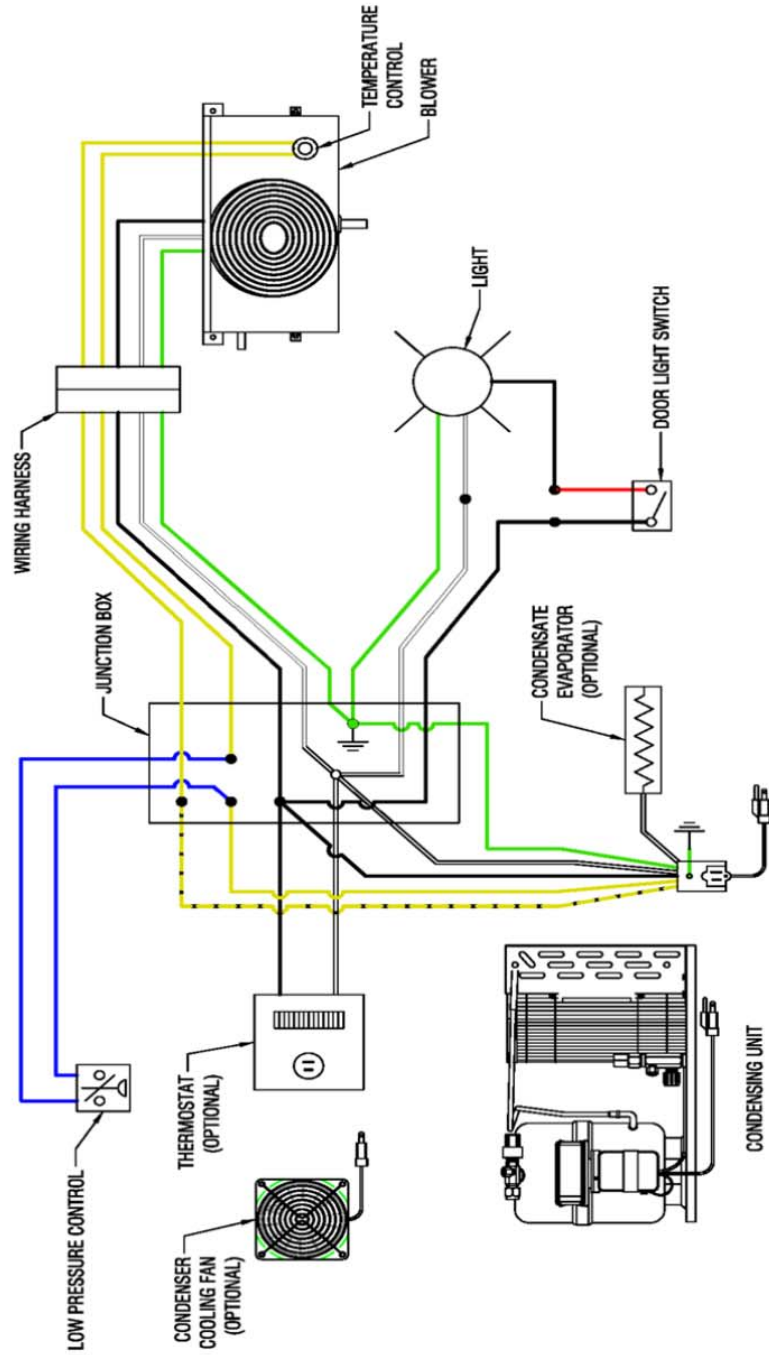

emi INDUSTRIES  
 NSF® U.  
 EMI INDUSTRIES  
 301 Division Street, Boonton, NJ 07005  
 PHONE: (973) 423-0226 FAX: (973) 423-1658  
 TOLL FREE: (800) 222-0460  
 WWW.EMINDUSTRIES.COM

NO.	BY	DATE	DESCRIPTION

SELF-CONTAINED  
 REFRIGERATOR W/  
 LOW PRESSURE SWITCH  
 ITEM #:  
 TOLERANCE: ± 1/8" ANGLES: ± 1°  
 DRAWING NO.: WIRING DIAGRAMS  
 SCALE: AS NOTED  
 DATE:  
 DRAWN BY: DO  
 SHEET: 1 OF 1  
 CHECKED BY:  
 CHECKED BY DATE:  
 SHIP DATE:  
 SHEET SIZE: 11x17  
 P.O. NO.:  
 ORDER NO.:



 EMI INDUSTRIES 301 Division Street, Boonton, NJ 07006 PHONE: (973) 423-0226 FAX: (973) 423-1638 TOLL FREE: (800) 222-6480 WWW.EMINDUSTRIES.COM	NO.	BY	DATE	DESCRIPTION
<b>REVISIONS</b>				
<b>SELF-CONTAINED REFRIGERATOR W/ LOW PRESSURE SWITCH</b>				
<b>W/ELECTRONIC MOTOR</b>				
SCALE:	AS NOTED			
DATE:				
DRAWN BY:	DO			
SHEET:	1 OF 1			
CHECKED BY:				
CHECKED BY DATE:				
SHIP DATE:				
SHEET SIZE:	11x17			
P.O. NO.:				
ORDER NO.:				

**NOTE: IF THE UNIT IS PROVIDED WITH ONE OF THE FOLLOWING EVAPORATOR BLOWER MODELS, IT WILL INCLUDE AN ELECTRONIC MOTOR AS SHOWN IN THIS DIAGRAM:**  
 BT013EMIG  
 BT018EMIG  
 BT035EMIG  
 BT035EMIG

ALL DIMENSIONS ARE FAR DIMENSIONS UNLESS NOTED (TYPICAL ENTIRE JOB).

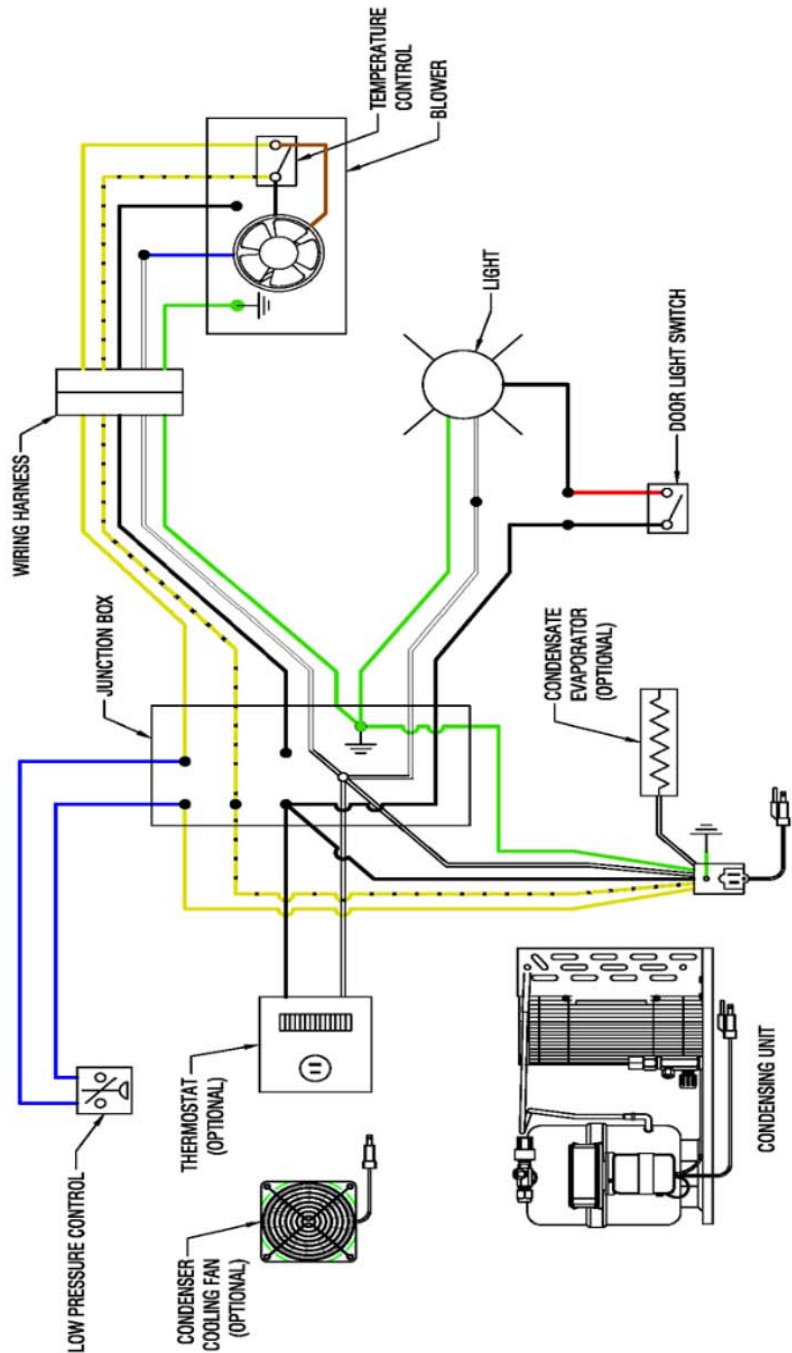

**Note:** When ordering replacement electronic motor, must specify blower model (# BTO XX EMIG).

ALL DIMENSIONS ARE FACE DIMENSIONS UNLESS NOTED (TYPICAL ENTIRE JOB).

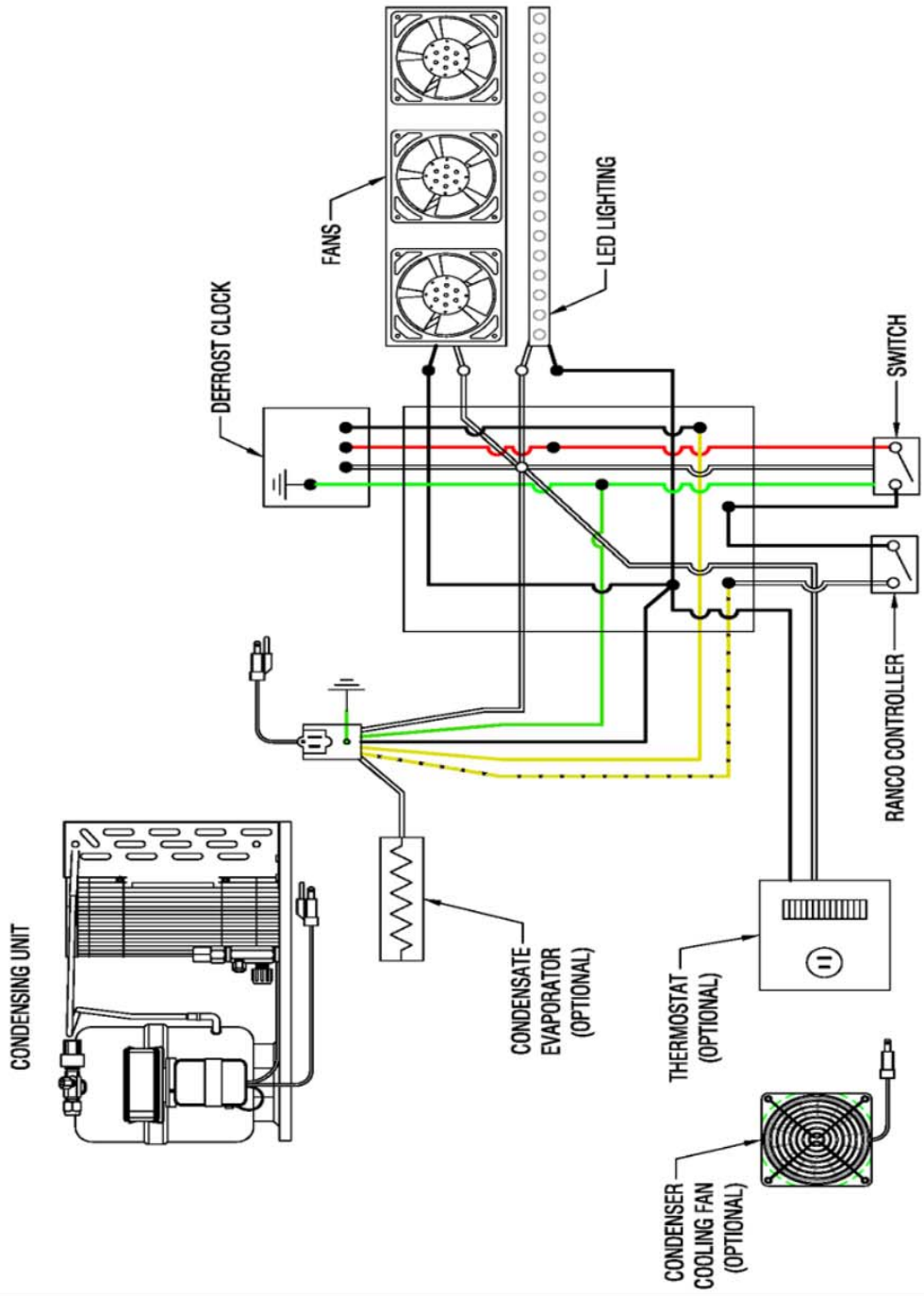

EMI INDUSTRIES  
301 Division Street, Bonton, N.J. 07005  
PHONE: (973) 423-0208 FAX: (973) 423-1638  
TOLL FREE: (800) 222-0490  
WWW.EMINDUSTRIES.COM

REVISIONS	
NO.	DATE

SELF-CONTAINED

GRAB & GO

ITEM #s:	
TOLERANCE: $\pm 1/8"$	ANGLES: $\pm 1^\circ$
DRAWING NO.:	WIRING DIAGRAMS
SCALE:	AS NOTED
DATE:	10/19/18
DRAWN BY:	DO
SHEET:	1 OF 1
CHECKED BY DATE:	
SHIP DATE:	
SHEET SIZE:	11x17
P.O. NO.:	
ORDER NO.:	



ALL DIMENSIONS ARE FOR DIMENSIONS UNLESS NOTED  
(TYPICAL BENTING JOB).

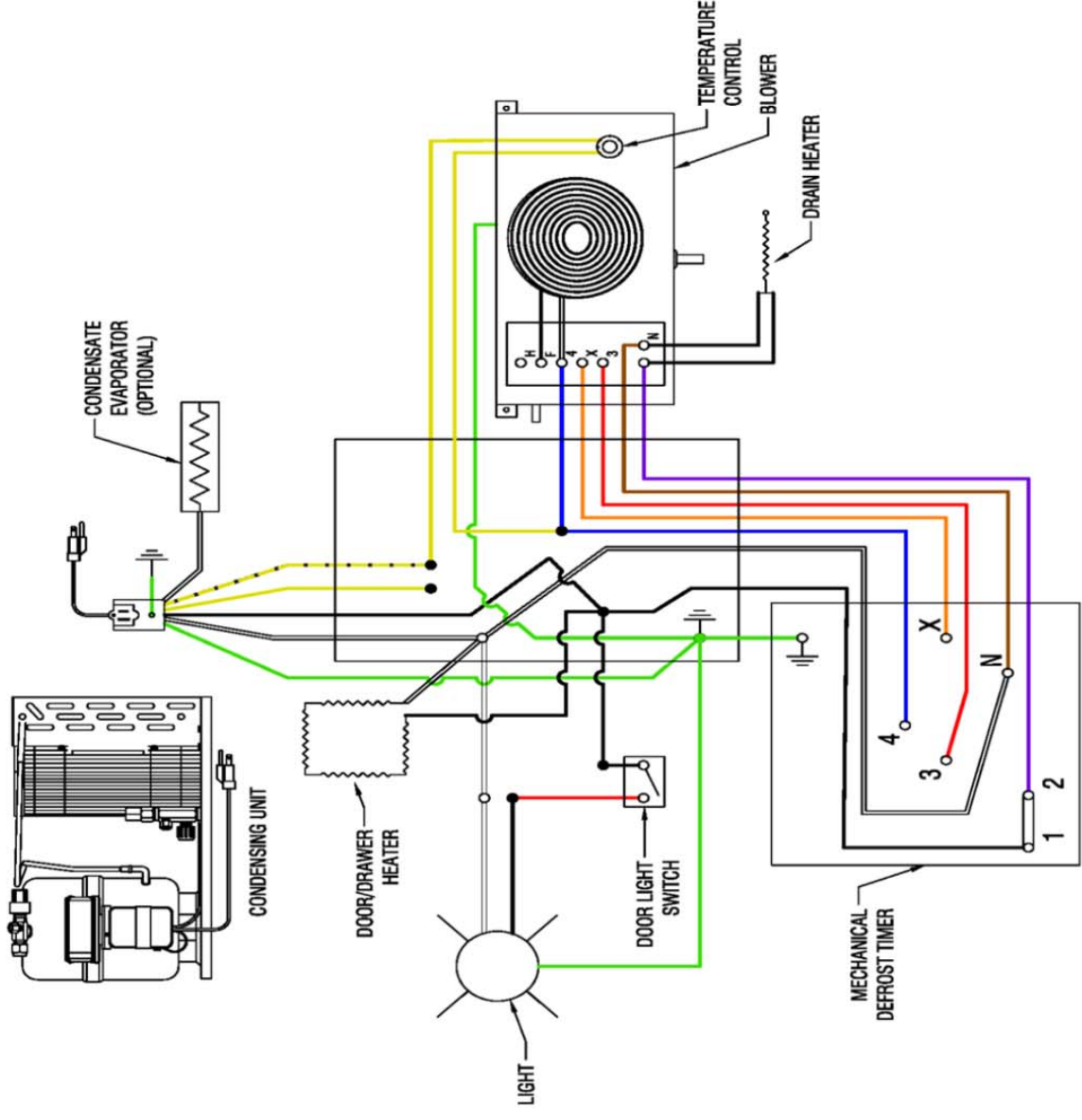

NO.	BY	DATE	DESCRIPTION

**REVISIONS**

**SELF-CONTAINED  
FREEZER**

ITEM #:	
TOLERANCE: ± 1/8" ANGLES: ± 1°	
DRAWING NO.: WIRING DIAGRAMS	
SCALE: AS NOTED	
DATE: 10/19/18	
DRAWN BY: DO	
SHEET: 1 OF 1	
CHECKED BY:	
CHECKED BY DATE:	
SHIP DATE:	
SHEET SIZE: 11x17	
P.O. NO.:	
ORDER NO.:	

 <b>emi INDUSTRIES</b> 301 Division Street, Becton, NJ 07005 PHONE: (873) 433-0228 FAX: (873) 433-1838 TOLL FREE: (800) 222-0450 WWW.EMIINDUSTRIES.COM		NO.	BY	DATE	DESCRIPTION
		REVISIONS	DESCRIPTION	DATE	BY
<b>SELF-CONTAINED</b>					
<b>REFRIGERATOR</b>					
<b>W/ FROST TOP</b>					
ITEM #s					
TOLERANCE: ± 1/8"	ANGLES: ± 1°				
DRAWING NO.:	WIRING DIAGRAMS				
SCALE:	AS NOTED				
DATE:	10/19/18				
DRAWN BY:	DO				
SHEET:	1 OF 1				
CHECKED BY:					
CHECKED BY DATE:					
SHIP DATE:					
SHEET SIZE:	11x17				
P.O. NO.:					
ORDER NO.:					

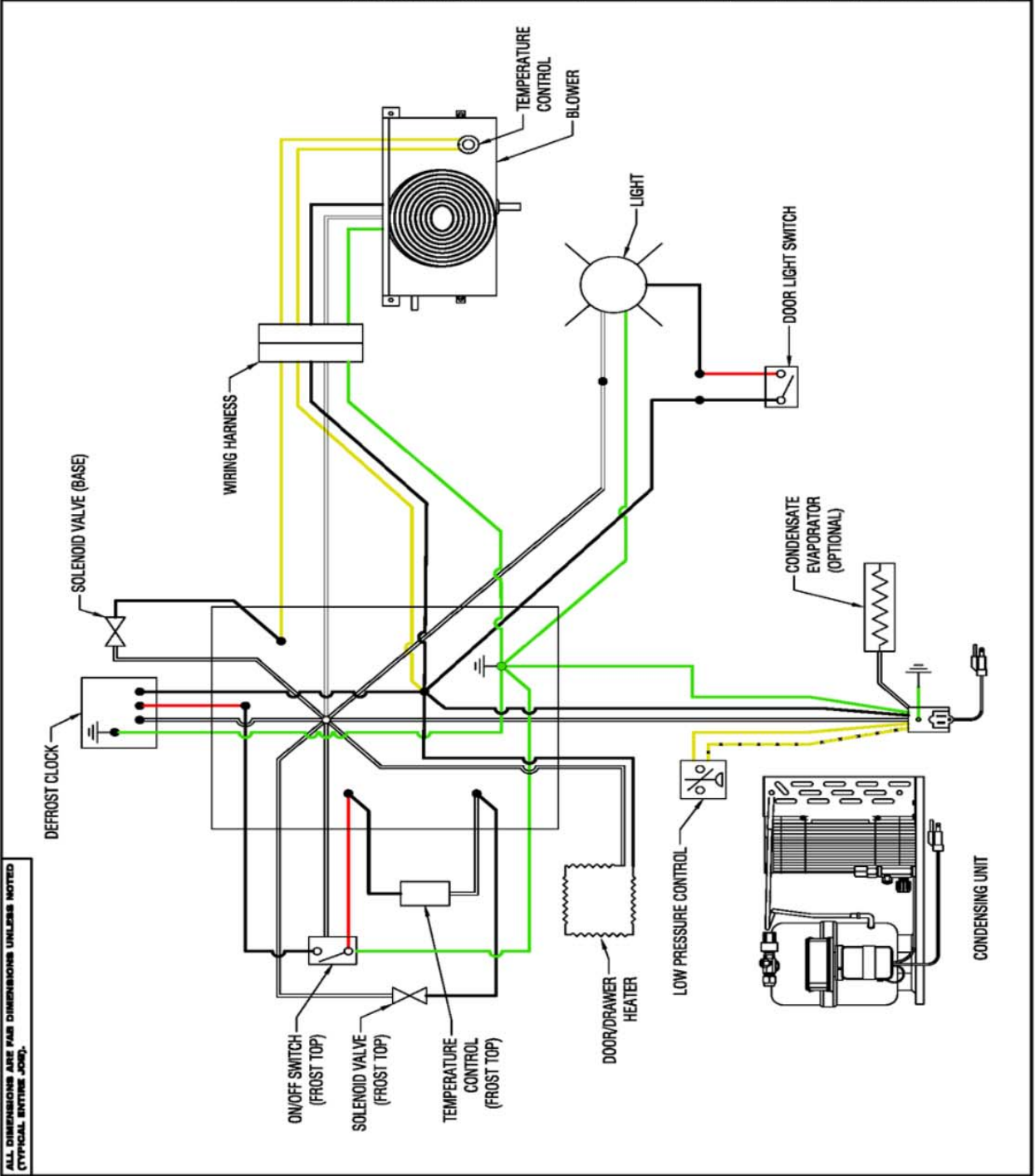

ALL DIMENSIONS ARE FOR DIMENSIONS UNLESS NOTED  
(TYPICAL ENTIRE JOB).

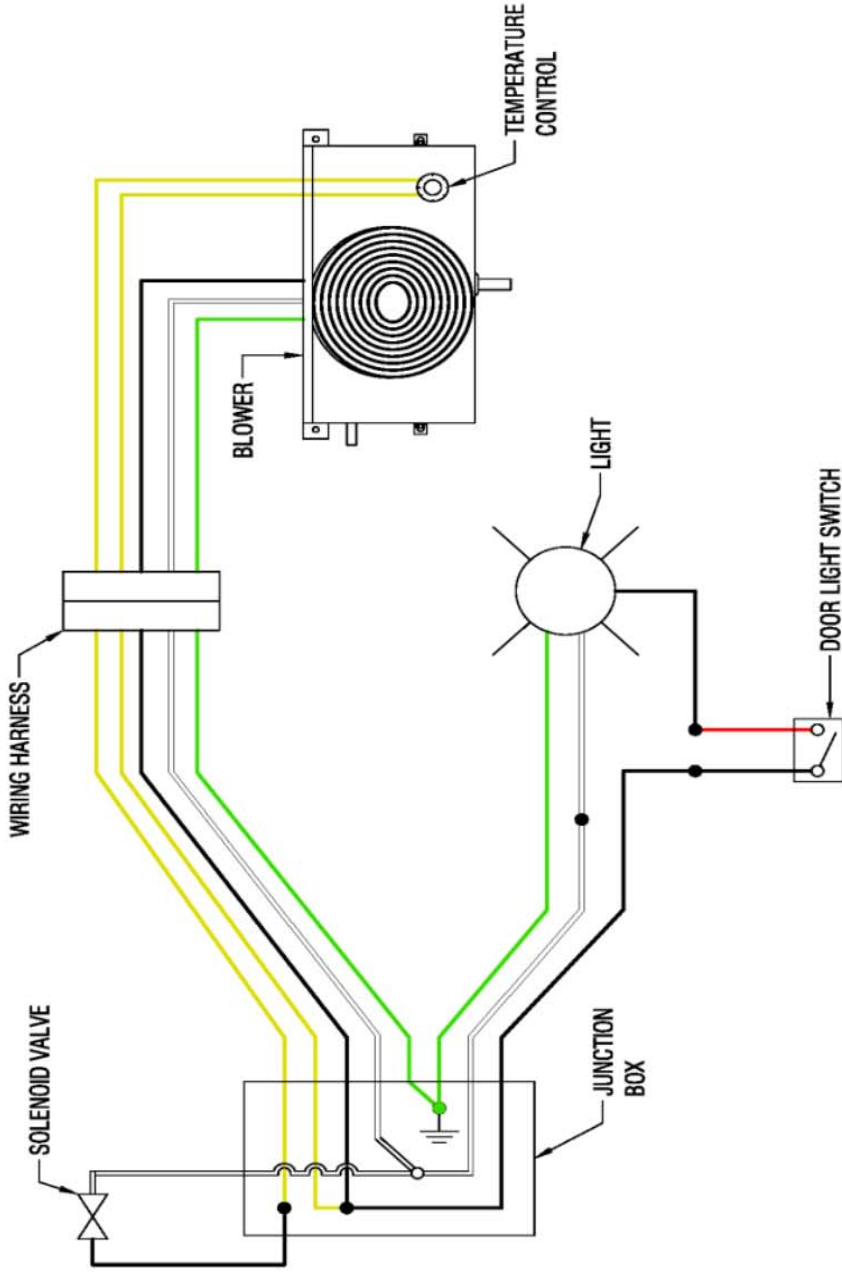

**emi INDUSTRIES**  
EM I INDUSTRIES  
301 Division Street, Boonton, NJ 07005  
PHONE: (973) 423-0228 FAX: (973) 423-1628  
TOLL FREE: (800) 222-5450  
WWW.EMINDUSTRIES.COM

**UL**  
**NSF**

NO.	BY	DATE	DESCRIPTION

REVISIONS

REMOTE REFRIGERATOR

ITEM #:	
TOLERANCE: ± 1/8° ANGLES: ± 1°	
DRAWING NO.: WIRING DIAGRAMS	
SCALE: AS NOTED	
DATE:	
DRAWN BY: DO	
SHEET: 1 OF 1	
CHECKED BY:	
SHIP DATE:	
SHEET SIZE: 11x17	
P.O. NO.:	
ORDER NO.:	

ALL DIMENSIONS ARE FAR DIMENSIONS UNLESS NOTED (TYPICAL ENTIRE JOB).

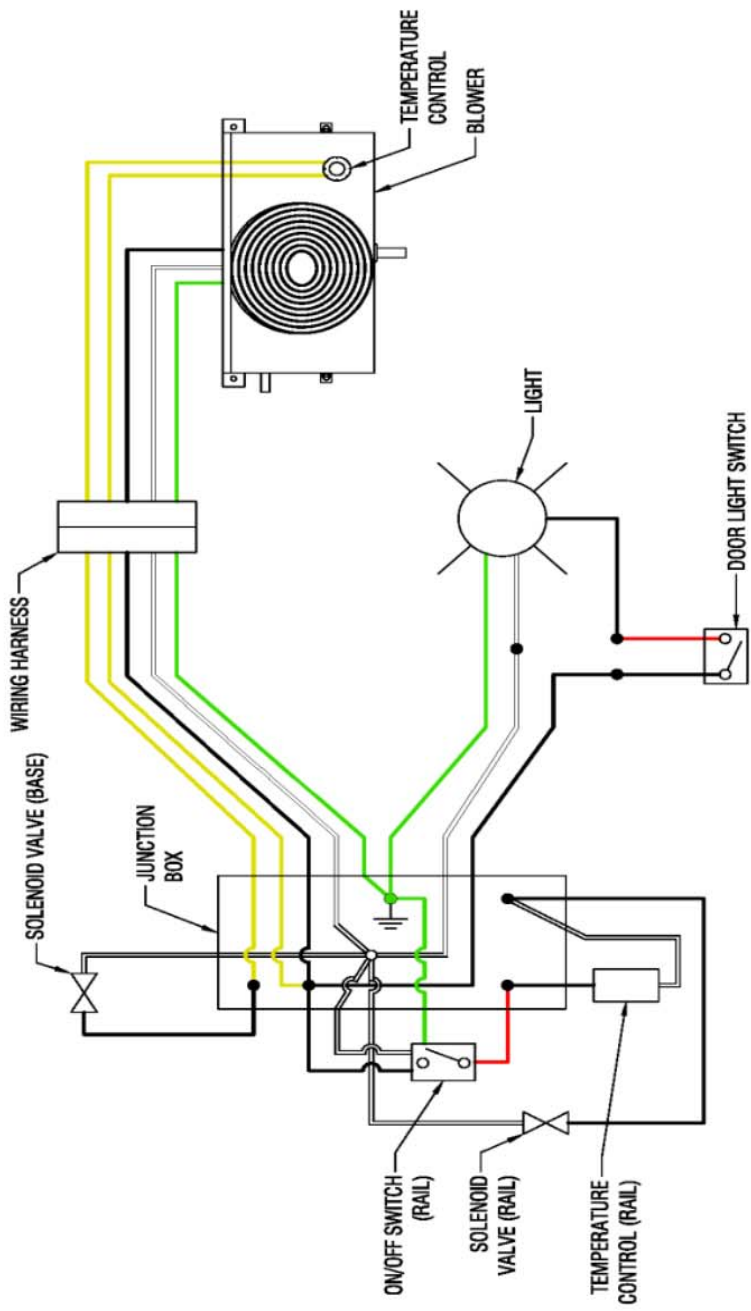

EMI INDUSTRIES  
 301 Division Street, Boonton, NJ 07006  
 PHONE: (973) 425-0226 FAX: (973) 425-1638  
 TOLL FREE: (800) 222-0460  
 WWW.EMICURTRES.COM

NO.	BY	DATE	DESCRIPTION

REVISIONS

REMOTE  
 REFRIGERATOR W/  
 RAISED RAIL OR COLD PAN

ITEM #:	
TOLERANCE: ± 1/8" ANGLES: ± 1°	
DRAWING NO.: WIRING DIAGRAMS	
SCALE: AS NOTED	
DATE:	
DRAWN BY: DO	
SHEET: 1 OF 1	
CHECKED BY:	
SHIP DATE:	
SHEET SIZE: 11x17	
P.O. NO.:	
ORDER NO.:	

ALL DIMENSIONS ARE FAR DIMENSIONS UNLESS NOTED  
(TYPICAL ENTIRE JOB).

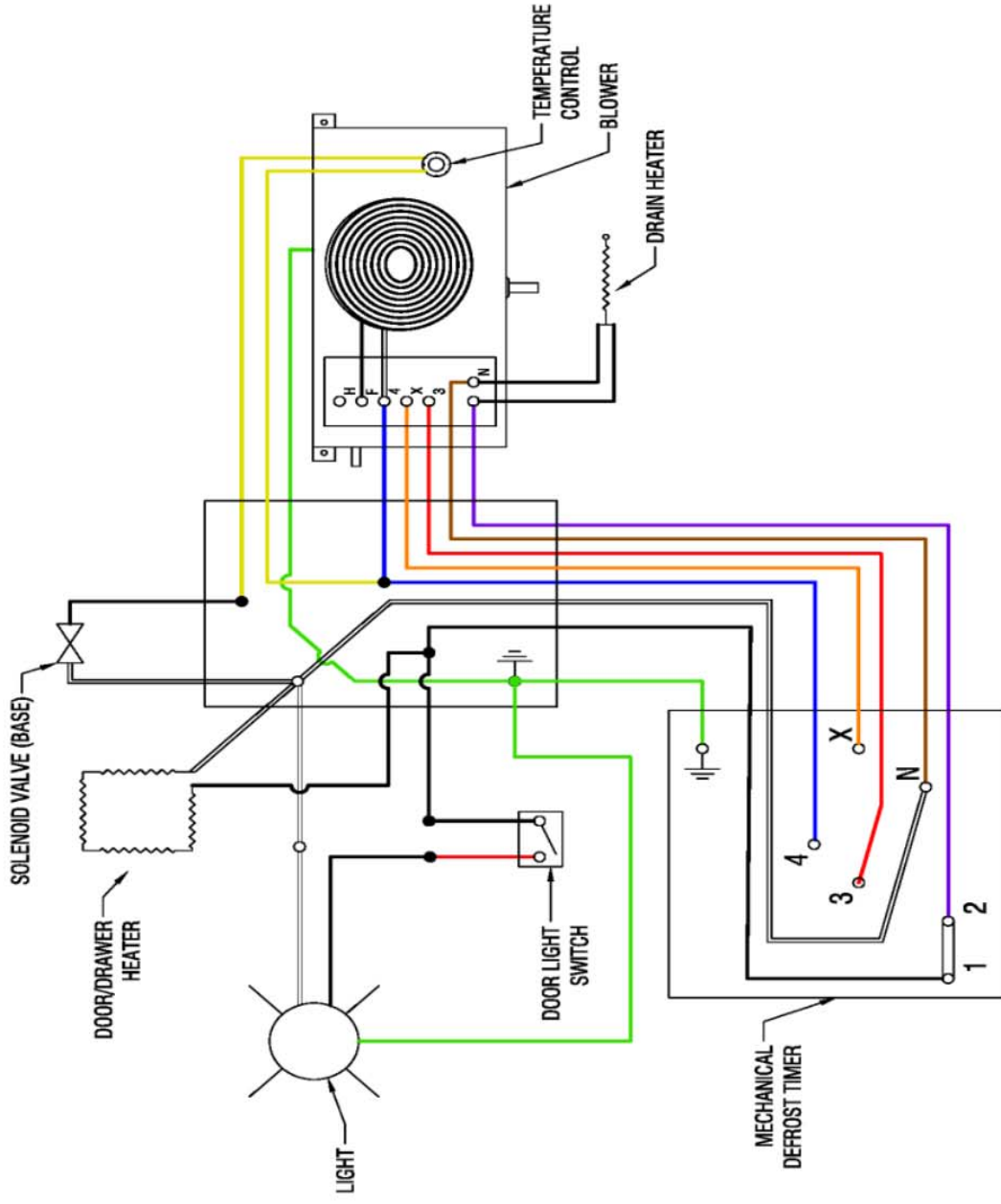

REVISIONS

NO.	BY	DATE	DESCRIPTION

REMOTE

FREEZER

**emi INDUSTRIES**  
 301 Division Street, Boonton, NJ 07005  
 PHONE: (973) 423-0226 FAX: (973) 423-1638  
 TOLL FREE: (800) 222-0490  
 WWW.EMIINDUSTRIES.COM

**UL**  
**NSF**

ITEM #:	
TOLERANCE: $\pm 1/8"$	ANGLES: $\pm 1^\circ$
DRAWING NO.:	WIRING DIAGRAMS
SCALE:	AS NOTED
DATE:	
DRAWN BY:	DO
SHEET:	1 OF 1
CHECKED BY:	
CHECKED BY DATE:	
SHIP DATE:	
SHEET SIZE:	11x17
P.O. NO.:	
ORDER NO.:	

ALL DIMENSIONS ARE PAR DIMENSIONS UNLESS NOTED  
(TYPICAL ENTIRE JOB).

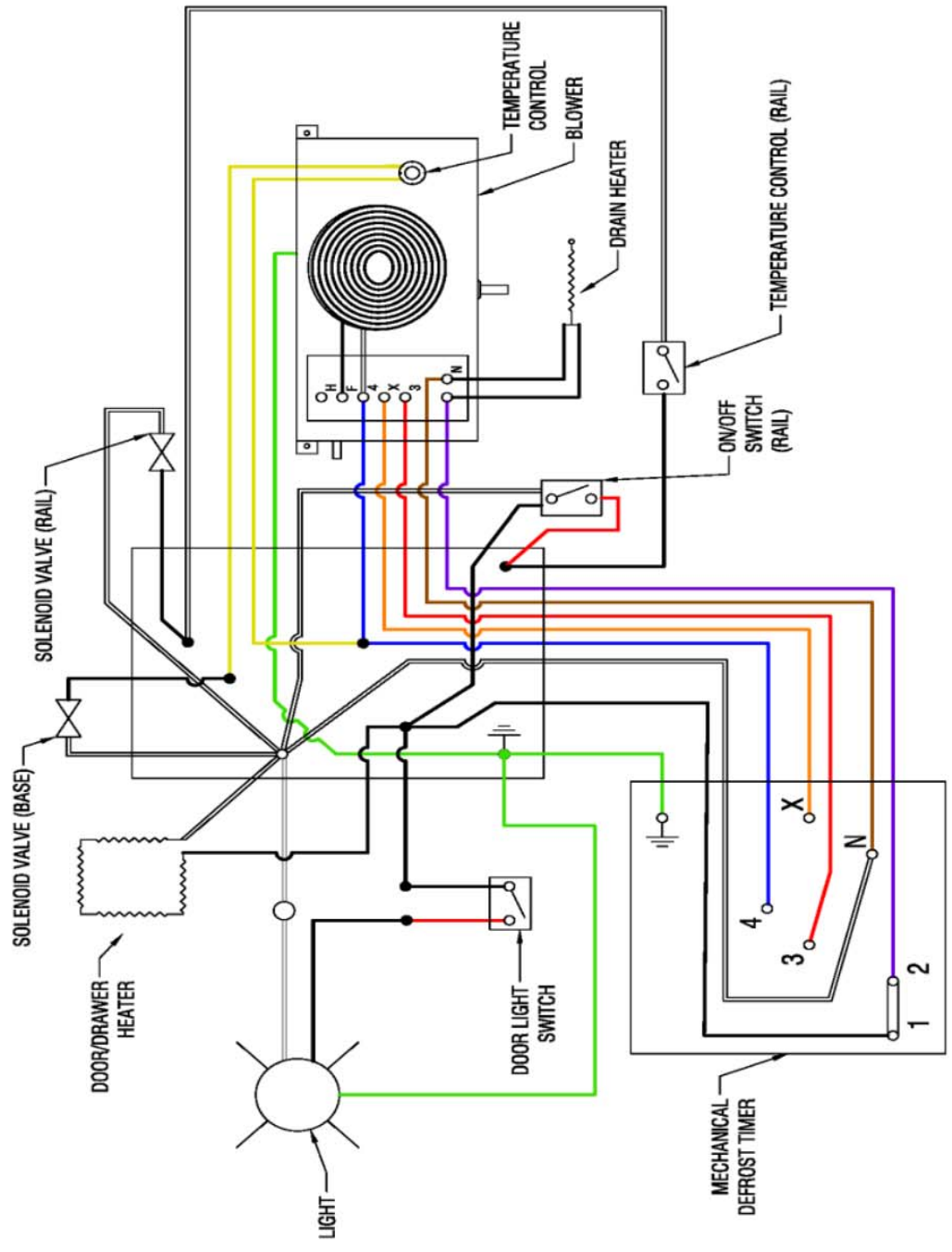

EMI INDUSTRIES  
301 Division Street, Boonton, NJ 07005  
PHONE: (973) 423-0226 FAX: (973) 423-1658  
TOLL FREE: (800) 222-0490  
WWW.EMINDUSTRIES.COM

REVISIONS

NO.	BY	DATE	DESCRIPTION

REMOTE

FREEZER W/ RAIL

ITEM #:	TOLERANCE: ± 1/8" ANGLES: ± 1°
DRAWING NO.:	WIRING DIAGRAMS
SCALE:	AS NOTED
DATE:	
DRAWN BY:	DO
SHEET:	1 OF 1
CHECKED BY:	
SHIP DATE:	
SHEET SIZE:	11x17
P.O. NO.:	
ORDER NO.:	



# Refrigeration Schematics:

ALL DIMENSIONS ARE FAB DIMENSIONS UNLESS NOTED (TYPICAL ENTIRE JOB).

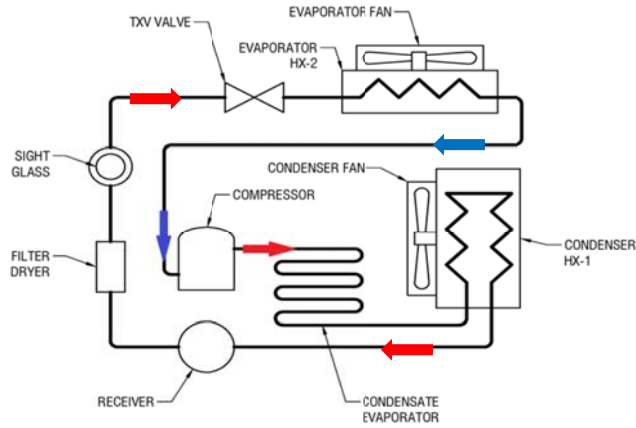

EMI INDUSTRIES  
301 Division Street Boonton, NJ 07005  
PHONE: (973) 423-0226 FAX: (973) 423-1638  
TOLL FREE: (800) 222-0450  
WWW.EMINDUSTRIES.COM

## REVISIONS

NO.	BY	DATE	DESCRIPTION

SELF CONTAINED

REFRIGERATOR

ITEM #s:	
TOLERANCE: $\pm 1/8"$	ANGLES: $\pm 1^\circ$
DRAWING NO.:	REFRIGERATOR
SCALE:	AS NOTED
DATE:	6/19/18
DRAWN BY:	DO
SHEET:	
CHECKED BY:	
CHECKED BY DATE:	
SHIP DATE:	
SHEET SIZE:	8.5 x 11
P.O. NO.:	
ORDER NO.:	

ALL DIMENSIONS ARE FAB DIMENSIONS UNLESS NOTED (TYPICAL ENTIRE JOB).

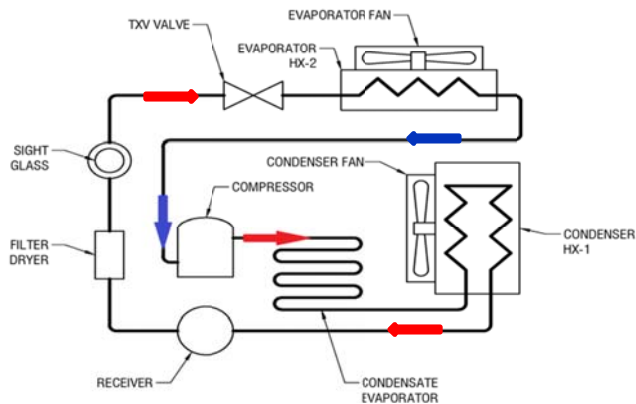

EMI INDUSTRIES  
301 Division Street Boonton, NJ 07005  
PHONE: (973) 423-0226 FAX: (973) 423-1638  
TOLL FREE: (800) 222-0450  
WWW.EMINDUSTRIES.COM

## REVISIONS

NO.	BY	DATE	DESCRIPTION

SELF CONTAINED

FREEZER

ITEM #s:	
TOLERANCE: $\pm 1/8"$	ANGLES: $\pm 1^\circ$
DRAWING NO.:	REFRIGERATOR
SCALE:	AS NOTED
DATE:	6/19/18
DRAWN BY:	DO
SHEET:	
CHECKED BY:	
CHECKED BY DATE:	
SHIP DATE:	
SHEET SIZE:	8.5 x 11
P.O. NO.:	
ORDER NO.:	

ALL DIMENSIONS ARE FAB DIMENSIONS UNLESS NOTED (TYPICAL ENTIRE JOB).

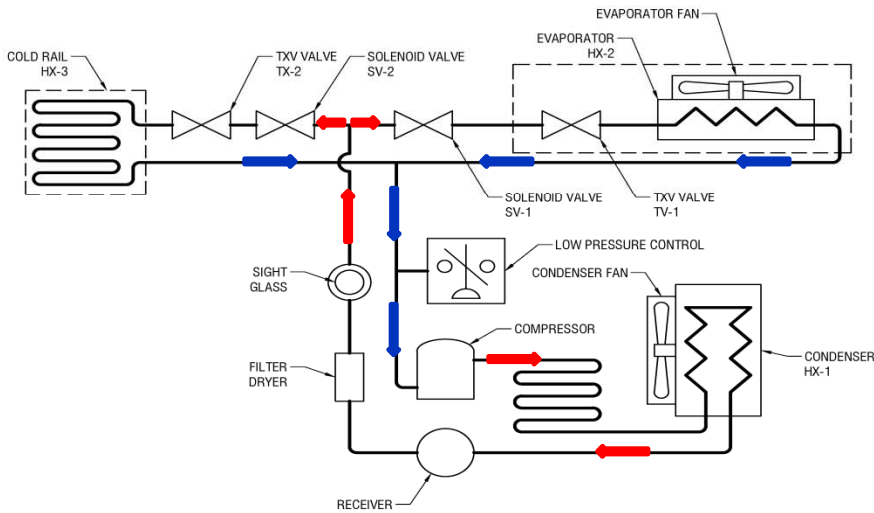

NSF UL  
 EMI INDUSTRIES  
 301 Division Street, Boonton, NJ 07005  
 PHONE: (973) 423-0226 FAX: (973) 423-1638  
 TOLL FREE: (800) 222-0450  
 WWW.EMIINDUSTRIES.COM

**REVISIONS**

NO.	BY	DATE	DESCRIPTION

**SELF CONTAINED**

**REFRIGERATOR  
 W/ RAIL OR COLD PAN**

ITEM #s:

TOLERANCE: ± 1/8"	ANGLES: ± 1°
DRAWING NO.:	REFRIGERATION
SCALE:	AS NOTED
DATE:	6/19/18
DRAWN BY:	DO
SHEET:	
CHECKED BY:	
CHECKED BY DATE:	
SHIP DATE:	
SHEET SIZE:	8.5 x 11
P.O. NO.:	
ORDER NO.:	

ALL DIMENSIONS ARE FAB DIMENSIONS UNLESS NOTED (TYPICAL ENTIRE JOB).

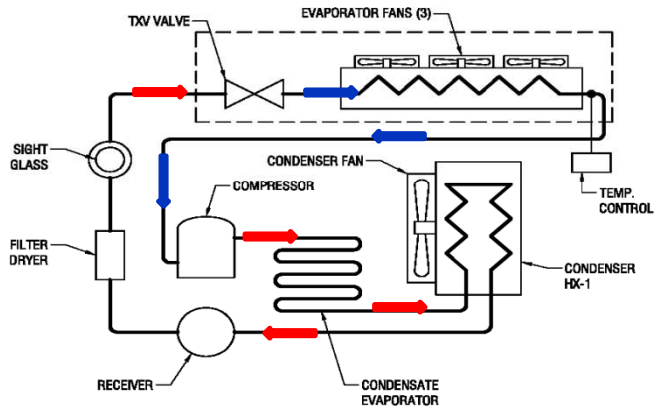

NSF UL  
 EMI INDUSTRIES  
 301 Division Street, Boonton, NJ 07005  
 PHONE: (973) 423-0226 FAX: (973) 423-1638  
 TOLL FREE: (800) 222-0450  
 WWW.EMIINDUSTRIES.COM

**REVISIONS**

NO.	BY	DATE	DESCRIPTION

**SELF CONTAINED**

**GRAB & GO**

ITEM #s:

TOLERANCE: ± 1/8"	ANGLES: ± 1°
DRAWING NO.:	REFRIGERATION
SCALE:	AS NOTED
DATE:	10/19/18
DRAWN BY:	DO
SHEET:	
CHECKED BY:	
CHECKED BY DATE:	
SHIP DATE:	
SHEET SIZE:	8.5 x 11
P.O. NO.:	
ORDER NO.:	



ALL DIMENSIONS ARE FAB DIMENSIONS UNLESS NOTED  
(TYPICAL ENTIRE JOB).

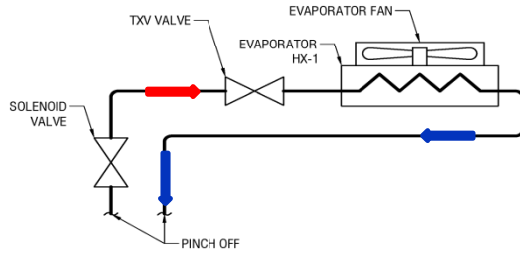

EMI INDUSTRIES  
301 Division Street Boonton, NJ 07005  
PHONE: (973) 423-0226 FAX: (973) 423-1638  
TOLL FREE: (800) 222-0450  
WWW.EMINDUSTRIES.COM

### REVISIONS

NO.	BY	DATE	DESCRIPTION

### REMOTE REFRIGERATOR

ITEM #s:	
TOLERANCE: $\pm 1/8"$	ANGLES: $\pm 1^\circ$
DRAWING NO.:	REFRIGERATION
SCALE:	AS NOTED
DATE:	6/19/18
DRAWN BY:	DO
SHEET:	
CHECKED BY:	
CHECKED BY DATE:	
SHIP DATE:	
SHEET SIZE:	8.5 x 11
P.O. NO.:	
ORDER NO.:	

ALL DIMENSIONS ARE FAB DIMENSIONS UNLESS NOTED  
(TYPICAL ENTIRE JOB).

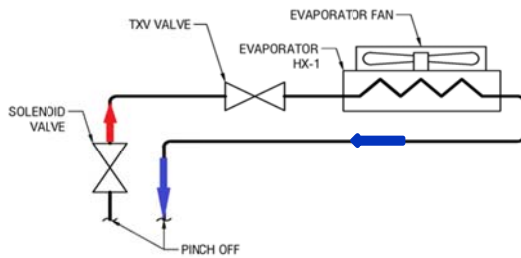

EMI INDUSTRIES  
301 Division Street Boonton, NJ 07005  
PHONE: (973) 423-0226 FAX: (973) 423-1538  
TOLL FREE: (800) 222-0450  
WWW.EMINDUSTRIES.COM

### REVISIONS

NO.	BY	DATE	DESCRIPTION

### REMOTE FREEZER

ITEM #s:	
TOLERANCE: $\pm 1/8"$	ANGLES: $\pm 1^\circ$
DRAWING NO.:	REFRIGERATION
SCALE:	AS NOTED
DATE:	6/19/18
DRAWN BY:	DO
SHEET:	
CHECKED BY:	
CHECKED BY DATE:	
SHIP DATE:	
SHEET SIZE:	8.5 x 11
P.O. NO.:	
ORDER NO.:	

ALL DIMENSIONS ARE FAB DIMENSIONS UNLESS NOTED  
(TYPICAL ENTIRE JOB).

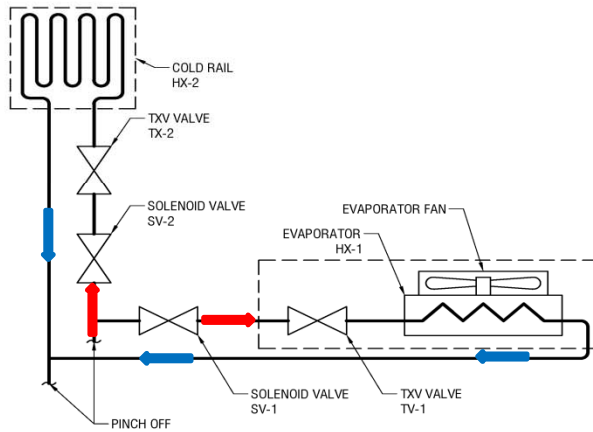

EMI INDUSTRIES  
301 Division Street, Bloomton, NJ 07005  
PHONE: (973) 423-0226 FAX: (973) 423-1638  
TOLL FREE: (800) 222-0450  
WWW.EMINDUSTRIES.COM

### REVISIONS

NO.	BY	DATE	DESCRIPTION

### REMOTE

### REFRIGERATOR W/ RAIL OR COLD PAN

ITEM #s:	
TOLERANCE: ± 1/8"	ANGLES: ± 1°
DRAWING NO.:	REFRIGERATION
SCALE:	AS NOTED
DATE:	6/19/18
DRAWN BY:	DO
SHEET:	
CHECKED BY:	
CHECKED BY DATE:	
SHIP DATE:	
SHEET SIZE:	8.5 x 11
P.O. NO.:	
ORDER NO.:	